

Ministry of Education and Science of Ukraine
Kharkiv National Automobile and Highway University
KhNAHU

S. S. Dushkin

METHODICAL GUIDELINES

for coursework
in the discipline

Water supply, sanitation and water quality improvement

For students majoring in
101 'Ecology'

Approved by the
university's methodological council
protocol No. dated 20

Kharkiv KhNAHU 2025

UDC 628.16

Reviewer

Dushkin S.S. Methodological guidelines for coursework in the discipline ‘Water supply, sanitation and water quality improvement’ / Dushkin Stanislav Sergeevich: Methodological guidelines. Kharkiv: KhNAHU – 30 p.

The methods for calculating water volumes to meet the needs of the city and firefighting, municipal needs and the needs of industrial enterprises are presented.

The methodological guidelines can also be used during diploma design.

UDC 628.16

BBK

Dushkin S.S., 2025

KhNAHU, 2025

CONTENTS

INTRODUCTION..... 4

1 Determination of estimated water consumption by individual consumer categories..... 4

1.1 Determination of water consumption for domestic and drinking needs of the city's population..... 4

1.2 Water consumption for municipal needs of the city..... 8

1.2.1 Water consumption for watering streets and squares..... 8

1.2.2 Water consumption for watering green spaces..... 8

1.3 Water consumption for industrial enterprises..... 8

1.3.1 Water consumption for domestic and drinking purposes of the enterprise..... 8

1.3.2 Water consumption for industrial purposes..... 9

1.3.3 Water consumption per shower at the enterprise..... 9

2 Tracing the water supply network..... 10

3 Hydraulic calculation of a ring water supply network..... 13

4 Construction of a piezometric pressure line..... 16

LIST OF RECOMMENDED SOURCES 19

Appendix A Tasks for calculation and graphical work 20

Appendix B Reference material 23

Appendix C Example of coursework calculation 34

INTRODUCTION

The construction of water supply networks for populated areas and industrial enterprises involves higher costs of materials and human resources, which in some cases account for up to 70–80% of the total costs of the entire water supply system. Therefore, the efficiency of capital investments in water supply construction largely depends on the calculation of water supply networks, the ultimate goal of which is to determine the optimal pipe diameters.

The methodological recommendations for performing computational and graphical work in the discipline 'Water Supply Systems and Structures' set tasks that determine water consumption for different categories of consumers and free heads in the water supply network.

The calculation and graphic work is performed in accordance with the curriculum. While performing the work, the student consolidates the knowledge gained in the discipline. The purpose of the work is to teach students to design and calculate a city water supply network. When performing the work, students use modern standards in accordance with the regulatory documents of Ukraine: DBN, DSTU, GOST, etc.

1 Determination of estimated water consumption by individual consumer categories

1.1 Determination of water consumption for domestic and drinking needs of the city's population

For example, let us consider the task with the following initial data:

- city plan with contour lines and main water supply networks (Fig. 1);
- population density – $P = 295$ people/ha;
- total built-up area – $F = 146.2$ ha;
- water consumption rate – $q = 350$ l/day·person;
- enterprise productivity – $EP = 120$ t/day;

- number of employees at the enterprise – $N = 5,000$ workers, including $N_{\max} = 2,600$ workers during the maximum shift;
- specific water consumption per unit of product or raw material – $q_p = 5 \text{ m}^3/\text{t}$.

When determining water consumption for a city's domestic and drinking needs, its amount must be calculated using Formula 1.1, where N is population (residents), F is city area (ha), and P is population density (people/ha).

The area of the city is determined after a thorough study of the city's layout: the results of calculations of the territory of residential quarters, which are preliminarily numbered and entered into Table 1.1.

Table 1.1 – Area of city districts

Quarter Num.	Area, ha	Quarter Num.	Area, ha
1	7,37	19	4,93
2	4,97	20	3,20
3	6,38	21	2,23
4	6,00	22	5,51
5	1,20	23	2,94
6	7,12	24	1,49
7	1,23	25	1,40
8	1,08	26	2,50
9	3,36	27	2,27
10	2,80	28	5,60
11	3,30	29	3,20
12	4,56	30	4,70
13	3,30	31	5,70
14	4,56	32	3,30
15	5,70	33	3,8
16	4,64	34	3,90
17	4,46	35	5,60
18	5,70	36	6,20
$F = \sum 146,2$			

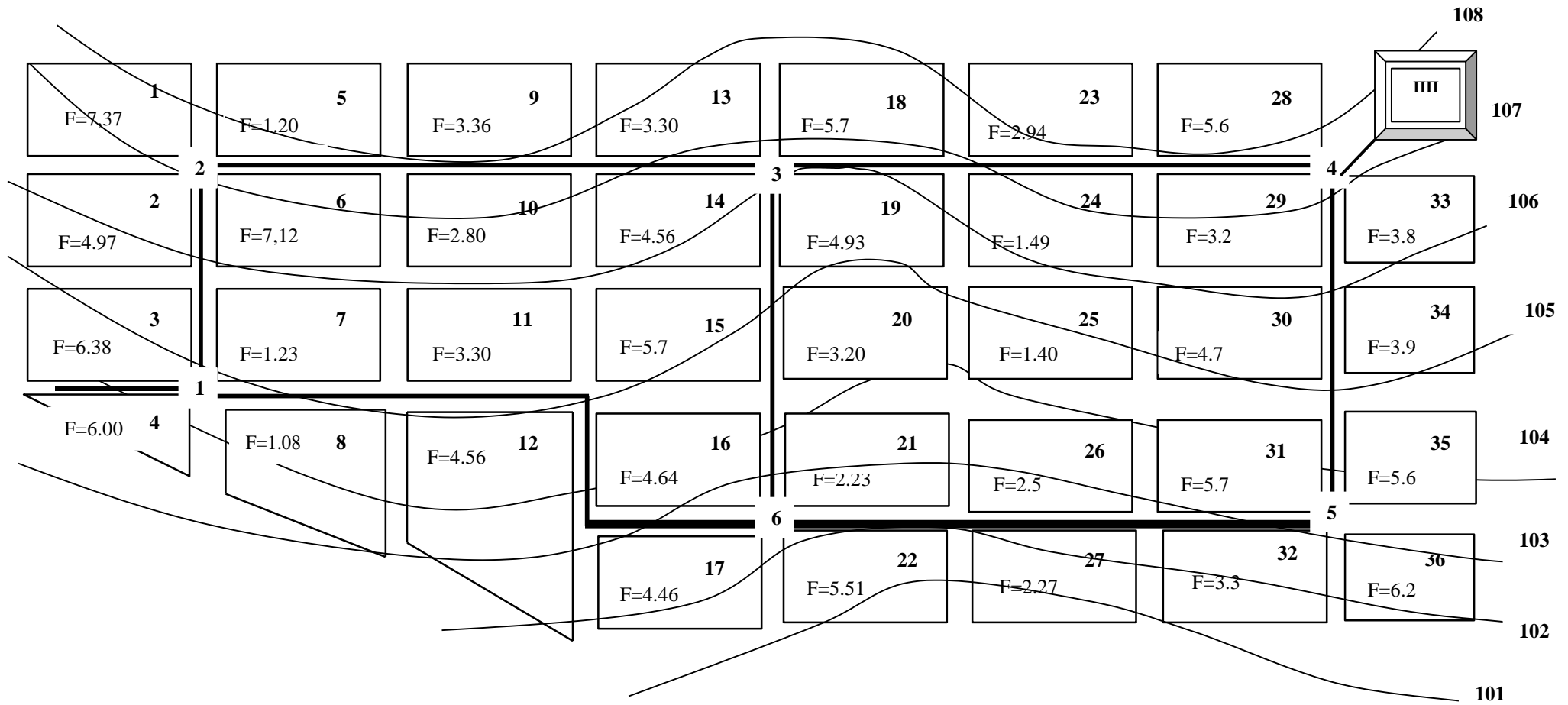

Figure 1 – City plan with contour lines showing the main water supply networks

Table 1.1 – Area of city districts

Quarter Num.	Area, ha	Quarter Num.	Area, ha
1	7,37	19	4,93
2	4,97	20	3,20
3	6,38	21	2,23
4	6,00	22	5,51
5	1,20	23	2,94
6	7,12	24	1,49
7	1,23	25	1,40
8	1,08	26	2,50
9	3,36	27	2,27
10	2,80	28	5,60
11	3,30	29	3,20
12	4,56	30	4,70
13	3,30	31	5,70
14	4,56	32	3,30
15	5,70	33	3,8
16	4,64	34	3,90
17	4,46	35	5,60
18	5,70	36	6,20
$F = \sum 146,2$			

In parallel with calculating the area of neighborhoods (Formula 1.2), the area of the city occupied by green spaces, streets, and squares is determined (Formula 1.3), assuming that green spaces cover 8% of the total city area and streets and squares account for 15% of the total area.

When determining water consumption for domestic and drinking purposes, the city's population is factored in based on its area and density. Thus, the maximum daily water consumption by the city's population is determined by Formula 1.4, where Q_{AD} is the average daily consumption, q_p is the water consumption norm per resident, and N is the number of residents in the city.

We determine the average hourly consumption using Formula 1.5, where Q_{AH} is the average hourly consumption.

The maximum hourly water consumption is calculated using formula (1.6), where the hourly irregularity coefficient K_h is defined by formula (1.7) with coefficients $a=1.2-1.4$ and β (Annex B, Table B.1) taken according to DBN V.2.5-74:2013.

The maximum instantaneous (second) water consumption is determined by formula (1.8).

1.2 Water consumption for municipal needs of the city

Water consumption for the city's municipal needs comprises Water consumption for municipal needs of the city (Section 1.2.1) and Water consumption for irrigation of green spaces (Section 1.2.2).

1.2.1 Water consumption for watering streets and squares

The maximum daily consumption is calculated using Formula 1.9, where F is the area being irrigated (m^2), q is the water consumption norm for irrigation (determined by the type of surface and irrigation method, see Appendix B, Table B.2), and 0.1 represents the percentage of irrigated areas as a fraction of the total green space area.

The average hourly consumption is calculated using Formula 1.5.

Maximum hourly consumption is calculated using Formula 1.6, where K_h – the coefficient of hourly irregularity of water consumption for irrigation; its value can be taken as 2.0 for large cities, and 4.0 for small and medium-sized cities.

Maximum water consumption is calculated using Formula 1.8.

1.2.2 Water consumption for watering green spaces

The calculation is performed similarly to the method described above. Formulas 1.9, 1.5, 1.6, and 1.8 are used in the calculation.

1.3 Water consumption for industrial enterprises

Water consumption for industrial enterprises consists of water consumption for domestic and communal needs, water consumption for showers, and water consumption for production needs.

1.3.1 Water consumption for domestic and drinking purposes of the enterprise

The machine-building plant employs 5,000 workers, including 2,600 workers in the maximum shift.

The plant operates in three shifts with the following distribution of workers per shift: 1st shift maximum – 2,600 workers – 52% of the total number of workers, then 24% of the total number of workers work in the 2nd and 3rd shifts, i.e. 1,200 workers each.

30% of the total number of workers work in cold workshops, and 70% in hot workshops, which is:

- cold workshop 30% – 1,500 workers;
- hot workshop 70% – 3,500 workers.

During the maximum shift, with 2,600 workers:

- cold workshop 30% – 780 workers;

- hot workshop 70% – 1,820 workers.

The average hourly consumption is calculated using formula 1.11, where 0.045 and 0.025 are the water consumption rates per worker in hot and cold workshops, respectively; $N_{h.w.}$ and $N_{c.w.}$ are the number of workers in hot and cold workshops at the enterprise, respectively.

The calculated maximum hourly (formula 1.12) and secondly (formula 1.8) consumption rates per day should be taken as the shift in which the largest number of workers are employed, i.e. in shift 1, where

- $n_{h.w.}$ and $n_{c.h.}$ are the number of workers employed at the enterprise in hot and cold workshops during the maximum shift, respectively;

- $K_{h.w.}$ and $K_{c.h.}$ are the hourly unevenness coefficients in hot and cold workshops, respectively, $K_{h.w.} = 2.5$, $K_{c.h.} = 3$;

- $T_{w.s.}$ is the duration of the work shift in hours, 8 hours.

1.3.2 Water consumption for industrial purposes

Water consumption for industrial needs of industrial enterprises is determined by the amount of output and specific consumption per unit of output.

The maximum daily water consumption of enterprises for production needs is determined by formula 1.13, where EP is the daily output of the enterprise; q_p is the average specific consumption per unit of output, m^3 .

In the absence of data on water consumption for production needs for individual shifts, water consumption is assumed to be equal throughout the entire period of the enterprise's operation.

The maximum hourly consumption is equal to (formula 1.14), where t is the duration of the enterprise's operation during the day, hours.

The maximum water consumption per second for production needs is calculated using formula 1.8.

1.3.3 Water consumption per shower at the enterprise

The number of employees using showers is determined for each enterprise in accordance with the sanitary standards for the design of industrial enterprises. At a machine-building plant, the number of employees using showers is 30% of the total number of employees, i.e. 1,500 workers, distributed among the workshops as follows: in cold workshops 5% – 250 workers, in hot workshops 25% – 1,250 workers.

During the maximum shift, with 2,600 employees, 30% use showers, i.e. 780 workers: in cold workshops 5% – 130 workers, in hot workshops 25% – 650 workers.

According to the norms, showers are used for 45 minutes after the end of each shift, and therefore the maximum hourly water consumption for showers is (formula

1.15), where the water consumption per shift is determined by formula 1.16 (0.06 and 0.04 – respectively, the consumption norms for one shower in hot and cold workshops).

The maximum water consumption per second is determined by formula 1.8).

The results of calculations of water consumption for industrial enterprises are summarised in Table 1.2.

Table 1.2 – Water consumption for industrial enterprises

Nature of water consumption	Q_{MD} , m ³ /day	Q_{AH} , m ³ /hour	Q_{MH} , m ³ /hour	Q_{MD} , l/s
Domestic and drinking water needs of the enterprise	–			
Water consumption per shower	–	–		
Water consumption for production needs		–		
TOTAL:	–	–		

It is advisable to compile a summary table of water consumption, where all consumption is entered by consumer category (Table 1.3).

Table 1.3 – Summary table of water consumption

Nature of water consumption	Q_{MD} , m ³ /day	Q_{AH} , m ³ /hour	Q_{MH} , m ³ /hour	Q_{MD} , l/s
Domestic and drinking water needs of the population				
Municipal needs of the city				
Water consumption at the enterprise	–	–		
Unaccounted consumption (5-10% of domestic and drinking water consumption)				
TOTAL:	–	–		

2 Tracing the water supply network

The water supply network is traced on the master plan. When designing (tracing) the network, the following provisions must be followed:

- to ensure reliability and uninterrupted supply to consumers, the network must be circular;
- each water supply network consists of main and distribution lines;
- main lines are designed in the direction of the main water flow;
- the main transit trunk lines are connected by bridges of trunk significance, resulting in a ring network;

- the length of the calculated sections of the trunk network rings is between 400 and 1000 m;
- it is not recommended to route main lines along the perimeter of buildings, as they will be insufficiently loaded.

The network nodes are numbered, the lengths of each section between the nodes are indicated, and the location of the concentrated water consumption – the enterprise – is determined. The diagram shows the water consumption and the direction of flow along the rings (Fig. 2).

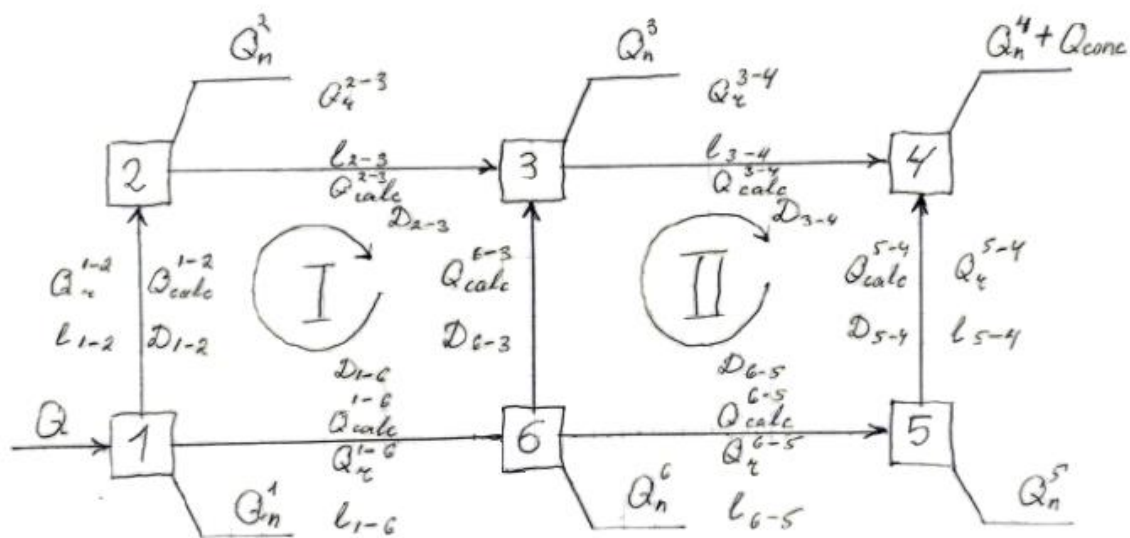

Figure 2 – Water supply network calculation diagram

The calculation assumes that water consumption from the network for domestic and drinking purposes is uniform along the length of the pipeline, with the exception of concentrated consumption (enterprise).

We determine the specific water consumption using formula 2.1, where Q – total flow rate per second, l/s; q_{cons} – water consumption at the enterprise, l/s; Σl – total length of the main network sections, m.

For each section of the main network, we determine the route costs using formula 2.2, where q_{sp} is the specific water consumption, l/s; l is the calculated length of the network section, m.

The sum of the flow rates of all calculated sections of the network must be equal to the total instantaneous water consumption of the city's population $\Sigma Q_r = Q$, which is a check of the correctness of the calculated flow rates.

According to the diagram (Fig. 1), we find Σl and ΣQ_r . We present the results in the form of a table.

Thus, the sum of the route costs of all calculated sections of the network must be equal to the total second water consumption for the city's population.

Based on the route cost values, the node costs at the calculated points of the network are determined. Therefore, the node-concentrated flow rate at each node of the network will be equal to half the sum of the flow rates of all sections of the network adjacent to this node.

We replace the calculated flow rates of individual sections with node flow rates using formula 2.3. That is, the node-centred flow in each node of the network is equal to the sum of the path flows of all network segments adjacent to that node.

The accuracy of the calculated node costs is verified using the following formula 2.4:

$$\Sigma Q_n = \Sigma Q_r = Q, \text{ l/s.} \quad (2.4)$$

The calculated route and node costs are entered into the calculation diagram (Fig. 2). The calculation diagram shows the diameters of the network sections and arrows indicating the direction of water flow in order to supply it by the shortest route to the most remote points of the network, and then the amount of water that each calculated section of the main network must pass is preliminarily estimated. The calculation should start from the end of the network to its beginning, maintaining a balance of water consumption at each node, i.e. the water entering and leaving the node $\Sigma Q = 0$.

When checking the network for water flow for firefighting, it is necessary to calculate the flow rates at the network nodes and then check the diameters of the network sections, which are already specified, based on the calculated flow rates, as they were determined earlier when drawing up the calculation scheme for maximum domestic and drinking water consumption.

Due to the increase in flow rates, the water velocity in some sections will be more 'economical', which is acceptable for firefighting. If the velocities exceed 2–2.5

m/s, it is necessary to increase the pipe diameters in these sections and recalculate the network for normal operation.

3 Hydraulic calculation of a ring water supply network

We write down the calculated route and node costs on the calculation diagram (Fig. 2). On the calculation diagram, we indicate the direction of water flow with arrows in order to supply it along the shortest distance to the most remote points of the network, and then we preliminarily estimate the amount of water that each calculated section of the main network must pass. The calculation section is taken to be the section of the main line between node points 1–2, 2–3, 3–4, etc. The distribution of design flows is carried out in accordance with the following rules:

- the distribution of design flows starts from the dictating point of the network (the most unfavourably located point of the network – in the example considered, node 4);
- the design flow rate is determined taking into account one of Kirchhoff's laws $\sum q = 0$, which characterises the water flow balance at the node: the algebraic sum of the flows at the node is zero, i.e. the sum of the flows entering the node is equal to the sum of the flows leaving the node.

Thus, the following must be applied to the design diagram:

- node flow rates Q_n ;
- lengths of design sections l ;
- concentrated flow rates of individual large consumers q_{conc} ;
- preliminary design flow rates Q_{calc} ;
- total flow rate supplied to the network Q .

The hydraulic calculation of a ring water supply network is based on two laws of water flow:

- first law: establishes the relationship between the flow entering and leaving a node. According to this law, the algebraic sum of the flows at each node is zero. $\sum q = 0$, where $\sum q$ - the sum of node and concentrated costs;
- second law: establishes the relationship between pressure losses in each closed

circuit. According to this law, the algebraic sum of pressure losses in each closed circuit of the network is equal to zero $\sum h = 0$.

When performing hydraulic calculations, it is permissible not to take into account head losses $\Delta h \leq \pm 0,5$.

Based on the estimated approximate costs for each section, using the tables by F. A. Shevelov or N. N. Abramov (Appendix B, Table B.3), the diameter of the network sections and the water flow velocity in them are selected. The specific resistance of the pipes is found in Table 3.1.

Table 3.1 – Specific resistance of pipes

D, mm	Specific resistance value A for q l/s	D, mm	Specific resistance value A for q l/s
50	$13\,360 \cdot 10^{-6}$	450	$0,119 \cdot 10^{-6}$
80	$1\,044 \cdot 10^{-6}$	500	$0,068 \cdot 10^{-6}$
100	$399 \cdot 10^{-6}$	600	$0,026 \cdot 10^{-6}$
125	$103,5 \cdot 10^{-6}$	700	$0,012 \cdot 10^{-6}$
150	$39,54 \cdot 10^{-6}$	800	$0,0\,057 \cdot 10^{-6}$
200	$8,608 \cdot 10^{-6}$	900	$0,0\,031 \cdot 10^{-6}$
250	$2,638 \cdot 10^{-6}$	1000	$0,0\,018 \cdot 10^{-6}$
300	$0,986 \cdot 10^{-6}$	1100	$0,001\,048 \cdot 10^{-6}$
350	$0,437 \cdot 10^{-6}$	1200	$0,00\,066 \cdot 10^{-6}$
400	$0,219 \cdot 10^{-6}$		

Given the length l , specific resistance A , and correction factor k for each section, we find the resistance of the calculated line

$$S = A \cdot k \cdot l. \quad (3.1)$$

The correction factor k for the A values for new cast iron pipes is selected according to Table 3.2 by interpolation.

Table 3.2 – Correction factor k for A values for new cast iron pipes

v , m/s	Values k	v , m/s	Values k
0,50	1,163	1,3	0,951
0,55	1,138	1,4	0,938
0,60	1,115	1,5	0,927
0,65	1,096	1,6	0,917
0,70	1,078	1,7	0,907
0,75	1,062	1,8	0,899

0,80	1,047	1,9	0,891
0,85	1,034	2,0	0,884
0,90	1,021	2,1	0,878
1,0	1,0	2,2	0,871
1,1	0,988	2,3	0,866
1,2	0,965	2,4	0,861

Pressure losses in each section are determined by the formula:

$$h = S \cdot Q^2 \quad (3.2)$$

The sign of head loss is determined by the following rule:

- if the direction of water flow in the section coincides with the clockwise direction, then head losses are taken with a '+' sign;
- if the direction of water flow in the section does not coincide with the clockwise direction, then head losses are taken with a '-' sign.

The total head loss in a closed circuit (ring) is obtained by algebraically summing all head losses in it. Usually, the preliminary distribution of the ring network's costs is incorrect, so in each ring of the network, the sum of head losses does not meet the specified accuracy $\Delta h = \pm 0,5$. It is necessary to redistribute the previously planned costs.

Many methods have been proposed for network balancing, of which the method developed by Prof. V. G. Lobachev has been widely used in practical calculations. According to this method, the balancing flow rate is calculated as follows:

$$\Delta q = -\frac{\pm \Delta h}{2\Sigma SQ}, \quad (3.3)$$

where Δh – ring imbalance; S – section resistance; Q – design flow rate of the section.

The network calculation using Professor V.G. Lobachev's method is summarized in the table below (Table 3.3).

Table 3.3 – Hydraulic calculation of the network using the method of V. G. Lobachev – H. Cross

№ rings	№ of the ring	Length of the blade l , m	Diameter D , mm	Resistivity $A \times 10^{-6}$	Preliminary cost allocation					
					q , l/s	v , m/s	k	$S=A \times k \times l \times 10^{-3}$	$h = \frac{S \times q^2}{1000}$	$S \times q \times 10^{-3}$
1	2	3	4	5	6	7	8	9	10	11

When balancing a ring in a water supply network, positive balancing flows should be added to positive line flows and subtracted from negative flows. Conversely, negative balancing flows should be subtracted from positive line flows and added to negative flows. Accordingly, the balancing flows are listed next to each section of the ring with a plus or minus sign. Corrections should be made to Table 3.4

Table 3.4 – Linking of the ring water supply network using the method of V. G. Lobachev – H. Cross

1 correction			
Δq , l/s	q , l/s	$h = \frac{S \times q^2}{1000}$	$S \times q \times 10^{-3}$
12	13	14	15

When determining the balancing flows for lines belonging to two adjacent rings, the balancing flows of the adjacent rings must be considered. Thus, if $\Delta h > 0$, then Δq should be directed counter-clockwise.

4 Construction of a piezometric pressure line

At any point in the external water supply network, the pressure must be sufficient for water to flow to the most remote water distribution device under its action.

The piezometric line is constructed based on the pressure at characteristic nodes, therefore the piezometric line represents the maximum line. When constructing a piezometric line, it is assumed that at the dictating point furthest from the sources, the pressure must not be lower than the standard.

The value of the required free pressure (H_f) in the water supply network of populated areas is calculated based on the following conditions: 10 m is taken for the first floor and 4 m for each subsequent floor:

$$H_f = 10 + 4(n - 1), \quad (4.1)$$

where n – number of floors.

We begin constructing the piezometric line by selecting a reference point on the master plan, whose free head is equal to the accepted value depending on the number of storeys in the building.

The piezometric mark for the first point (point 4) is found by adding the corresponding ground mark and free head at this point:

$$\Pi = z + H_f, \quad (4.2)$$

The piezometric elevation of each subsequent point is equal to the piezometric elevation of the previous point plus the head loss in the section between these nodal points:

$$\Pi = \Pi_{n-1} + h \quad (4.3)$$

Next, we perform calculations related to the construction of the piezometric pressure line, which we ultimately summarise in Table 4.1 and construct the piezometric pressure lines (Fig. 3).

Table 4.1 – Calculation data for constructing the piezometric pressure line

Node No.	Section No.	Section length, m.	Head loss, m	Free head, m	Ground surface elevation, m	Piezometric elevations, m
4	–	–	–	30	107,5	137,5
3	3-4	845	11,09	42,59	106,0	148,59
2	2-3	995	7,29	48,88	107,0	155,88
1	1-2	800	6,10	57,48	104,5	161,98

Figure 3 – Piezometric pressure line

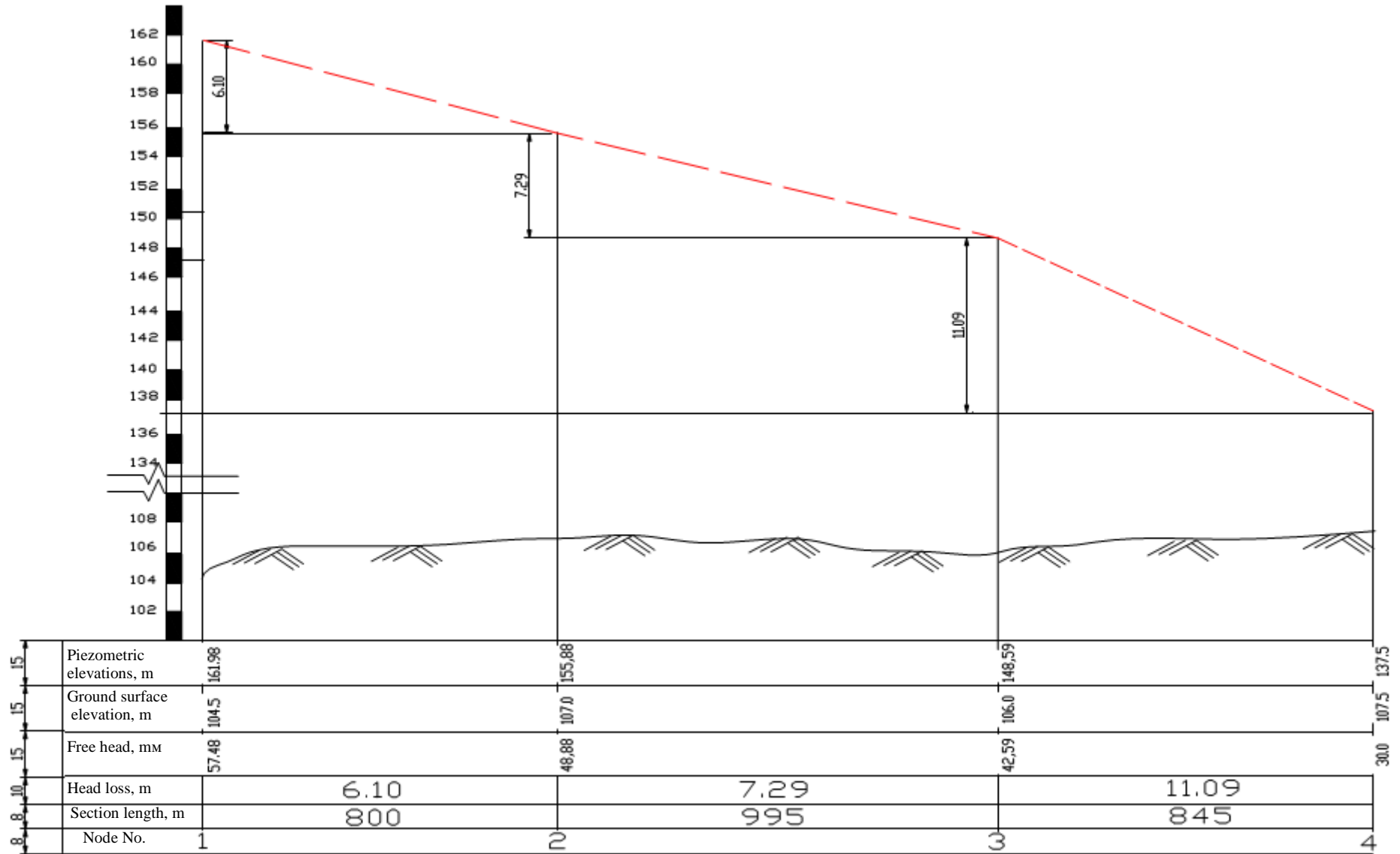

LIST OF RECOMMENDED SOURCES

1. Dystantsiinyi kurs «Vodopostachannia, vodovidvedennia i pokrashchennia yakosti vody» [Elektronnyi resurs]. – <https://dl2022.khadi-kh.com/course/view.php?id=6362>
2. Dushkin S.S. Kurs leksii z dystsypliny «Vodopostachannia, vodovidvedennia i pokrashchennia yakosti vody» / Dushkin Stanislav Serhiovych: Kurs leksii. Kharkiv: KhNADU – 149 s.
3. Metodychni vказivky z dystsypliny «Vodopostachannia, vodovidvedennia i pokrashchennia yakosti vody» / ukladach Dushkin Stanislav Serhiovych: Metodychni vказivky. Kharkiv: KhNADU – 67 s.
4. DBN V.2.5-74:2013 Vodopostachannia. Zovnishni merezhi ta sporudy. Osnovni polozhennia proektuvannia. – Kyiv : Ministerstvo rehionalnoho rozvytku, budivnytstva ta zhytlovo-komunalnoho hospodarstva Ukrainy, 2013. – 283 s.
5. Shadura V. O., Kravchenko N. V. Vodopostachannia ta vodovidvedennia : Navchalnyi posibnyk. Vyd. 2-he, pererob. i dopov. [Elektronne vydannia]. – Rivne: NUVHP, 2023. – 385 s.
6. Dobrovol'ska O.H. Vodoprovodni merezhi: Navchalno-metodychnyi posibnyk. Zaporizhzhia: ZNU, 2022. 221 s.

Appendix A Tasks for calculation and graphical work

Var	Water consumption rate l/day	Specific water consumption, m ³ /t	Enterprise productivity, t	Number of employees, persons	Number of employees in max. shift, work	Length, m								Number of floors		
						No. ring	Plot number				No. ring	Plot number				
							1-2	2-3	3-6	1-6		3-4	4-5		5-6	3-6
1	450	5,5	226	5200	3800	I	800	995	1200	1115	II	845	1050	860	1200	6
2	400	5,7	325	6500	4200		750	990	1100	1110		800	1000	850	1100	7
3	350	4,8	123	4250	3500		820	950	1150	1100		850	1100	800	1150	4
4	300	2,3	546	7500	5900		815	970	1300	1118		855	1025	810	1300	5
5	320	8,0	123	5100	3500		810	985	1350	1150		825	1020	825	1350	8
6	315	5,7	265	6300	4200		760	980	1220	1250		830	1100	795	1220	9
7	250	4,5	426	5300	2800		780	992	1200	1100		840	1000	815	1200	7
8	325	5,2	362	4500	2790		805	975	1250	1130		835	1030	805	1250	6
9	400	3,0	450	6500	4100		790	920	1240	1110		808	1010	845	1240	5
10	420	4,7	120	2600	1750		770	960	1225	1150		822	1110	820	1125	7
11	415	8,0	235	7800	5800		775	950	1105	1125		845	1015	835	1105	4
12	425	7,8	532	6900	3600		810	930	1245	1111		810	1040	810	1245	8
13	430	5,4	632	5890	3250		850	920	1205	1115		855	1035	850	1205	7
14	340	5,5	420	4560	2360		760	925	1235	1108		815	1020	840	1235	9
15	360	6,2	520	3590	1980		815	965	1105	1140		820	1045	870	1105	6
16	380	4,7	450	4780	2560		810	995	1220	1100		810	1090	825	1220	5
17	370	4,6	625	6300	3800		765	960	1240	1120		850	1100	830	1240	4
18	280	9,0	540	9630	5625		790	935	1200	1130		840	1050	850	1200	8
19	360	5,6	460	8750	4890		830	965	1210	1150		855	1110	840	1210	7
20	350	7,8	480	4500	3100		860	980	1300	1005		835	1095	870	1300	9
21	410	5,6	475	6500	2780		805	960	1270	1105		845	1035	880	1270	8
22	425	4,5	520	4250	2600		820	955	1310	1000		860	1070	865	1310	5
23	325	4,9	350	5600	3210		835	975	1300	1190		650	1055	840	1300	7
24	415	3,6	480	8900	4850		795	950	1320	1180		820	1060	855	1320	6
25	475	8,7	250	7850	3870		800	985	1305	1200		835	1000	860	1305	9

Appendix A

No	Area of quarters, hectares																								
	Variant No.																								
	1	2	3	4	5	6	7	8	9	10	11	12	13	14	15	16	17	18	19	20	21	22	23	24	25
1	1,08	6,68	5,13	7,38	6,95	5,99	6,03	6,95	7,12	7,23	8,21	6,23	5,92	6,03	6,05	6,15	6,23	6,91	7,02	7,15	8,02	7,12	8,31	6,12	7,21
2	3,36	3,78	4,92	3,81	4,71	4,83	5,21	4,02	5,11	3,87	4,85	4,18	4,22	3,99	5,13	3,53	4,92	5,05	4,33	5,03	5,17	4,95	4,71	4,21	4,81
3	2,80	5,94	3,97	6,12	6,02	6,15	5,98	4,87	6,15	3,45	6,25	4,96	6,18	5,96	7,15	7,22	6,21	7,93	5,35	8,01	6,33	6,20	5,33	5,87	6,18
4	3,30	5,53	4,28	6,51	6,19	5,89	5,93	6,18	5,87	6,23	6,47	6,17	6,51	6,22	6,28	6,19	6,18	6,31	6,15	5,93	5,87	6,18	6,01	5,92	6,20
5	4,56	2,70	3,21	3,15	2,17	1,99	2,15	1,29	1,37	1,93	1,42	3,18	3,03	2,38	1,57	2,15	2,22	2,65	3,05	2,98	2,38	2,34	1,33	1,19	2,81
6	3,30	6,53	6,17	5,84	6,22	5,71	5,19	5,72	5,55	6,15	5,43	5,86	5,36	5,85	6,17	5,98	5,73	5,34	5,75	6,18	5,99	5,88	6,19	5,87	6,20
7	4,56	1,20	1,15	1,23	1,49	1,39	1,25	1,37	1,32	1,47	1,35	1,27	1,27	1,33	1,37	1,33	1,28	1,39	1,29	1,19	1,42	1,15	1,30	1,45	1,33
8	5,73	2,03	2,03	2,05	1,98	2,71	2,33	1,95	2,93	1,96	1,05	1,52	1,47	1,39	1,35	2,08	2,34	1,58	1,37	1,27	1,17	1,19	1,98	1,73	1,68
9	4,64	3,21	3,37	3,95	3,22	3,33	3,35	3,38	3,20	3,52	3,19	3,47	3,39	3,03	3,00	3,47	2,98	3,03	3,41	3,38	3,05	,301	3,43	3,09	3,45
10	4,46	2,51	2,83	2,83	2,92	2,63	2,38	2,39	2,33	2,42	2,68	2,33	2,51	2,48	2,68	2,71	2,53	2,63	2,55	2,78	2,79	2,57	4,53	2,78	2,83
11	5,71	3,63	3,18	3,51	3,34	3,61	3,63	3,43	3,68	3,29	3,31	3,35	3,58	3,29	3,55	3,18	3,20	3,31	3,17	3,32	3,15	3,18	3,38	3,21	3,36
12	4,93	4,28	4,51	4,48	4,41	4,55	4,42	4,57	4,84	4,59	1,37	4,58	4,28	4,61	4,63	4,32	4,71	4,67	4,33	4,72	4,29	4,80	4,35	4,58	4,31
13	3,20	3,72	3,31	2,38	3,59	3,51	3,47	3,57	3,99	3,81	3,82	3,78	3,79	3,32	3,73	3,96	3,68	3,75	3,36	3,71	3,83	3,39	3,42	3,41	3,43
14	2,23	4,37	4,91	5,28	5,26	4,44	4,38	4,98	4,72	5,23	1,55	5,01	4,68	4,83	5,02	4,85	4,57	3,01	5,15	5,03	4,59	5,17	5,15	4,61	5,19
15	5,51	5,68	5,66	5,65	6,51	5,21	5,35	6,68	5,67	5,78	6,15	6,12	6,18	6,17	5,61	5,38	6,20	5,55	5,92	6,25	6,13	6,01	6,71	6,03	5,93
16	7,37	4,25	4,64	4,27	4,26	4,19	4,27	4,15	4,28	4,31	4,63	4,45	4,61	4,33	4,68	4,62	4,55	5,26	4,19	4,61	4,93	5,15	4,59	5,21	4,58
17	4,97	4,51	4,18	4,20	4,35	4,68	4,73	4,26	4,63	4,71	4,45	4,69	4,28	4,31	4,58	1,48	1,72	1,65	4,31	4,81	4,74	4,37	4,79	4,80	4,39
18	6,38	5,68	5,67	5,60	5,69	5,55	5,53	5,58	5,70	5,72	5,20	5,01	5,18	5,87	5,21	5,75	5,83	5,17	5,81	5,79	5,80	5,70	5,81	5,63	5,68
19	6,00	4,92	7,81	4,90	4,87	4,19	4,63	4,88	4,83	4,20	4,68	4,19	4,33	4,53	4,85	4,58	4,63	4,59	4,65	4,63	4,87	4,70	,170	4,71	4,89
20	1,20	3,25	3,31	3,38	3,42	3,32	3,15	3,40	6,16	3,29	3,28	3,50	3,30	3,70	3,68	3,51	3,35	3,72	3,52	3,65	3,74	3,53	3,41	3,68	3,69
21	7,12	2,73	2,81	2,83	2,68	2,54	2,47	2,37	2,43	2,55	4,48	2,81	2,57	2,35	2,57	2,33	2,87	2,41	2,38	2,40	2,89	2,31	2,33	2,93	2,22
22	1,23	5,33	5,83	5,77	5,90	5,81	5,34	5,55	5,35	5,49	5,33	5,51	5,36	5,68	5,43	5,41	5,67	5,78	5,38	5,45	5,47	5,61	5,44	5,80	5,46
23	2,94	2,35	2,63	2,36	3,01	2,62	2,80	2,81	2,72	2,91	2,78	2,95	2,92	2,38	2,93	2,88	2,97	2,77	2,42	2,88	2,97	2,99	2,44	2,99	2,46
24	1,49	1,29	1,28	1,50	1,47	1,55	1,63	1,30	1,59	1,42	1,53	1,32	1,68	1,63	1,33	1,57	1,34	1,32	1,68	1,37	1,36	1,45	1,73	1,38	1,52
25	1,40	2,01	1,41	1,68	1,52	1,70	1,38	1,63	2,02	2,08	1,63	3,98	1,96	1,67	1,55	1,59	1,57	1,68	1,69	1,63	1,65	1,70	1,69	1,71	1,80
26	2,50	2,71	2,81	2,87	2,9	2,93	2,91	2,59	2,57	2,63	2,73	2,55	2,83	2,78	2,75	2,67	2,79	2,76	2,80	2,83	2,85	2,77	2,87	2,89	2,88
27	2,27	3,21	2,28	3,05	2,38	2,39	3,07	2,29	2,35	2,37	2,30	2,33	2,37	3,15	3,17	2,43	2,39	2,59	2,63	2,40	2,67	2,43	2,80	2,83	2,47
28	5,63	4,80	4,89	5,55	5,57	5,50	5,62	5,60	5,98	5,97	5,93	5,71	6,02	5,73	5,72	5,75	5,89	5,88	5,81	5,71	5,63	5,67	5,91	5,82	5,71
29	3,21	3,10	3,12	3,47	3,13	3,51	3,38	3,39	3,58	3,59	3,27	3,15	3,28	3,37	3,29	3,47	3,48	3,17	3,90	3,96	3,98	3,19	3,97	3,46	3,22

Appendix A

No	Area of quarters, hectares																								
	Variant No.																								
	1	2	3	4	5	6	7	8	9	10	11	12	13	14	15	16	17	18	19	20	21	22	23	24	25
30	4,70	4,20	4,27	4,75	4,19	4,71	4,93	4,62	4,73	4,82	4,63	4,97	4,68	4,65	4,59	4,92	4,43	4,67	4,33	4,88	4,38	4,68	4,39	4,73	4,47
31	5,70	5,62	5,63	5,81	5,67	5,80	5,79	5,87	5,68	5,71	4,93	4,98	5,69	5,73	4,99	5,75	5,60	5,03	5,07	5,72	5,67	5,65	5,73	5,84	5,79
32	3,31	3,72	3,30	3,33	3,49	3,33	3,47	3,32	3,41	3,47	3,35	3,49	3,98	3,51	3,38	3,42	3,37	3,38	3,57	3,88	3,95	3,39	3,97	3,59	3,43
33	3,80	3,31	3,30	3,70	3,68	3,69	3,92	3,52	3,73	3,68	3,57	3,97	3,75	3,79	3,43	3,80	3,45	3,96	3,47	3,66	3,49	3,65	3,95	3,63	3,87
34	3,90	3,57	3,88	3,58	3,73	3,87	3,62	3,71	3,58	3,72	3,85	3,98	3,68	3,70	3,69	3,83	3,63	3,91	3,59	3,93	3,81	3,85	3,89	3,79	3,87
35	5,60	5,70	5,52	5,71	5,82	5,81	5,73	5,75	5,69	5,70	5,77	5,68	5,70	5,75	5,61	5,62	5,78	5,79	5,73	5,81	5,83	5,67	5,90	5,91	5,68
36	6,20	6,12	6,29	6,16	6,02	6,31	6,19	6,34	6,01	6,36	6,42	6,00	6,17	6,22	6,03	6,27	6,05	6,40	6,15	6,37	6,28	6,07	6,34	6,31	6,33
<i>P</i> , People/ha	295	300	305	290	280	260	270	275	265	280	285	290	300	305	310	285	275	265	280	285	290	300	305	300	280

Appendix B Reference material

Table B.1 – Values of coefficient β

Number of residents, thousand people.	1	1,5	2,5	4	6	10	20	50	100	300	1000 or more
β max.	2	1,8	1,6	1,5	1,4	1,3	1,2	1,15	1,1	1,05	1
β min.	0,1	0,1	0,1	0,2	0,25	0,4	0,5	0,6	0,7	0,65	1

Table B.2 – Water consumption for irrigation

Purpose of water	Meter	Water consumption for irrigation, l/m ²
Mechanised washing of improved pavement and square surfaces	1 sink	1,2–1,5
Mechanised watering of improved pavement and square surfaces	1 tap	0,3–0,4
Manual watering (with hoses) of improved pavement and square surfaces	1 tap	0,4–0,5
Watering of urban green spaces	1 tap	3–4
Watering of lawns and flower beds	1 tap	4–6

Table B.3 – Table of marginal costs (compiled by N. N. Abramov based on L. F. Moshnin's formulas)

D, mm	Limiting economic costs, l/s		Limiting economic speeds, m/s	
	minimum	maximum	minimum	maximum
100	–	5,4	–	0,71
125	5,4	9,0	0,45	0,73
150	9,0	15,0	0,51	0,85
200	15,0	28,5	0,48	0,91
250	28,5	45,0	0,53	0,92
300	45,0	68,0	0,64	0,96
350	68,0	96,0	0,71	1,00
400	96,0	130,0	0,76	1,04
450	130,0	168,0	0,82	1,06
500	168,0	237,0	0,86	1,21
600	237,0	355,0	0,84	1,26
700	355,0	490,0	0,93	1,27
800	490,0	685,0	0,98	1,36
900	685,0	882,0	1,07	1,38
1000	882,0	1120,0	0,12	1,46
1100	1120,0	1390,0	1,22	–
1200	1390,0	–	1,22	–

1.3.1.

$$Q_{AH} = \frac{0,045 N_{h.w}}{24} + \frac{0,025 N_{c.w}}{24} = \frac{0,045 \cdot 3500 + 0,025 \cdot 1500}{24}$$

$$= 8,13 \text{ m}^3/\text{hour} \quad (1.11)$$

$$Q_{MH} = \frac{0,045 \cdot N_{h.w} \cdot K_{h.w} + 0,025 N_{c.w} \cdot K_{c.w}}{T_{w.s}} \quad (1.12)$$

$$(1.12) \quad Q_{MH} = \frac{0,045 \cdot 1820 \cdot 2,5 + 0,025 \cdot 780 \cdot 3}{8} = 32,91 \text{ m}^3/\text{hour}$$

$$(1.8) \quad Q_{MS} = 32,91 / 3,6 = 9,14 \text{ l/s}$$

1.3.2

$$Q_{MD} = EP \cdot g_p = 120 \cdot 5 = 600 \text{ m}^3/\text{day} \quad (1.13)$$

$$Q_{MH} = Q_{MD} / 24 = 600 / 24 = 25 \text{ m}^3/\text{hour} \quad (1.5)$$

$$Q_{MS} = 25 / 3,6 = 6,9 \text{ l/s} \quad (1.8)$$

1.3.3

$$(1.16) \quad Q_{w.s} = (0,06 V_{h.w} + 0,04 V_{h.c.}) = 0,06 \cdot 650 + 0,04 \cdot 130 = 44,2 \text{ m}^3$$

$$(1.15) \quad Q_{MH} = \frac{Q_{w.s}}{0,75} = \frac{44,2}{0,75} = 58,93 \text{ m}^3/\text{hour}$$

$$(1.8) \quad Q_{MS} = 58,93 / 3,6 = 16,37 \text{ l/s}$$

Table 1.2

	Q_{MD}	Q_{AH}	Q_{MH}	Q_{MS}
1	15095,5	8,13	32,91	9,14
2	106,74	—	58,93	16,37
3	600	—	25	6,9
\bar{T}	—	—	116,84	32,41

Table 1.3

	Q_{MD}	Q_{AH}	Q_{MH}	Q_{MS}
1	15095,5	628,98	950,52	264,03
2	106,74	4,4	19,8	5,5
3	—	—	116,84	32,41
4	754,8	31,4	47,53	13,2
\bar{T}	—	—	1134,6	315,14

(2)

$$2.1 \quad Q_{sp} = \frac{Q - q_{conc}}{\sum L} \quad \text{l/s} \cdot \text{m}$$

$$2.2 \quad Q = Q_{sp} \cdot L \quad \text{l/s}$$

$$2.3 \quad Q_n = 0,5 \sum Q_k \quad \text{l/s}$$

$$2.4 \quad Q = Q_k = Q_n$$

$$\sum L = 800 + 995 + 845 + 1050 + 860 + 1185 + 1200 = 6865 \text{ m}$$

$$2.1 \quad Q_{sp} = (315,14 - 32,41) : 6865 = 0,0412$$

$$2.2 \quad 0,0412 \cdot 800 = 32,91 \quad (1-2)$$

$$0,0412 \cdot 995 = 40,98 \quad (2-3)$$

$$0,0412 \cdot 845 = 34,82 \quad (3-4)$$

$$0,0412 \cdot 1050 = 43,21 \quad (4-5)$$

$$0,0412 \cdot 860 = 35,43 \quad (5-6)$$

$$0,0412 \cdot 1185 = 48,97 \quad (6-1)$$

$$0,0412 \cdot 1200 = 49,41 \quad (3-6) \quad \leq 282,73 \text{ l/s}$$

$$2.3 \quad (32,91 + 48,97) : 2 = 39,53 \quad (1)$$

$$(32,91 + 40,98) : 2 = 36,90 \quad (2)$$

$$(40,98 + 34,82 + 49,41) : 2 = 62,55 \quad (3)$$

$$(34,82 + 43,21) : 2 = 39,02 \quad (4)$$

$$(43,21 + 35,43) : 2 = 39,42 \quad (5)$$

$$(35,43 + 49,41 + 48,97) : 2 = 65,31 \quad (6) \quad \leq 282,73 \text{ l/s}$$

Qcalc

$$(4) \quad 39,02 + 32,41 = 71,43 \Rightarrow 3-4 = 35,0 ; 5-4 = 36,43$$

$$6-5 = 36,43 + 39,42 = 75,85$$

$$2-3 + 3-6 = 3-4 + (3) \Rightarrow 2-3 = 52,55 ; 3-6 = 45,0$$

$$1-2 = 2-3 + (2) = 52,55 + 36,9 = 89,45$$

$$1-6 = 3-6 + 6-5 + (6) = 45,0 + 75,85 + 65,31 = 186,16$$

$$Q = 1-2 + 1-6 + (1) = 89,45 + 186,16 + 39,53 = 315,14$$

$$2.4 \quad 315,14 - 32,41 = \sum Q_k (282,73) = \sum Q_n (282,73)$$

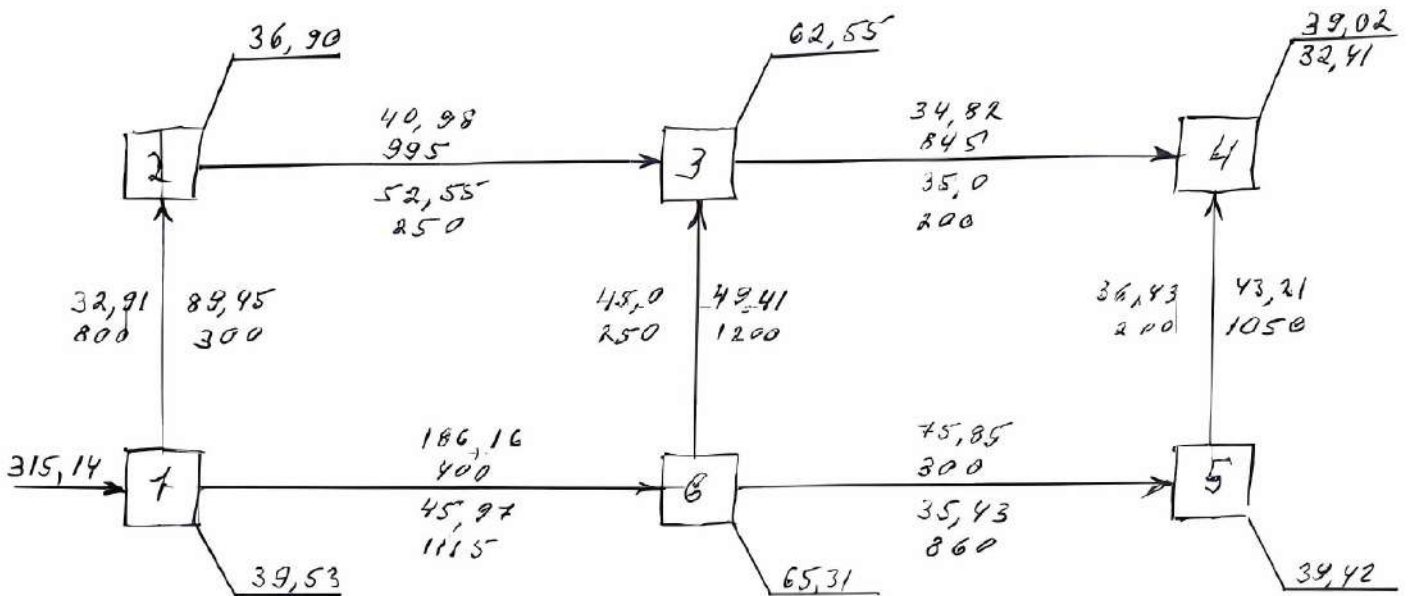
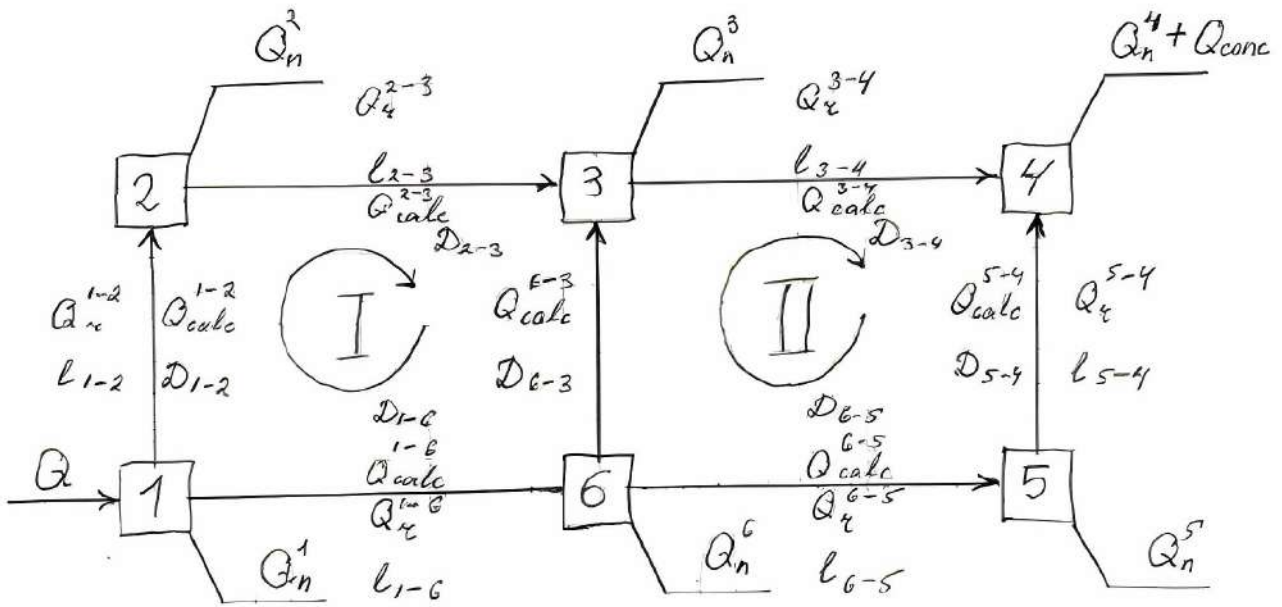

$$P = 295 \text{ people/ha}$$

$$F = 146,2 \text{ ha}$$

$$g = 350 \text{ l/day person}$$

$$EP = 120 \text{ t/day}$$

$$N = 5000 \text{ w}; N_{\text{max}} = 2000 \text{ w}$$

$$g_p = 5 \text{ m}^3/\text{t}$$

$$N = FP = 146,2 \times 295 = 43130 \text{ people (1.1)}$$

$$F = \Sigma \text{ area of the quarters} = 146,2 \text{ ha}$$

$$F_{ga} = 0,08 F = 0,08 \times 146,2 = 11,7 \text{ ha (1.2)}$$

$$F_{ss} = 0,15 F = 0,15 \times 146,2 = 21,9 \text{ ha (1.3)}$$

$$Q_{AD} = N g / 1000 = 43130 \times 350 / 1000 = 15095,5 \text{ m}^3/\text{day (1.4)}$$

$$Q_{AH} = Q_{AD} / 24 = 15095,5 / 24 = 628,98 \text{ m}^3/\text{hour (1.5)}$$

$$Q_{MH} = \frac{0,417 N \cdot K_h \cdot g}{1000} \text{ (1.6)}$$

$$K_h = \alpha \cdot \beta \text{ (1.7)}$$

$$\beta = \frac{43130 - 20000}{50000 - 20000} (1,15 - 1,2) = 1,16 \text{ (www.radformation.com/ tools/interpolation-calculator)}$$

$$K_h = 1,3 \times 1,16 = 1,51$$

$$Q_{MH} = 0,417 \times 43130 \times 1,51 \times 350 / 1000 = 950,52 \text{ m}^3/\text{hour (1.6)}$$

$$Q_{MS} = Q_{MH} / 3,6 = 950,52 / 3,6 = 264,03 \text{ l/s (1.8)}$$

1.2.1

$$Q_{MD} = \frac{F \cdot g \cdot n}{1000} \text{ (1.9)}$$

$$Q_{MD} = 219000 \cdot 0,3 \cdot 2 \cdot 0,1 / 1000 = 13,14 \text{ m}^3/\text{day}$$

$$Q_{AH} = 13,14 / 24 = 0,5 \text{ m}^3/\text{hour (1.5)}$$

$$Q_{MH} = 0,417 \cdot 219000 \cdot 4 \cdot 0,3 \cdot 2 \cdot 0,1 / 1000 = 2,2 \text{ m}^3/\text{hour (1.6)}$$

$$Q_{MS} = 2,2 / 3,6 = 0,6 \text{ l/s (1.8)}$$

1.2.2

$$(1.9) \quad Q_{MD} = 117000 \cdot 4 \cdot 2 \cdot 1 / 1000 = 93,6 \text{ m}^3/\text{day}$$

$$(1.5) \quad Q_{AH} = 93,6 / 24 = 3,9 \text{ m}^3/\text{hour}$$

$$(1.6) \quad Q_{MH} = 0,417 \cdot 117000 \cdot 4 \cdot 3 \cdot 2 \cdot 0,1 / 1000 = 17,6 \text{ m}^3/\text{hour}$$

$$(1.8) \quad Q_{MS} = 17,6 / 3,6 = 4,9 \text{ l/s}$$

№ rings	№ of the ring	Length of the blade l, m	Diameter D, mm	Resistivity $A \times 10^{-6}$	Preliminary cost allocation						1 correction			
					$q, l/s$	$v, m/s$	k	$S = A \cdot k \cdot l \cdot 10^{-3}$	$h = \frac{S \cdot q^2}{1000}$	$S \cdot q \cdot 10^{-3}$	$\Delta q, l/s$	$q, l/s$	$h = S \cdot q^2$	$S \cdot q \cdot 10^{-3}$
1	2	3	4	5	6	7	8	9	10	11	12	13	14	15
I	1-2	800	300	0,986	89,45	1,24	0,959	0,7565	+6,05	67,67	+1,48	90,93	+6,25	68,79
	2-3	995	250	2,638	52,55	1,05	0,994	2,6091	+7,21	137,11	+1,48	54,03	+7,62	140,97
	3-6	1200	250	2,638	45,00	0,90	1,021	3,2321	-6,55	145,44	-1,48-2,19	41,33	-5,52	133,58
	6-1	1115	400	0,219	186,16	1,47	0,930	0,2271	-7,87	42,28	-1,48	184,68	-7,75	41,94
									-1,16	392,50			+0,60	385,28
					$\Delta h = -1,16 \quad \sum S \cdot q = 392,50 \cdot 10^{-3}$						$\Delta h = +0,60 \quad \sum S \cdot q = 385,28 \cdot 10^{-3}$			
					$\Delta q_1 = \frac{-1,16}{2 \cdot 392,5 \cdot 10^{-3}} = +1,48$						$\Delta q_1 = \frac{+0,60}{2 \cdot 385,28 \cdot 10^{-3}} = -0,79$			
II	3-4	1200	200	8,608	35,00	1,09	0,990	10,2263	+12,53	357,92	-2,19	32,81	+11,09	335,52
	4-5	845	200	8,608	36,43	1,13	0,981	7,1356	-9,47	259,95	+2,19	38,62	-10,64	275,58
	5-6	1050	300	0,986	75,85	1,04	0,995	1,0301	-5,93	78,13	+2,19	78,04	-6,27	80,39
	6-3	1200	250	2,638	45,00	0,90	1,021	3,2321	+6,55	145,44	-2,19-1,48	41,33	+5,52	133,58
									+3,68	841,44				825,07
					$\Delta h = +3,68 \quad \sum S \cdot q = 841,44 \cdot 10^{-3}$						$\Delta h = -0,30 \quad \sum S \cdot q = 825,07 \cdot 10^{-3}$			
					$\Delta q_2 = \frac{+3,68}{2 \cdot 841 \cdot 10^{-3}} = -2,19$						$\Delta q_2 = \frac{-0,30}{2 \cdot 825,07 \cdot 10^{-3}} = +0,18$			

№ rings	№ of the ring	2 correction				3 correction				4 correction			
		$\Delta q, \text{V/s}$	$q, \text{V/s}$	$h = S \cdot q^2$	$S \cdot q \cdot 10^{-3}$	$\Delta q, \text{V/s}$	$q, \text{V/s}$	$h = S \cdot q^2$	$S \cdot q \cdot 10^{-3}$	$\Delta q, \text{V/s}$	$q, \text{V/s}$	$h = S \cdot q^2$	$S \cdot q \cdot 10^{-3}$
16	17	18	19	20	21	22	23	24	25	26	27	28	29
I	1-2	-0,79	90,14	+6,15	68,19	+0,05	90,19	+6,15	68,23	-0,43	89,76	+6,10	
	2-3	-0,79	53,24	+7,40	138,91	+0,05	53,29	+7,41	139,04	-0,43	52,86	+7,29	
	3-6	+0,79+0,18	42,30	-5,78	136,72	-0,05-1,30	40,95	-5,42	132,35	+0,43+1,24	42,62	-5,87	
	6-1	+0,79	185,47	-7,81	42,12	-0,05	185,42	-7,81	42,11	+0,43	185,85	-7,84	
				-0,04	385,94			+0,33	381,73			-0,32	
		$\Delta h = -0,04 \quad \sum S \cdot q = 385,94 \cdot 10^{-3}$ $\Delta q_1 = \frac{-0,04}{2 \cdot 385,94 \cdot 10^{-3}} = +0,05$				$\Delta h = +0,33 \quad \sum S \cdot q = 381,73 \cdot 10^{-3}$ $\Delta q_1 = \frac{+0,33}{2 \cdot 381,73 \cdot 10^{-3}} = -0,43$				$\Delta h = -0,32$			
II	3-4	+0,18	32,99	+11,13	337,37	-1,30	31,69	+10,27	324,07	+1,24	32,93	+11,09	
	4-5	-0,18	38,44	-10,54	274,29	+1,30	39,74	-11,27	283,57	-1,24	38,50	-10,58	
	5-6	-0,18	77,86	-6,24	80,20	+1,30	79,16	-6,45	81,54	-1,24	77,92	-6,25	
	6-3	+0,18+0,79	42,30	+7,81	136,72	-1,30-0,05	40,95	+5,42	132,35	+1,24+0,43	42,62	+5,87	
				+2,16	828,58			-2,03	821,53			+0,13	
		$\Delta h = +2,16 \quad \sum S \cdot q = 828,58 \cdot 10^{-3}$ $\Delta q_2 = \frac{+2,16}{2 \cdot 828,58 \cdot 10^{-3}} = -1,30$				$\Delta h = -2,03 \quad \sum S \cdot q = 821,53 \cdot 10^{-3}$ $\Delta q_2 = \frac{-2,03}{2 \cdot 821,53 \cdot 10^{-3}} = +1,24$				$\Delta h = +0,13$			