



Co-funded by the
Erasmus+ Programme
of the European Union



**COMBINING SCIENCE, EDUCATION,
AND INDUSTRY AS A WAY TO CREATE
AN EFFECTIVE MECHANISM FOR
PREVENTING CLIMATE CHANGE**

Monograph
English edition

MINISTRY OF EDUCATION AND SCIENCE OF UKRAINE

**KHARKIV NATIONAL AUTOMOBILE
AND HIGHWAY UNIVERSITY**

**COMBINING SCIENCE, EDUCATION,
AND INDUSTRY AS A WAY TO CREATE
AN EFFECTIVE MECHANISM FOR
PREVENTING CLIMATE CHANGE**

Kharkiv 2024

Reviewers:

Anatoliy HRYTSENKO – Doctor of Geographical Sciences, Professor, Director of the Scientific Research Institution "Ukrainian Scientific Research Institute of Ecological Problems", Ukraine

Yuliia ZGHURSKA – Deputy Director of the International Cooperation Department of Kharkiv City Council, Ukraine

Mira PUCAREVICH – Professor, Dean of the Faculty of Environmental Protection, Educons University, Serbia

Combining science, education, and production as a way to form an effective mechanism for preventing climate change: collective monograph (Engl. edition)

/ by general ed. N. Vnukova, N. Prokopenko. - Kharkiv: Publ. House «Smugasta Typography 2024. - 174 c.

The collective monograph was prepared by researchers from the partner universities of the international ERASMUS+ project “Synergy of educational, scientific, managerial and industrial components for climate management and climate change prevention / CLIMAN” 619119-EPP-1-2020 -1-NL-EPPKA2-CBHE-JP.

The publication highlights the results of our own research on the general issues and origins of global climate change, sectoral issues of sustainable development, the introduction of natural solutions, the application of innovative approaches to energy supply for the development of transport, agriculture and resource conservation.

The monograph is intended for a wide range of readers who are interested in the problems of global climate change, as well as ways to prevent, adapt and minimize the effects of climate change.

© Kharkiv National Automobile and Highway University, 2024

Combining science, education, and production as a way to form an effective mechanism for preventing climate change

INTRODUCTION

Climate change is a global challenge for the entire world, a global problem that poses serious threats to the international economy and security. It is currently accelerating processes that lead to increased risks in the areas of energy security, access to food and drinking water, ecosystem stability, and threats to human health and life.

Over the past decade, climate change has become one of the most pressing issues in the global economy and politics due to the low ability of countries to adapt to extreme climate change, such as floods, droughts and other events that could lead to social and economic instability in the world, which requires the development of appropriate policies and strategies to reduce greenhouse gas emissions and transition to low-carbon development in all sectors of the economy and areas of human life.

According to meteorological data, the average air temperature in Ukraine, as well as in the rest of the world, is on the rise. There is also a tendency to increase the frequency and duration of periods with high air temperatures, which significantly affects the health and livelihoods of people in Ukraine. The increase in air temperature leads, in particular, to an increase in the frequency and intensity of convective weather events, such as thunderstorms, heavy precipitation, hail, and squalls. These phenomena are sometimes recorded in months and seasons when they have not occurred before, and spread to areas where they have never been observed before.

Ukraine is vulnerable to hazardous and natural hydrometeorological events such as rainfall, floods and coastal inundation, including agricultural and urban flooding, mudflows and mudslides, and landslides. Such hazards are phenomena lead to human casualties, significant damage and destruction of infrastructure.

The purpose of the Strategy for the Formation and Implementation of the State Climate Change Policy until 2035, adopted by the Cabinet of Ministers of Ukraine in 2024, is to create an organisational and legal framework for the formation and

Combining science, education, and production as a way to form an effective mechanism for preventing climate change

implementation of the state climate change policy to achieve sustainable development and ensure an effective transition to low-carbon development of the state, subject to economic, energy and environmental security and improving the welfare of citizens, and to take into account the goals of the state climate policy during the post-war reconstruction of Ukraine.

As a party to the United Nations Framework Convention on Climate Change and the Paris Agreement, Ukraine is currently fulfilling its current obligations under these international agreements, but its climate change policy is fragmented and often considered as a component of environmental policy alone. The absence of a systematic approach to climate change in general makes it impossible to make management decisions to ensure climate change mitigation and adaptation across the country's economy. Further implementation of the provisions of the Paris Agreement requires the development of a coherent and consistent state policy on climate change in line with the policies of international organisations, taking into account the world's leading technologies and practices, as well as the specifics of national conditions, capabilities, needs and priorities.

Ideas to reduce the pace of climate change and mitigate its effects should be implemented through international cooperation, including in the field of education. One of the key projects in this area is the Erasmus+ project «**Synergy of educational, scientific, management and industrial components for climate management and climate change prevention/ CLIMAN**» 619119-EPP-1-2020-1-NL-EPPKA2-CBHE-JP. The project envisaged training of qualified climate managers. For this purpose, project teams will study best EU practices, select and train staff, update existing Master degree programs in environmental protection and management by developing an interdisciplinary training module in climate change prevention, adaptation and mitigation.

Project duration: 15.11.2020-14.11.2024

The **aim of the project** is to help the universities of Georgia and Ukraine to become centers for the development of research of climate management to accelerate

Combining science, education, and production as a way to form an effective mechanism for preventing climate change

integration into the global climate market and to meet global climate regulation requirements by acquiring best European practices in the field of climate change prevention, adaptation and mitigation.

The specific objectives of the project are as follows:

1. Update the existing master degree programs by developing an interdisciplinary training module "Climate Management".
2. Establish consulting Climate Management Centers at partner universities and ensure their sustainable development.
3. Facilitate the development and strengthening of institutional capacity of partner universities aiming to develop recommendations for the industrial, transport, energy, tourism sectors and local authorities in the sphere of climate change prevention, adaptation and mitigation.

Activities:

1. Learning of the EU experience in scientific and practical activities on climate management.
2. Development of the Training Module "Climate Management" at Partner HEIs.
3. Establishment of the Climate Management Center.
4. Implementation of the updated Master Degree Program at Partner HEIs.
5. Quality Management.
6. Dissemination and sustainability.
7. Project Management.

Expected results:

1. Updated Master Degree Program by means of development and implementation of Training Module "Climate Management".
2. Trained staff.
3. Consulting Centers of Climate Management are established at partner universities.

Combining science, education, and production as a way to form an effective mechanism for preventing climate change

4. Developed “roadmap” of cooperation between the industrial, transport, agricultural and tourism sectors and local authorities on the implementation of climate management policy.

5. Qualified climate managers.

Partnership:

Grant holder: Netherlands Business Academy, the Netherlands

Co-coordinator of the project: KROK University, Ukraine.

- «HTW Berlin, University of Applied Sciences», Germany;
- Foggia University, Italy;
- Mykolas Romeris University, Lithuania;
- Turība University, Latvia;
- Kharkiv National Automobile and Highway University, Ukraine;
- Lviv Polytechnic National University, Ukraine;
- Akaki Tsereteli State University Kutaisi, Georgia;
- Batumi Shota Rustaveli State University, Georgia;
- West Ukrainian National University, Ukraine;
- Hultgren Nachhaltigkeitsberatung UG, Germany .

Project site: <https://climancoordinator.wixsite.com/climan>



CHAPTER 1

CLIMATE CHANGE AND ENERGY

Combining science, education, and production as a way to form an effective mechanism for preventing climate change

SECTION 1.1 GENERAL ISSUES OF CLIMATE CHANGE IMPACT ON THE ENERGY SECTOR

Jan van Zwieten,

Rector of the Netherlands Business Academy, Netherlands

Nataliia Vnukova

Kharkiv National Automobile and Highway University, Ukraine

Lotariev Andrii,

«KROK» University, Ukraine

Currently, the problem of climate change is so urgent and important that it is considered from various aspects: educational, economic, industrial, social and political . There is scientific evidence that the climate has changed over the past 150 years, mostly due to human activity. Global temperatures are rising, precipitation is becoming more unpredictable, the number of extreme natural events is increasing, and their nature and intensity are becoming difficult to predict [1].

Climate change is predicted to intensify in all regions of the world in the coming decades, with heat waves, extended warm seasons and shorter cold seasons expected. According to the IPCC (Intergovernmental Panel on Climate Change), significant, rapid and sustained reductions in greenhouse gas emissions and the achievement of zero CO₂ emissions are needed to stabilise the climate. Limiting emissions of other greenhouse gases and air pollutants, such as methane, will have a positive impact on both human health and the climate.

The IPCC report emphasises that in order to limit man-made global warming to a certain level, it is necessary to reduce total carbon dioxide emissions to net zero CO₂, as well as significantly reduce other greenhouse gas emissions. Substantial,

*Combining science, education, and production as a way to form an effective
mechanism for preventing climate change*

rapid and sustained reductions in methane emissions will also help to limit the warming effect of reduced aerosol pollution.

The current climate policy of the European Union is as follows. In June 2021, the European Council adopted the European Climate Law proposed by the European Commission, which sets a new, more ambitious target: to reduce greenhouse gas emissions by at least 55% by 2030 compared to 1990 levels.

The law envisages achieving zero greenhouse gas emissions for the EU as a whole by reducing emissions, investing in green technologies and protecting the environment. It ensures that EU policies contribute to this goal and that all economic and social sectors play their part.

The European Climate Law aims to:

- define a long-term strategy for achieving climate neutrality by 2050 in a socially just and cost-effective way;
- establish a system to monitor progress and take further action if necessary;
- ensure predictability for investors and economic actors;
- guarantee the irreversibility of the transition to climate neutrality [2].

To achieve decarbonisation targets, emissions need to be reduced across all sectors, from industry and energy to transport and agriculture. In addition to mitigating the effects of climate change, the EU is also taking adaptation measures to ensure that it is as prepared as possible for its inevitable consequences.

On 14 July 2021, the European Commission presented a programme to combat climate change until 2050, called Fit for 55. According to this programme, it is planned to reduce carbon dioxide emissions in all sectors of the European economy, including electricity generation, the automotive and residential sectors, as well as shipping, aviation and agriculture. By 2030, the EU's emissions are to be reduced by 55% from 1990 levels, and by 2050 they are to be brought to zero.

One of the main aspects of the Fit for 55 programme is the introduction of a cross-border carbon regulation mechanism, which levies customs duties on goods imported into the EU depending on their carbon footprint. This is intended to protect

Combining science, education, and production as a way to form an effective mechanism for preventing climate change

European producers, as stricter climate regulations in the EU increase their costs and worsen their competitive position compared to producers from countries with less stringent regulations.

The EU's new climate policy aims to accelerate the reduction of greenhouse gas emissions over the next decade. The policy includes: expanding the emissions trading system to new sectors and strengthening the current EU emissions trading system; increasing the use of renewable energy; improving energy efficiency; faster deployment of low-emission vehicles and related infrastructure and fuels; aligning tax policy with EGD targets; measures to prevent carbon leakage; and instruments to preserve and enhance natural carbon sinks.

The priorities of Ukraine's climate policy should take into account the opportunities of the European Green Deal for climate change adaptation in Ukraine and the integration of climate priorities into the country's socio-economic development programmes. On 5 November 2021, the Verkhovna Rada of Ukraine adopted the Resolution 'On the Address of the Verkhovna Rada of Ukraine to the United Nations Climate Change Conference', which includes the 26th session of the Conference of the Parties to the United Nations Framework Convention on Climate Change.

The address reaffirms the intention to achieve the goals of the Paris Agreement, namely to limit the increase in global average temperature to well below 2 °C and to aim for a limit of 1.5 °C. It points to the need to strengthen efforts to maintain this temperature threshold in order to avoid the worst effects of climate change, especially for the most vulnerable countries.

It also emphasises support for global climate change goals, in particular, maximising the availability and attractiveness of clean technologies and sustainable development solutions in every sector that emits pollutants by 2030.

Taking into account the commitments arising from the COP 26 climate summit in Glasgow, Ukraine's national climate policy will require adjustments in the following areas

Combining science, education, and production as a way to form an effective mechanism for preventing climate change

- updating legislation in the field of waste management and reducing greenhouse gas emissions;
- reduction of coal and other fossil fuels consumption, green transformation of industry;
- establishing a national emissions trading system in line with EU rules;
- establishing the Ukrainian Climate Fund;
- Reforming the environmental control system and adopting relevant legislation;
- forestry reform to increase the area of forests and implement measures to protect steppe ecosystems;
- development of measures to combat land degradation and increase the natural absorption of greenhouse gases [1].

The benefits of the European Green Deal (EGD) for Ukraine lie in the transformation of the country's current climate policy with a focus on achieving long-term and sustainable results that will ensure the development and competitiveness of the national economy. The successful implementation of the EGD opens up a number of potential benefits for Ukraine, such as facilitating the integration of Ukrainian production into new EU industrial processes through the introduction of an 'industrial visa-free regime', the development of organic production, and cooperation in the field of hydrogen energy. There is a potential for entering the European public procurement market, access to financial and technical instruments of EU support for climate change adaptation, integration of Ukraine's protected areas into the NATURA 2000 network through the creation of special financial instruments, and further establishment of Ukraine as a full-fledged participant in a climate-neutral Europe. 'The Energy Green Transition will stimulate the development of high-tech production, increase demand for goods and services related to clean technologies, and ensure the transformation of industrial production and export structure.

The impact of climate change on the development of the energy sector is manifested in the following aspects:

Combining science, education, and production as a way to form an effective mechanism for preventing climate change

- Climatic conditions largely determine the operation and technical and economic performance of all types of power plants, so climate change may require adjustments to the design and operation of power plants.

- Changing climate conditions affect energy demand, which can significantly change heat and power consumption in different regions.

- In the energy sector, it is virtually impossible to accumulate and store products, so energy needs must be forecasted and accounted for in advance.

- Climatic conditions have a significant impact on the environmental impact of energy facilities [1].

The reliability and availability of thermal power plants (TPPs) and nuclear power plants (NPPs) to operate efficiently and at their intended capacity are critical to ensuring energy security in the face of climate change and other unforeseen circumstances. Low-snow winters are becoming a problem for hydroelectric power plants (HPPs), as they reduce the volume of water in reservoirs and, as a result, electricity generation. The supply of fuel and water to TPPs and NPPs, as well as the efficiency of cooling their power units, largely depend on climatic factors. For example, an increase in precipitation can lead to the wetting of coal in open storage facilities, which reduces the thermal efficiency of power plants by 1-3%. On a national scale, this results in additional fuel consumption of up to 0.5-1.0 million tonnes in terms of standard fuel annually. Fluctuations in air temperature also have a significant impact on the efficiency of gas turbines: a 5°C increase in temperature reduces energy production by 1-4%. Changes in the frequency and intensity of hazardous weather events (tornadoes, heavy rain, extreme temperatures and wind speeds) can damage power plant units and pose a threat to surrounding communities.

Climate information in the thermal energy sector is used mainly in the design and construction of energy facilities. A large set of climatic parameters is taken into account when choosing a TPP location and a specific site for their construction. When determining the design capacity of a TPP based on steam power plants, it is mandatory to take into account the design air temperatures: the coldest and hottest

day. The continuous duration with 90%, 95%, and 99% of different combinations of temperature and relative humidity is also important [1].

Nuclear power plants are hazardous facilities where consideration of extreme weather impacts is critical to ensure reliability and safety. To accurately calculate the probabilities of extreme meteorological events, it is necessary to use observations for at least 100 years, as well as to take into account earlier data on hazardous events, if available in historical sources. NPP cooling processes are similar to those described for thermal power plants, but the risks of accidents and their possible consequences increase the requirements for the necessary climate information. When designing and operating a nuclear power plant, the availability indicators are taken with a large margin. Adverse meteorological conditions, such as hurricanes, typhoons, tornadoes, extreme temperatures, ice, lightning, avalanches, snow and extreme wind loads, are taken into account when selecting a site for a plant, with a 0.01% reliability (recurrence rate of 1 in 10,000 years).

The main calculated characteristics of the hydrological regime for water bodies that support the operation of nuclear power plants include maximum observed and calculated water discharges, levels of rain floods and spring floods with a water availability of up to 0.01 %; minimum observed and calculated water discharges in winter and summer-autumn periods, as well as levels of different availability, including 97%; average annual runoff with different availability, including 97%; intra-annual distribution of runoff by seasons and months for years with 50%, 95% and 97% availability; and calculated maximum runoff discharges with availability up to 0.01%.

Hydropower generation has always been heavily influenced by climate. The natural and climatic conditions of the region determine the design of water retaining structures, the composition of the hydroelectric power plant, the operating modes of hydroelectric power plants (HPPs) and the use of water resources by other consumers. Both at the design stage and in the course of further operation of individual HPPs or cascades, it is important to take into account data on air

temperature and humidity, wind conditions, and precipitation, which determine the runoff and, consequently, the volume of water inflow into the reservoir and the levels in the upper and lower reaches. Information on extreme meteorological indicators, in particular, data on precipitation amounts of rare occurrence (1.0%, 0.1%), is of particular importance when designing spillway structures at hydropower plants.

In the process of economic justification of hydropower plant construction, changes in monthly precipitation affecting electricity generation are taken into account. Inflow rates during the high water period also depend to a large extent on the intensity of snowmelt. If the inflow exceeds the norm, idle water releases may be required; if the inflow is less than the norm, the reservoir may remain full until the end of the flood. In such cases, the shortfall in hydropower generation is compensated by the power of thermal power plants. HPP projects contain data on average monthly precipitation and maximum daily precipitation. Data on the recurrence of particularly dangerous precipitation in terms of intensity and duration, which can threaten hydraulic structures, is taken into account.

Changes in climatic conditions in a particular area can affect hydropower generation and operating conditions through the following factors:

- Changes in precipitation and evaporation can lead to changes in the volume of runoff and its annual course, for example, a shift in the spring flood to an earlier period.

- Changes in the intensity and frequency of extreme weather events (floods and droughts) can increase the cost of hydropower projects and change the operating conditions of hydropower plants.

- Changes in the movement of suspended sediments can increase turbine wear and tear and reduce power generation.

- Changes in the ice regime will affect the operating conditions of hydropower plants [2].

However, climate-related changes in river flows are of the greatest importance for hydropower generation. The generation of hydropower at specific hydropower

Combining science, education, and production as a way to form an effective mechanism for preventing climate change

plants in different years, given unchanged technical conditions and a stable economic situation, mainly depends on changes in the inflow of water to the reservoir. A decrease in inflow will lead to a decrease in hydropower generation, while an increase in inflow will lead to an increase in generation.

The impact of climate on fossil fuel energy production is mainly related to the efficiency of the generation cycle and the requirements for cooling systems of power units. This impact is driven by the need to heat and cool power plant units both during the Rankine cycle (a thermodynamic cycle of heat to work using a two-phase working fluid such as water, mercury or freon, including evaporation and condensation) and the Brayton cycle (a thermodynamic cycle describing the operation of gas turbine engines with a closed loop of gaseous working fluid).

One of the main indicators of the efficiency of generating capacities is the installed capacity factor (ICF) of power plants. This coefficient is determined by numerous factors, including the type of equipment installed, the structure and number of consumers, the level of heat load (for thermal power plants), the level of water in reservoirs (for hydropower plants), the competitiveness of electricity and heat prices, as well as the quality of operation, repairs, reconstruction and technical condition of equipment. Meteorological conditions also have a significant impact on the EWC. For example, an abnormal heat wave can lead to a reduction in the capacity of power units or their complete shutdown, as happened in 2011 in some regions of the United States and France.

The efficiency and reliability of thermodynamic cycles varies depending on the average ambient conditions, such as air and water temperature, pressure, humidity, and the optimal choice of cooling system. As the temperature rises, the specific volume of air and energy consumption in the compressor increases, resulting in a decrease in energy output. Higher air temperature reduces atmospheric pressure, which reduces fuel combustion efficiency due to insufficient oxygen concentration. Existing data shows that when the critical temperature is reached, there is a sharp decline in power output.

Combining science, education, and production as a way to form an effective mechanism for preventing climate change

Thus, ambient temperature has a significant impact on the efficiency of turbines, boilers and generating sets. notes that during a heat wave, the capacity of nuclear power plants can be reduced by more than 2% for a 1°C increase in air temperature due to the physical limitations of cooling systems associated with environmental regulations. An important aspect is the availability and quality of water used in power plant cooling systems, as this makes them vulnerable in conditions of limited water resources and competition with other water users. For example, in the US, each kilowatt-hour of electricity generated in the steam cycle requires about 94.6 litres of water. It is expected that by 2030, the availability of water resources in the US will decrease by 30% compared to 2005, while water consumption in cooling systems will increase by almost 50%. This is due to increased water loss through evaporation and a decrease in the volume of water returned to water bodies [1].

Rising water temperatures put limits on cooling systems at nuclear and thermal power plants, which can lead to risks to their normal operation. A 5°C increase in water temperature reduces the efficiency of a nuclear power plant by an average of 1%. NPPs and thermal power plants with direct-flow cooling systems are more vulnerable than those using closed cooling systems with cooling towers. Direct-flow systems discharge waste water into water bodies and return it back, usually at higher temperatures. Water discharge regulations require that the temperature of the used water be lowered, which leads to a reduction in power output. Otherwise, power plants can face fines and other sanctions. However, during extreme heat waves, warm water is allowed to be discharged to maintain power supply, despite the negative impact on the environment.

An example of the impact of temperature changes on NPP operations is the situation that occurred in the summer of 2003 in Europe, when France experienced one of the hottest heat waves in the history of meteorological observations. Air temperatures were 20-30% higher than average, reaching 40°C for two weeks in August. Low precipitation in July and high temperatures led to water shortages and

deterioration of operating conditions at thermal power plants and nuclear power plants. France, which has 19 NPPs providing 80% of its electricity, has experienced difficulties due to its dependence on the temperature of water in natural reservoirs. 14 of the 19 plants are located near inland water bodies, while the remaining five are near the sea. During the heatwave, water temperatures in rivers exceeded the permissible limits, which slowed down reactor cooling.

As a result, France was forced to reduce its generating capacity by 4,000 MW, which is equivalent to the capacity of four power units or 6% of all French NPPs. Seventeen reactors were shut down or reduced production due to restrictions on water intake and discharge of overheated water. In total, the reduction in nuclear electricity during the summer amounted to 5.3 TWh. Nuclear safety regulators allowed the discharge of water with a temperature of up to 30°C, which is significantly higher than the standard limit of 24°C. As a result, the country's electricity supply did not experience any significant disruptions, despite the increase in demand. However, France, as a key electricity producer in Europe, was forced to halve its energy exports to Switzerland, the United Kingdom, Italy, Belgium and Spain during peak hours [1].

Energy production and consumption are responsible for more than 75% of greenhouse gas emissions in the European Union. Therefore, decarbonising the energy system is critical to achieving the 2030 climate goals and the EU's long-term strategy to achieve carbon neutrality by 2050.

The European Green Deal focuses on three main principles of the transition to clean energy, which will help reduce greenhouse gas emissions and improve the quality of life of citizens:

- ensuring reliable and affordable energy supplies in the EU;
- developing an integrated, interconnected and digitalised EU energy market;
- prioritising energy efficiency, especially in buildings, and developing an energy sector based on renewable energy sources.

The main objectives of the European Commission to achieve these goals include

Combining science, education, and production as a way to form an effective mechanism for preventing climate change

- building interconnected energy systems and improving grid integration to support renewable energy sources;
- promoting innovative technologies and modern infrastructure;
- improving energy efficiency and environmental design of products;
- decarbonising the gas sector and supporting smart integration between sectors;
- empowering consumers and helping EU countries to overcome energy poverty;
- promoting EU standards and technologies on the global stage;
- developing the potential of offshore wind energy in Europe [2].

In order to reduce greenhouse gas emissions by at least 55% by 2030, it is necessary to increase the share of renewable energy and improve energy efficiency. Therefore, the European Commission proposes to increase the mandatory target for renewable energy sources in the energy sector to 40% and in the electricity market to 65%. During the transition period to green transformation, the EU should ensure the most efficient functioning of the gas market.

The transition to clean energy should involve consumers and bring them benefits. Renewable energy sources will play a key role in this. In particular, increasing offshore wind power generation is important through regional cooperation among EU member states. Smart integration of renewable energy sources, energy efficiency, and other sustainable solutions in specific sectors will help achieve decarbonization at minimal cost [3].

According to the State of the Energy Union 2021 report released by the European Commission in October 2021, renewables overtook fossil fuels as the main source of energy in the EU for the first time in 2020, generating 38% of electricity compared to 37% for fossil fuels. At the moment, 9 EU member states have already phased out coal, 13 others have committed to phase out, and 4 more are considering possible timelines.

However, renewable energy sources do not ensure the complete withdrawal of thermal power plants, which perform the function of peak maneuvering during hours of fluctuating electricity consumption. This issue became relevant in the EU in the summer of 2021, when northern Europe experienced a long windless period, which led to a decrease in wind power generation. To compensate for the shortage of energy from renewable sources, which accounted for 42% of EU generation in the second quarter of 2021, producers were forced to restart coal-fired power plants that were in reserve. This led to a 29% increase in electricity production at such plants in the third quarter of 2021 and a 19% increase in carbon dioxide emissions in the EU energy sector compared to the same period of the previous year [3].

The transition to climate neutrality requires smart infrastructure. Regulatory frameworks for energy infrastructure, including the TEN-E Regulation, need to be revised to ensure compliance with climate neutrality. This framework should promote the deployment of innovative technologies and infrastructure, such as smart grids, hydrogen networks or carbon capture, storage and utilization technologies, as well as energy storage and sector integration. Existing infrastructure and assets need to be updated to maintain their suitability and resilience to climate change.

Sectoral integration means linking different energy carriers - electricity, heat, cold, gas, solid and liquid fuels - to end uses such as construction, transportation or industry. This allows optimizing the energy system as a whole, not just decarbonizing and improving the efficiency of individual sectors. The new EU strategy combines various existing and new technologies, processes and business models, including ICT, digitalization, smart grids, meters and flexible markets.

Current hydrogen consumption in Europe is less than 2%, and it is mainly used to produce chemicals such as plastics and fertilizers. About 96% of hydrogen is produced from natural gas, which is accompanied by significant CO₂ emissions.

However, hydrogen can also be produced from renewable energy. Renewable hydrogen (“green” or clean) is expected to play a key role in decarbonization sectors

where other alternatives may not be possible or expensive. These sectors include transportation and energy-intensive industrial processes [1].

“Green hydrogen can be produced by electrolysis, using renewable electricity to split water into hydrogen and oxygen. Pure hydrogen can be used to replace fossil-based hydrogen in industrial processes or to produce new industrial products such as green fertilizers and steel. It can also be used in the transportation sector, especially in heavy and long-distance trucks, buses, ships and aircraft.

Pure hydrogen is also compatible with the electricity sector, which is increasingly being driven by renewable energy, providing long-term and large-scale storage, as well as adding flexibility to the energy system.

In July 2020, the European Commission presented the Hydrogen Strategy for a Climate Neutral Europe. This strategy outlines the EU's Hydrogen Roadmap to 2050 and integrates different areas of activity, covering research, innovation, production, infrastructure and the international dimension. It identifies how the production and use of renewable hydrogen can contribute to the decarbonization of the EU economy in a cost-effective manner in line with the EGD.

In addition, along with the Hydrogen Strategy, the European Clean Hydrogen Alliance was launched in 2020 as part of a new industrial strategy for Europe. The Alliance brings together industry, national and local authorities, civil society and other stakeholders. The main goal of this alliance is to realize hydrogen technologies by 2030 by connecting renewable and low-carbon hydrogen production, demand in industry, transport and other sectors, and ensuring hydrogen transmission and distribution.

A faster and more ambitious energy transition in the EU could facilitate accelerated changes in the Ukrainian energy sector. This includes the closure of coal mines, decommissioning of the outdated fleet of coal-fired power plants, and the transformation of coal regions.

At the COP 26 climate summit in Glasgow, more than 40 countries, including Ukraine, pledged to gradually phase out the use of coal in the energy sector. The

Combining science, education, and production as a way to form an effective mechanism for preventing climate change

agreement stipulates that larger economies should abandon coal generation by 2030, and smaller ones - by 2040 [1].

The refusal to use coal, announced at the Glasgow summit, creates a new set of problems for Ukraine that will need to be addressed. These include the loss of more than 50,000 jobs in the mining and electricity sectors, the transformation of coal regions and social protection for their residents, addressing socio-economic issues of territorial communities after the closure of coal mines, as well as systemic environmental problems such as waste and waste heaps management, pollution of water sources by mine water, and reclamation of areas affected by coal mining.

Achieving carbon neutrality is impossible without overcoming the crisis in energy markets, which impede the integration of Ukraine's energy systems with European ones.

REFERENCES

1. Climate Change: Consequences and Adaptation Measures: Analytical Report / [S.P. Ivaniuta, O.O. Kolomiets, O.A. Malynovska, L.M. Yakushenko]; edited by S.P. Ivaniuta - Kyiv: NISS, 2020. 110 p.

2. Communication from the European Commission on guidance to Member States on updating national energy and climate plans for 2021-2030 (2022/C 495/02) -<https://eurlex.europa.eu/legal-content/EN/TXT/PDF/?uri=CELEX%3A52022XC1229%2802%29&%3Bfrom>

3. Ogdanska O.D., Chernobryvets S.I. Prospects for green energy in the context of geopolitical changes // Economy and Society - 2024 - Issue 68.

**SECTION 1.2 MESOPHILIC ANAEROBIC
FERMENTATION OF BROADLEAF CATTAIL
SUSPENSIONS UTILIZING FERMENTED YEAST
PRODUCTION RESIDUES AS A STARTER CULTURE**

**Malovanyy Myroslav,
Zhuk Volodymyr,
Tymchuk Ivan,
Vronska Nataliya,
Kochubei Viktoria,**

Lviv Polytechnic National University, Ukraine

Biological wastewater treatment in different types of wetlands is actively applied for the treatment of surface runoff, domestic and industrial wastewater of various compositions [1]. In the case of uncontrolled development of these hydrobionts they can cause the strong secondary pollution of water bodies by the products of their biodegradation, leading to eutrophication [2]. Thus, all types of wetland plants, used for wastewater treatment, usually should be harvested to remove nutrients from the system [3].

Modern methods of zero waste sustainable recovery process from solid and wastewater feedstock using microbial energy generation systems, comprehensively analyzed in [4], are effective for nutrient recovery, heavy metal removal and for biofuels generation, mainly biohydrogen and biomethane. A new comprehensive review of the problem presented by Kurniawan et al. [5] indicates that macrophytes used in various types of wetlands are great agents of wastewater treatment due to their high nutrient uptake capability. Moreover plant biomass can be effectively converted into valuable products such as animal feed, biochar, biofuel and fertilizers [6]. Anaerobic digestion (AD) of aquatic plant biomass not only provides production

*Combining science, education, and production as a way to form an effective
mechanism for preventing climate change*

of heat and electricity [7], but also restores nutrients and organic matter for reuse in agriculture [8], effectively closing their cycle [9], which is a basic principle of sustainable development [10]. There are many results that confirm the high efficiency of wetlands planted by the common reed (*Phragmites australis*) as an effective natural mean of surface and wastewater treatment, which can be followed by anaerobic digestion of additional biomass and biomethane production [11]. Large-scale field studies, conducted in Narew National Park (Poland), indicated that common reed is the plant species with the highest biomass yield $9.78 \pm 1.66 \text{ t TS} \cdot \text{ha}^{-1} \cdot \text{year}^{-1}$ [9].

A number of studies indicate also the prospects for the use of broadleaf cattail (*Typha latifolia*) in such systems [12]. Broadleaf cattail is naturally occurring plant that is widespread in wetlands throughout Europe, and it is able to produce an aboveground peak biomass of 1-3 kg of dry matter per 1 m^2 annually. The biomass of *Typha latifolia* contains 39-44% of carbon, 5.4-5.7% of hydrogen and 0.83-1.3% of nitrogen, and its energy value is 17.3-18.2 MJ/kg. Along with low nitrogen content (<2%) broadleaf cattail has quite high relative content of P with N:P ratio in the range of 5-9 [13].

Specific methane yield (SMY) of six typical wetland species including *Typha latifolia* was comprehensively studied by Czubaszek et al. [14]. For each plant species, specific yield of biomethane at different values of the initial humidity of the substrate was obtained: for wet fermentation process with total solids (TS) content 5 wt.% and for dry fermentation process with TS=12%. Mesophilic anaerobic digestion was enhanced by the fermentation inoculum, sampled from a storage tank of digestate at biogas plant processing maize silage, and high ratios of inoculum volatile solids to substrate volatile solids was used in this study, namely 2:1 for the wet fermentation and 1:1 for the dry fermentation process. Specific biomethane yield in the wet process was obtained 20-50% higher than with dry fermentation for all 6 species of aquatic plants. Specific biomethane yields of $224\text{-}250 \text{ mL} \cdot \text{g}_{\text{VS}}^{-1}$ was obtained with wet fermentation of *Typha latifolia*, and $179\text{-}191 \text{ mL} \cdot \text{g}_{\text{VS}}^{-1}$ for dry

fermentation respectively. These values were almost equal to the SMY for digestion of *Phalaris arundinacea* suspension, and exceeded on (34-48)% the same results for *Phragmites australis*, with average SMY of $160 \text{ mL} \cdot \text{g}_{\text{VS}}^{-1}$ for wet fermentation and $138 \text{ mL} \cdot \text{g}_{\text{VS}}^{-1}$ for dry fermentation process [15].

Broadleaf cattail and other typical wetland aquatic plant species have high content of cellulose, hemicellulose in the conversion into glucose of 66.8%, 54.8% and 62.0% of cellulose, respectively, and lignin, so various types of physical, chemical, biological or combined pretreatment can be used to enhance their anaerobic decomposition [16]. Pretreatment of cattail harvested at constructed wetlands in the North Carolina using 4% NaOH, 1% H_2SO_4 , and by high temperature resulted high temperature pretreatment (at 180-190°C) was 2-5 times more effective comparing the temperature 121°C. Thermochemical pretreatment of sweet potato root waste was found to be effective in terms of increasing both specific biogas yield (by 33.9%) and methane content (by 52.4%), reducing at the same time the digester retention time from 22 to 16 days [17]. Thus, thermochemical pretreatment of plant biomass is productive, but at the same time it is particularly energy consuming.

Co-digestion of plant biomass with sewage sludge is also potentially effective due to the optimization of feedstock C/N ratio, and could enhance biogas production up to 50% [18]. However, the use of sewage sludge, which potentially contains a significant amount of toxic contaminants, imposes significant restrictions on the subsequent agricultural use of digestate. There are number of studies reporting the effective co-digestion of water plant biomass with agricultural residues such as rice straw and with food waste [19].

Perspective ways of the intensification of anaerobic digestion of lignocellulosic plant biomass is a pretreatment by fungi and enzymes. Rumen cultures are widely used for the biological pretreatment of wetland plant lignocellulosic biomass, which leads to higher solubilization of cellulose, hemicellulose, and sometimes lignin, resulting in an increase in biogas production [20].

The addition of anaerobically digested yeast-based biomass to aquatic plant suspensions can be also potentially effective. Two different yeast species (*Saccharomyces cerevisiae* and *Pichia stipitis*) were studied as inoculum for the anaerobic digestion of the sugars released by cattail cellulose to obtain bioethanol. Both strains produced similar amounts of ethanol (approximately 0.48% w/v), and glucose to ethanol yields for both strains were approximately 95% of the theoretical possible. Additives of the yeast strains in some cases were used successfully to increase biogas output in the anaerobic digestion of different types of food waste. Nzeteu et al. demonstrated that the anaerobic recovery of volatile fatty acids is a result of cooperative microbial activity involving fungi and bacteria [21].

This study hypothesizes the possibility of intensifying the process of anaerobic digestion of aquatic plant biomass using the inoculum, sampled from the anaerobic digester for processing yeast residues, containing mainly *Saccharomyces cerevisiae* yeast strain. The purpose of this study was to find experimentally in lab-scale conditions the effects of the dry mass content and of inoculum dosage on the specific biogas yield and on the degree of decomposition of volatile solids of broadleaf cattail in the process of mesophilic anaerobic digestion.

The following materials and methods were used in the study.

As for the materials, the following were used.

Water suspensions of broadleaf cattail were digested anaerobically to study the effect of yeast residues inoculum on the AD process. Broadleaf cattail sample was harvested in the Yaniv Lake wetland, Lviv region, Ukraine (49.92N; 23.75E). Plant biomass was shredded in a blender to the suspension with particles of not more than 2 mm. Content of total solids (TS) in the cattail suspension, measured by standard laboratory technique, was found equal to $132 \text{ g}\cdot\text{L}^{-1}$, and volatile solids (VS) – $93.1 \text{ g}\cdot\text{L}^{-1}$ or 70.5% from TS.

Inoculum sample was taken from the industrial digester of Lviv Yeast Company, Ukraine, which produces bakery yeasts, mainly of the species *Saccharomyces cerevisiae*. Distribution of TS and VS contents by size fractions is

presented in Table 1.2.1. Total TS content in the inoculum was equal to $69.48 \text{ g}\cdot\text{L}^{-1}$ and VS content – 66.7% from TS. Methanogenic activity of yeast inoculum was 0.46 kg COD per 1 kg VS per day.

Table 1.2.1 - Total solids and volatile solids in the yeast residues inoculum by fractions

Fraction	TS ($\text{g}\cdot\text{L}^{-1}$)	VS ($\text{g}\cdot\text{L}^{-1}$)	VS (%TS)
> 1.0 mm	4.08	0.557	13.65
0.56–1.0 mm	4.64	1.511	32.57
0.25–0.56 mm	11.10	7.242	65.24
< 0.25 mm	49.66	36.998	74.50
Total	69.48	46.308	66.65

Composition and main initial parameters of suspensions of broadleaf cattail and yeast inoculum before the digestion are presented in the Table 1.2.2. Two-parameter lab-scale study was done, including two values of TS content in suspensions (5 and 10 wt.%) and two dimensionless TS based mass fractions of inoculum X_{in} (0.05 and 0.2). Mesophilic AD process of four suspensions with different combinations of these two parameters was studied, and four different values of inoculum TS content in the range 0.25-2.0 wt.% were obtained. Total initial mass of all samples, including cattail biomass and inoculum, was the same and equal to 500 g, and distilled water was added to obtain TS 5 wt.% and 10 wt.%. Total content of volatile solids in samples No 1 and No 3 before the digestion was approximately about $35 \text{ g}\cdot\text{L}^{-1}$, while in samples No 2 and No 4 – about $70 \text{ g}\cdot\text{L}^{-1}$. Comparing the previous studies of inoculum enhanced anaerobic digestion of plant biomass [14] a much less proportion of inoculum was used in the presented study, and initial VS based inoculum to substrate ratio (ISR) was equal to 0.05 for samples No 1, No 2 and 0.237 for samples No 3, No 4. The initial pH values were slightly higher for samples No 3, No 4 with a higher mass fraction of inoculum.

Table 1.2.2 - Initial parameters of suspensions of broadleaf cattail and yeast inoculums

Sample	TS (wt.%)	X_m	TS _{in} (wt.%)	VS _{tot} (g·L ⁻¹)	ISR	pH
No 1	5	0.05	0.25	35.16	0.05	7.03
No 2	10	0.05	0.5	70.31	0.05	6.76
No 3	5	0.2	1.0	34.87	0.237	7.48
No 4	10	0.2	2.0	69.74	0.237	7.42

The laboratory block of the fermentation process was carried out as follows.

The kinetics of biogas output was studied on a specially designed laboratory digestion unit (Fig. 1.2.1). The main component of the anaerobic digestion experimental unit is a thermostatic incubator TCP-01-5-BMT (1), which provides automatic constant temperature mode for 10 anaerobic reactors 2, each with nominal volume of 1 L. Reactors 2 were covered with a black polyethylene lining to prevent them from the direct sunlight. Water temperature in the incubator 1 was maintained in the range of 34±0.5°C, which corresponds to the mesophilic digestion process. Thermostatic incubator 1 has an option of periodic shaking of reactors 2 with a specified frequency.

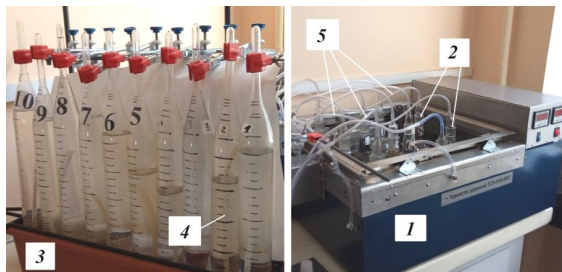

1 – thermostatic incubator; 2 – anaerobic reactors; 3 – water bath;
4 – gas-holding and measuring eudiometer flasks; 5 – biogas output tubes

Figure 1.2.1 - Experimental unit for studying the kinetics of the anaerobic digestion in the batch mode

Hermetically closed and immersed in water reactors 2 were equipped with transparent polyethylene tubes 5 to remove biogas. Due to the pressure difference biogas flowed through the tubes 5 into laboratory gas-holding and measuring glass flasks 4 with nominal volume of 500 mL. Flasks 4 were inverted upside down and immersed in a water-filled bath 3. The pH value of the water in the bath 3 was maintained below pH=5 to prevent the dissolution of CO₂ containing in the biogas, so as an inorganic carbon in water solutions at such pH is mainly in the form of carbon dioxide.

Total duration of the anaerobic digestion, carried out in batch mode, was equal to 24 days. Anaerobic reactors were shook automatically for 1 min every hour. Real-time monitoring of the biogas accumulation in the graded gas-holding eudiometer flasks 4 was done using a remote video surveillance system. Stream video from the webcam was continuously transmitted to the cloud storage, and the current values of the biogas volume were regularly recorded, allowing the continuous control over the kinetics of biogas output.

Chemical composition of biogas was measured once a day using a 5-component portative gas analyzer Dozor-5M. Four gases were monitored for the evaluation of biogas quality, namely methane CH₄, vol.%, ammonia NH₃, mg/m³, hydrogen sulphide H₂S, mg/m³, and carbon dioxide CO₂, vol.%. Fifth component was oxygen to control the anaerobic conditions inside the reactors.

Thermo-gravimetric analysis was used for the assessment of the biodegradation degree of the plant biomass in the result of anaerobic digestion. A number of previous studies confirmed the effectiveness of this method for the analysis of AD process of livestock and food wastes, roadside grass and directly of the broadleaf cattail [22].

Thermo-gravimetric studies of digestate samples of broadleaf cattail suspensions, anaerobically digested using the yeast residues inoculum, as well as the inoculum dry mass itself, were performed on a Q-1500D derivatograph of the Paulik-Paulik-Erdey system with computer recording of weight losses and thermal effects. The samples were analyzed in a dynamic mode in air with a heating rate of 5°C/min.

Combining science, education, and production as a way to form an effective mechanism for preventing climate change

The weight of the samples was 100 mg, and the reference substance was aluminium oxide Al_2O_3 .

The following results were obtained and discussed in the course of the study.

Integral curves of specific biogas yield in the process of the 24-days lab-scale anaerobic mesophilic digestion of broadleaf cattail suspensions with the yeast residues inoculum were obtained (Fig. 1.2.2). Multistage biogas yield curves were obtained, which can be explained by sequential digestion of various components of suspensions. A specific feature is a fairly active formation of biogas in all four samples in the first day of the study with the highest specific biogas output for the sample No 3 with TS= 5 wt.% and $X_{in}=0.2$. Active methanogenesis in the first day of the study can be explained by the digestion of inoculum, containing previously formed centres of biochemical reactions. After the initial stage of active methanogenesis, more or less clear horizontal sections of different duration are observed on all four curves of specific biogas yield q_{bg} (Fig. 2). This can be probably a result of the transition of digestion process from the use of inoculum in biochemical reactions, to the formation of centres of biochemical reactions in the plant substrate induced as a result of the fermentation process. The highest rate of methanogenesis and the largest total and specific biogas yields were obtained for the suspension No 4 with the dry matter content TS= 10 wt.% and mass fraction of inoculum $X_{in}= 0.2$.

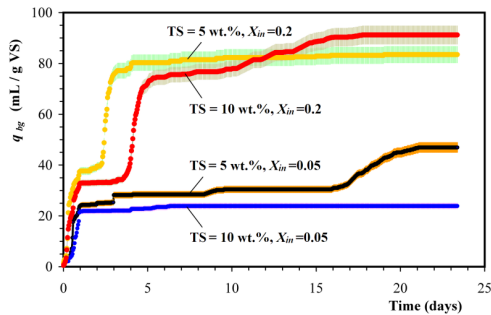

Figure 1.2.2 - Specific biogas yield in the lab-scale mesophilic anaerobic digestion of broadleaf cattail suspensions (error bars $\pm 4\%$ are specified)

Total biogas output increased with increasing both dry matter content and mass fraction of inoculum. Moreover, the effect of inoculum is much stronger, so at low inoculum content ($X_{in}=0.05$) increasing of dry matter content did not caused the increasing of total biogas output (Table 3). At the same time, with a sufficiently high content of inoculum $X_{in}=0.2$, the increase of dry matter content from 5 wt.% to 10 wt.% led to an almost proportional increasing of the biogas volume.

Specific biogas yield varied from $23.9 \text{ mL} \cdot \text{g}_{\text{VS}}^{-1}$ for the sample No 2 to $91.2 \text{ mL} \cdot \text{g}_{\text{VS}}^{-1}$ for the sample No 4. It is important that at low content of inoculum ($X_{in}=0.05$) specific biogas yield is 2.0 times higher for wet digestion process with TS=5 wt.% comparing the suspension No 2 with TS=10 wt.%. Comparing the results for the samples No 4 and No 2 with TS=10 wt.% both, it should be noted that the specific biogas output is almost proportional to the mass fraction of the inoculum, it is 3.8 times higher for the suspension with $X_{in}=0.2$ than for the suspension with $X_{in}=0.05$ (Table 1.2.3).

Average methane content in the obtained biogas varied from 29.0% for the suspension No 2 (TS= 10 wt.%, $X_{in}=0.05$) to 64.0% for the suspension No 4 (TS= 10 wt.%, $X_{in}=0.2$). Thus, dependency of the specific methane yield vs the TS content and inoculum fraction are qualitatively the same as the specific yield of biogas, only more pronounced, varying in the range from $6.9 \text{ mL}_{\text{CH}_4} \cdot \text{g}_{\text{VS}}^{-1}$ for the sample No 2 to $58.4 \text{ mL}_{\text{CH}_4} \cdot \text{g}_{\text{VS}}^{-1}$ for the sample No 4.

Table 1.2.3 - Main output parameters of mesophilic anaerobic digestion of broadleaf cattail and yeast residues inoculums

Parameter	Sample			
	No 1	No 2	No 3	No 4
Total biogas output (NL)	0.825	0.84	1.455	3.18
Specific biogas output ($\text{mL} \cdot \text{g}_{\text{TS}}^{-1}$)	33.0	16.8	58.2	63.6
Specific biogas yield ($\text{mL} \cdot \text{g}_{\text{VS}}^{-1}$)	46.9	23.9	83.5	91.2
Mean CH_4 content (vol.%)	45.0	29.0	40.0	64.0
Specific methane yield ($\text{mL}_{\text{CH}_4} \cdot \text{g}_{\text{VS}}^{-1}$)	21.1	6.9	33.4	58.4

Thus, adding of the yeast residues inoculum to broadleaf cattail suspensions increases both the total amount of biogas obtained and specific methane yield, e.g. for the suspension No 4 with total solids 10 wt.% and mass fracture of inoculum $X_{in}=0.2$ specific biomethane yield $58.4 \text{ mL}\cdot\text{g}_{\text{VS}}^{-1}$ was obtained, which is 8.5 times higher comparing the suspension No 2 with TS= 10 wt.%, $X_{in} = 0.05$. It should be noted, that obtained values are significantly less than the specific methane yield of $170 \text{ mL}\cdot\text{g}_{\text{VS}}^{-1}$, obtained for *Phragmites australis* by Ohlsson et al. [8], which can be explained by about 4 times longer duration of mesophilic digestion in the comparative study (100 days) and almost three orders of magnitude larger working volume of the digested biomass (430 L vs. 0.5 L in the current study). On the other hand, the obtained experimental results correlate well with the average actual specific yield of biomethane on the industrial methane tank of the Enzym Company, which is about $61 \text{ mL}\cdot\text{g}_{\text{VS}}^{-1}$.

The main results of the complex thermal analysis of digestate samples No 1- No 4, as well as inoculum from the digester of wastewater treatment of yeast production, obtained using a derivatograph Q-1500D of the Paulik-Paulik-Erdey system are presented in Table 1.2.4. In particular, the temperature intervals of each stage of thermal destruction of the samples and the corresponding thermal effects, as well as the temperatures of the extremes of thermal effects and the weight losses of the samples at each stage of thermal destruction are presented.

Table 1.2.4 - The results of combined thermal analysis of anaerobically digested suspensions of broadleaf cattail and yeast residues inoculums

Sample	Temperature range, °C	Weight losses, %	Thermal effect
Digestate No 1 TS = 5 wt.%, $X_{in} = 0.05$	20 – 129	4.64	endothermic, $T_{max} = 95 \text{ }^{\circ}\text{C}$
	129 – 200	7.64	endothermic
	200 – 369	41.74	exothermic, $T_{max} = 287 \text{ }^{\circ}\text{C}$
	369 – 750	32.43	exothermic, $T_{max} = 445 \text{ }^{\circ}\text{C}$
Digestate No 2 TS = 10 wt.%, $X_{in} = 0.05$	20 – 125	4.05	endothermic, $T_{max} = 98 \text{ }^{\circ}\text{C}$
	125 – 201	10.73	endothermic
	201 – 369	38.90	exothermic, $T_{max} = 300 \text{ }^{\circ}\text{C}$
	369 – 750	34.40	exothermic, $T_{max} = 457 \text{ }^{\circ}\text{C}$
Digestate No 3	20 – 134	4.92	endothermic, $T_{max} = 94 \text{ }^{\circ}\text{C}$

Combining science, education, and production as a way to form an effective mechanism for preventing climate change

TS = 5 wt.%, $X_{in} = 0.2$	134 – 185	3.11	endothermic
	185 – 355	37.73	exothermic, $T_{max} = 275$ °C
	355 – 750	34.84	exothermic, $T_{max} = 462$ °C
Digestate No 4 TS = 10 wt.%, $X_{in} = 0.2$	20 – 128	6.78	endothermic, $T_{max} = 93$ °C
	128 – 189	5.06	endothermic
	189 – 348	35.56	exothermic, $T_{max} = 275$ °C
	348 – 750	32.94	exothermic, $T_{max} = 488$ °C
Yeast residues inoculum	20 – 171	8.05	exothermic, $T_{max} = 125$ °C
	171 – 215	2.84	endothermic
	215 – 374	31.48	exothermic, $T_{max} = 278$ °C
	374 – 750	36.38	exothermic, $T_{max} = 504$ °C

Thermal destruction of digestate samples No 1 – No 4 proceeded by a similar mechanism, as follows from the similar shape of thermograms. Complete thermogram of the sample No 4 (TS= 10 wt.%, $X_{in} = 0.2$), which is the most efficient in terms of specific biogas yield, is presented in Fig. 1.2.3. Thermo-gravimetric curves (TG) show the weight losses of the samples when heated. Differential thermo-gravimetric curves (DTG) show the rate of weight losses in time, and they are the result of differentiation of TG curves. The differential thermal analysis curves (DTA) show the thermal effects of the corresponding transformations of samples.

Thermal destruction of all digestate samples occurs in four characteristic stages (Table 4). At the first stage of thermal destruction, in the temperature range of 20-134 °C, water adsorbed by the samples is released. This process is accompanied by loss of sample mass and the appearance of endothermic effects on DTA curves.

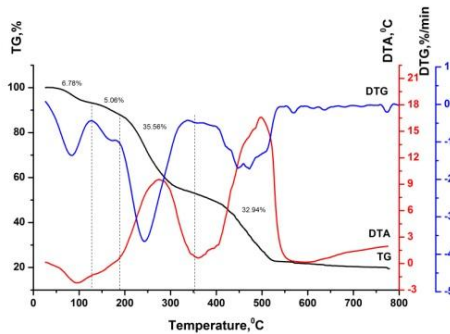

Figure 1.2.3. - Thermogram of the digestate sample No 4 (TS= 10 wt.%, $X_{in} = 0.2$)

At the second stage of thermal destruction, in the temperature range of 125-201°C, endothermic processes of dehydration of cellulose residues take place. In this temperature range there is also a partial destruction of the inoculum that is a part of the samples. It should be noted that samples with lower mass fraction of inoculum have a higher content of constitutional water bounded by cellulose. This indicates a less profound transformation of the sample components caused by the inoculum.

At the third stage, in the temperature range 185-369°C, thermo-oxidative destruction of the sample components and combustion of residues take place. This process is accompanied by intense weight losses of the samples and the appearance of strong exothermic effects on the DTA curves. It should be noted that the samples of digestate with higher content of inoculum are less thermal stable ones. Start of destructive and thermo-oxidative processes in these samples at the third stage of thermal destruction is shifted to lower temperatures. Thus, the decomposition of the digestate sample No 3 begins at temperature of 185°C, and of the sample No 4 at temperature of 189°C, while the decomposition of samples No 1 and No 2 starts at temperatures of 200°C and 201°C, respectively. In the third stage of thermal destruction, samples No 3 and No 4 lose weight more intensely, as indicated by deeper extremes on the DTG curves of these samples (Fig. 1.2.4) and the shift of the maxima of exothermic effects on the DTA curves in the region of lower temperatures (Table 1.2.4). The lower thermal stability of samples with a higher mass fraction of inoculum can be explained by the presence of a larger number of less thermally stable compounds that are the products of the biological decomposition of broadleaf cattail components during the AD process.

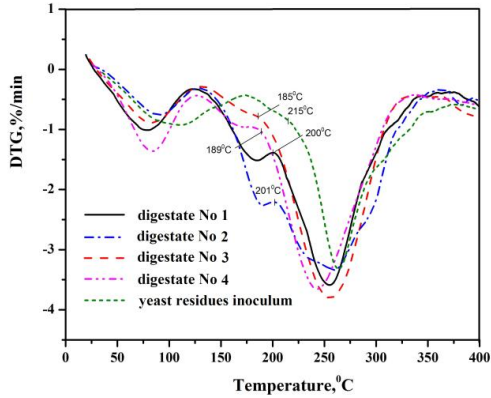

Figure 1.2.4 - DTG curves for digestate samples and inoculum sample in temperature range of 20-400 °C

It should be noted that the sample of yeast residues inoculum, in comparison with the samples of digestate No 1-No 4, has higher thermal stability. The weight losses 8.05% of the inoculum sample in the temperature range of 20-171°C, which is accompanied by an endothermic effect on the DTA curve, correspond to the release of volatile components of the sample. Low weight losses (2.84%) in the temperature range of 171-215°C correspond to the initial destructive processes in the inoculum sample. The beginning of intense weight loss of this sample is shifted to the region of higher temperatures (above 215°C). During thermal destruction in the temperature range of 215-374°C, inoculum sample loses weight less intensively (31.48%) in comparison with digestate samples No 1-No 4 (35.56-41.74%). And finally, in the temperature range of 374-750°C, the destruction of degradation residues takes place; this process corresponds to the weight losses 36.38% and the exothermic effect on the DTA curve.

The research has led to the following conclusions.

Mesophilic anaerobic digestion of broadleaf cattail suspensions enhanced by the addition of inoculum, sampled from the yeast residues anaerobic digester, was studied experimentally in a batch mode. Two-parameter experiment was realized for *Combining science, education, and production as a way to form an effective mechanism for preventing climate change*

suspensions with the total solids content TS=5 wt.% and 10 wt.% and with dry mass fractions of inoculum $X_{in}=0.05$ and 0.2. Maximum specific biogas yield $91.2 \text{ mL} \cdot \text{g}_{\text{VS}}^{-1}$ was obtained for the suspension with TS=10 wt.% and $X_{in}=0.2$. Biogas output intensified with increasing both TS content and inoculum mass fraction, and the effect of inoculum fraction was stronger. Thermo-gravimetric analysis showed the increasing of thermally unstable components in the output digestate with the increasing of the mass fraction of the yeast residues inoculum in the suspension.

REFERENCES

1. C.S. Calheiros, A.O. Rangel, P.M. Castro, Treatment of industrial wastewater with two-stage constructed wetlands planted with *Typha latifolia* and *Phragmites australis*, *Bioresour. Technol.* 100 (13) (2009) 3205–3213, <https://doi.org/10.1016/j.biortech.2009.02.017>.
2. M. Malovanyy, V. Nikiforov, O. Kharlamova, O. Synelnikov, Production of renewable energy resources via complex treatment of cyanobacteria biomass, *Chem. & Chemic. Technol.* 10 (2) (2016) 251–254, <https://doi.org/10.23939/chcht10.02.251>.
3. A. Micek, K. Józwiakowski, M. Marzec, A. Listosz, Technological reliability and efficiency of wastewater treatment in two hybrid constructed wetlands in the Roztocze National Park (Poland), *Water* 12 (12) (2020) 3435, <https://doi.org/10.3390/w12123435>.
4. W. Apollon, I. Rusyn, N. González-Gamboa, T. Kuleshova, A.I. Luna-Maldonado, J.A. Vidales-Contreras, S.K. Kamaraj, Improvement of zero waste sustainable recovery using microbial energy generation systems: A comprehensive review, *Sc. Tot. Environ.* (2022) 153055, <https://doi.org/10.1016/j.scitotenv.2022.153055>.
5. S.B. Kurniawan, A. Ahmad, N.S.M. Said, M.F. Imron, S.R.S. Abdullah, A.R. Othman, ... H.A. Hasan, Macrophytes as wastewater treatment agents: Nutrient uptake and potential of produced biomass utilization toward circular economy initiatives, *Sc. Tot. Environ.* 790 (2021) 148219, <https://doi.org/10.1016/j.scitotenv.2021.148219>.
6. S. Ghimire, L. Wang, B. Zhang, X. Li, A. Shahbazi, Production and modification of hydrochar from anaerobically digested cattail for adsorbing ammonium and phosphorous in wastewater, *Water Sc. & Technol.* 84 (7) (2021) 1678–1692, <https://doi.org/10.2166/wst.2021.378>.
7. S. Roj-Rojewski, A. Wysocka-Czubaszek, R. Czubaszek, A. Kamocki, P. Banaszuk, Anaerobic digestion of wetland biomass from conservation management for biogas production, *Biomass and Bioener.* 122 (2019) 126–132, <https://doi.org/10.1016/j.biombioe.2019.01.038>.

Combining science, education, and production as a way to form an effective mechanism for preventing climate change

8. L.O. Ohlsson, S. Karlsson, K. Rugar-Gadd, E. Albers, U. Welander, Evaluation of *Laminaria digitata* and *Phragmites australis* for biogas production and nutrient recycling, *Biomass and Bioener.* 140 (2020) 105670, <https://doi.org/10.1016/j.biombioe.2020.105670>.

9. P. Banaszuk, A.K. Kamocki, A. Wysocka-Czubaszek, R. Czubaszek, S. Roj-Rojewski, Closing the loop - Recovery of nutrients and energy from wetland biomass, *Ecol. Eng.* 143 (2020) 105643, <https://doi.org/10.1016/j.ecoleng.2019.105643>.

10. M. Malovanyy, O. Moroz, V. Popovich, M. Kopiy, I. Tymchuk, A. Sereda, G. Krusir, C. Soloviy, The perspective of using the "open biological conveyor" method for purifying landfill filtrates, *Environ. Nanotechnol. Monit. Manag.* 16 (2021) 100611, <https://doi.org/10.1016/j.enmm.2021.100611>.

11. J.F. Köbbing, F. Patuzzi, M. Baratieri, V. Beckmann, N. Thevs, S. Zerbe, Economic evaluation of common reed potential for energy production: A case study in Wuliangshuai Lake (Inner Mongolia, China), *Biomass and Bioener.* 70 (2014) 315–329, <https://doi.org/10.1016/j.biombioe.2014.08.002>.

12. A. Barco, S. Bona, M. Borin, Plant species for floating treatment wetlands: A decade of experiments in North Italy, *Sc. Tot. Environ.* 751 (2021) 141666, <https://doi.org/10.1016/j.scitotenv.2020.141666>.

13. J.J. Geurts, C. Oehmke, C. Lambertini, F. Eller, B.K. Sorrell, S.R. Mandiola, ... C. Fritz, Nutrient removal potential and biomass production by *Phragmites australis* and *Typha latifolia* on European rewetted peat and mineral soils, *Sc. Tot. Environ.* 747 (2020) 141102, <https://doi.org/10.1016/j.scitotenv.2020.141102>.

14. R. Czubaszek, A. Wysocka-Czubaszek, W. Wichtmann, P. Banaszuk, Specific methane yield of wetland biomass in dry and wet fermentation technologies, *Energies* 14 (24) (2021) 8373, <https://doi.org/10.3390/en14248373>.

15. O. Awogbemi, D.V. Von Kallon, Pretreatment techniques for agricultural waste, *Case Stud. Chem. Environ. Eng.* 6 (2022) 100229, <https://doi.org/10.1016/j.cscee.2022.100229>.

16. B. Zhang, A. Shahbazi, L. Wang, O. Diallo, The pretreatment, enzymatic hydrolysis, and fermentation of cattails from constructed wetlands, *Energy Sourc. Part A: Recov. Util. & Environ. Eff.* 35 (3) (2013) 246–252, <https://doi.org/10.1080/15567036.2010.509089>.

17. C. Catherine, M. Twizerimana, Biogas production from thermochemically pretreated sweet potato root waste, *Heliyon* 8(9) (2022) e10376, <https://doi.org/10.1016/j.heliyon.2022.e10376>.

18. M. Malovanyy, I. Voytovych, O. Mukha, V. Zhuk, I. Tymchuk, C. Soloviy, Potential of the co-digestion of the sewage sludge and plant biomass on the example of Lviv WWTP, *Ecol. Eng. & Environ. Technol.* 23 (2) (2022) 107–112, <https://doi.org/10.12912/27197050/144958>.

19. G.P.B. Marquez, H. Takeuchi, M.N.E. Montaña, T. Hasegawa, Performance of rice straw as mono-and co-feedstock of *Ulva* spp. for thalassic biogas production, *Heliyon*, 6(9) (2020) e05036,

Combining science, education, and production as a way to form an effective mechanism for preventing climate change

<https://doi.org/10.1016/j.heliyon.2020.e05036>.

20. Z.H. Hu, H.Q. Yu, Anaerobic digestion of cattail by rumen cultures, *Waste Manag.* 26 (11) (2006) 1222–1228, <https://doi.org/10.1016/j.wasman.2005.08.003>.

21. C. Nzeteu, A. Joyce, C. Thorn, K. McDonnell, S. Shirran, V. O'Flaherty, F. Abram, Resource recovery from the anaerobic digestion of food waste is underpinned by cross-kingdom microbial activities, *Bioresour. Technol. Rep.* 16, (2021) 100847, <https://doi.org/10.1016/j.biteb.2021.100847>.

22. C.I. Akor, A.I. Osman, C. Farrell, C.S. McCallum, W.J. Doran, K. Morgan, ... G.N. Sheldrake, Thermokinetic study of residual solid digestate from anaerobic digestion, *Chem. Eng. J.* 406 (2021) 127039, <https://doi.org/10.1016/j.cej.2020.127039>.

SECTION 1.3 WOOD PROCESSING BY GRANULATION TO PRODUCE BIOFUELS

**Malovanyy Myroslav
Zhuk Volodymyr
Vronska Nataliya
Oksana Liuta
Kochubei Viktoria
Tymchuk Ivan,**

Lviv Polytechnic National University

Bogachenko Galina,

International Projects Office of «KROK» University

Achieving the Sustainable Development Goals (SDGs) is a crucial task for today, especially in the area of environmental protection studies [1, 2]. In particular, the problems of wastewater treatment using natural sorbents [3] and biological objects [4], monitoring of surface water pollution [5], utilization of wastewater treatment waste at sewage treatment plants [6, 7] are important in this context. The most relevant problems of environmental safety in achieving SDGs are as follows: household waste management [8], industrial waste management [9], and environmental risk prediction [10].

A significant amount of waste is generated during wood processing [11]. Based on the data of Sustainable Agribusiness Forum (SAF) [12] up to 49 million tons of wood waste are generated annually in Ukraine, the energy of which is equivalent to 10–20 billion m³ of natural gas. This waste has been reported to cause an increase in greenhouse gases due to the decomposition of xylan (wood substances) [13], water and soil contamination in landfill areas (causing siltation of water bodies and death of aquatic inhabitants) [14, 15]. One of the most promising and long-known technologies for waste disposal, which can no longer be used in other technologies, is incineration. In this case, it is possible to solve further the important task of replenishing energy reserves while minimizing air pollution by combustion products.

*Combining science, education, and production as a way to form an effective
mechanism for preventing climate change*

The bioenergy sector can be considered to be the most dynamically developing. In 2018 the total supply of primary energy from biofuels and waste was equivalent to the replacement of 4 billion m³/year of natural gas in Ukraine [12]. In the market of biofuels the largest segment is occupied by solid biofuels in the form of firewood, wood chips, pellets and briquettes from biomass, baled straw. The share of wood biomass in the structure of energy potential of biomass in Ukraine is only about 13%, but the practical application of its potential exceeds 80% [12]. With the exacerbation of the issue of energy supply in the world, the use of wood biomass becomes especially relevant. Ukraine has a strong energy potential of biomass [16]. An important energy place among biotic waste belongs to wood biomass. But the bulk of waste, which according to various sources is up to 40% (mainly sawdust, shavings and bark), is not used for technological purposes and can be used as fuel. It is necessary to ensure relative homogeneity in terms of moisture and particle size distribution, favorable conditions for transportation, dosing, and storage of wood to use it as a fuel on an industrial scale [17, 18].

Among the most common pelleting methods [19] pelleting by extrusion method in auger - granulators must be the most promising. It is important to create pellets using a cheap binder that does not contaminate the pellet. Using of sulphate soap, the main component of which are sodium salts of fatty resin acids and salts of hydroxy acids as a product of wood decomposition, is promising binder for paper production waste [20]. The accumulation of this waste also creates a certain environmental problem, which further enhances the relevance of research. It is important that with the use of this binder the foreign products are not added into the wood, which would cause contamination of the gases - the products of pellets combustion. Therefore, the obtained product is promising for use in bioenergy.

The *aim of the research* was to establish the optimal conditions for the pine wood waste disposal by the production of pellet fuels. To obtain this aim following tasks were accomplished: to investigate the optimal parameters of the filtration drying process; to establish the optimal concentration of the sulphate soap as a binder.

Combining science, education, and production as a way to form an effective mechanism for preventing climate change

The materials and methods used in the study were as follows.

The use of wet raw materials for the producing of pellets is impractical due to the difficulty of pellets forming from wet raw materials, their low calorific value, and the inability to ensure the strength of the pellets. In addition, the reduction of the amount of moisture that evaporates during combustion improves the operating conditions of the metal elements of the oven. Due to the fact that wood waste is stored outdoors, its moisture can reach more than 70% based on dry weight. Therefore, for the further use of wood waste as a raw material for pellets production, they must be dried to moisture content below 10% based on dry weight. The process of drying wood waste was carried out by organizing the filtration flow of the coolant through a fixed layer of wood waste; the research was carried out on the installation as it is shown in Fig. 1.3.1.

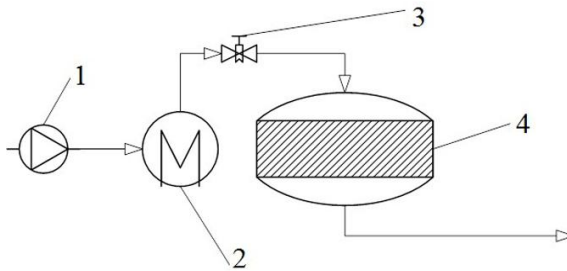

1 – fan; 2 – heater; 3 – regulating valve; 4 – drying chamber

Figure 1.3.1 - Scheme of installation for research of wood waste drying

To establish the optimal ratio between the amount of wood waste and binder the research was conducted on the installation shown in Fig. 1.3.2.

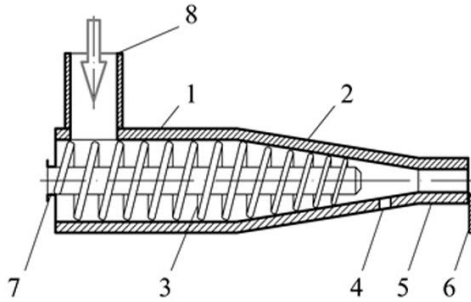

1 – cylindrical part of the housing; 2 – conical part of the housing;
 3 – auger with conveying, sealing and squeezing blades; 4 – drainage hole;
 5 – die; 6 – cutting device; 7 – reducer shaft; 8 – loading window

Figure 1.3.2 - Scheme of the installation for the formation of fuel pellets from wood waste by extrusion method

Ensuring an even distribution of components in the process of mixing binder and filler is extremely difficult due to the small amount of binder, its high viscosity and hygroscopicity of wood waste. The heterogeneity of the mixture leads to a deterioration in the quality of the pellet fuels, their fragility both in places of excess binder and its deficiency. Increasing the amount of binder leads to deterioration in the quality of the obtained pellets, in particular, reduces their strength. Equipping the conical part of the housing with drainage holes ensures that part of the liquid binder is removed from the mixture. Due to the increase in pressure in the conical part of the housing, the binder component is evenly distributed between the fine particles of wood waste, and its excess is removed through the drainage holes, which provides high strength of the obtained pellets and reduces their fragility.

Excess binder reduces friction between the mixture and the working parts of the installation, which helps to reduce the specific energy consumption of the pelleting process, as well as prolongs the service life of the equipment. Drainage holes on the conical part allow removing excess binder from the mixture. Due to the drainage holes, the excess binder is removed out and the pressure is reduced.

Waste of coniferous wood, mainly pine, from a sawmill was used as a fuel pellet base in this study. Granulometric measurements of pine sawdust revealed that

Combining science, education, and production as a way to form an effective mechanism for preventing climate change

95.1±0.5% wt. consisted of particles with sizes up to 1 mm, while 4.9±0.5% wt. consisted of particles with sizes ranging from 1 mm to 2.5 mm. To determine the optimal conditions for the creation of pellets on the first stage the mixture was prepared in a container, which was filled with filler pine sawdust and binder (the volume of the raw material mixture was the same for each time). Then these components were mixed in the preparation chamber and the dosing auger 3 (Fig. 2), then were transferred to the cylindrical 1, conical 2 part and dies 5, where the process of forming granules took place. During the formation the wood particles were compressed approaching the minimum distance from each other. And the binder wrapped them and bonded the particles together. The optimal amount of binder was determined by the pressure, which removed the excess amount of binder outside the pressed mass. All these actions were performed in order to preserve the shape of the pellet after reducing the pressure.

Sulphate soap from the pulp processing industry, composed mainly of sodium salts derived from fatty resin acids and hydroxy acids from wood decomposition, was used as a binder in this study. The experiments continued with an alternate increase in the amount of filler with a constant volume of binder, as well as with an increase in the latter and the constant volume of the former. The criterion that characterizes the optimal ratio of filler and binder is the strength of the pellets. The finished pellets were dried and tested for strength after leaving the auger, and the strongest ones were then used for subsequent experiments. The calorific value of the granules, the content of volatile components, and the coke residue in the granules were determined by the method [21]. Determination of the static strength of the granules was performed on the MII-100 device according to the method [22].

The following results were obtained and discussed in the course of the study.

In order to properly organize the technological process of drying, the influence of the heat agent speed, its temperature, and the thickness of the layer on the process of wood waste drying were investigated. Experimental research of the kinetics of the

drying forestry waste process was conducted at different temperatures of the heat agent, the results of experimental studies are provided in [20].

The first stage of drying is characterized by a sharp decrease in the moisture content of the material, and the differences in the drying rate of different thickness layers are insignificant. This is due to the fact that in the first drying period the evaporation of moisture is carried out from the surface layers and is limited by external diffusion factors and coolant characteristics, in particular the coolant temperature and the drying rate of the material. In the second stage the moisture is removed from the deeper layers of the material and there are significant differences in the different thickness layers' moisture change. For this period the drying rate decreases and is limited by molecular diffusion and moisture conductivity of the layer. Due to the fact that the first period is long the drying process can be intensified by increasing the heat agent speed or its temperature. The heat transfer coefficient increases with increasing speed, the diffusion resistance decreases, but instead the removal of wet material from the drying zone increases. This in turn increases the load on the treatment system and causes the need to re-dry the removed particles. Therefore, for the conditions of the research the optimal speed of the agent was selected, which provided high performance of the drying process with minimal loss of wet material. Experiments have shown that the most optimal velocity is $v_0 = 4.2$ m/s, at which the loss does not exceed 3.5% [23].

To analyze the optimal parameters of the drying regime of wood waste research data on the effect of drying agent temperature on the drying kinetics described in [20] were used, as well as data from own studies on the impact on the drying kinetics of the waste layer height, which were carried out on the installation described above. The results are presented in Fig. 3. Critical moisture content of wood waste (W_{cr}) was determined, which corresponds to the transition of the drying process to the second stage, as well as the drying time in the first stage. The calculated values of critical moisture for the experimental conditions are shown in Table 1.3.1.

Table 1.3.1 - Determination of critical moisture for different research conditions of wood waste drying kinetics of a waste layer

H (m)	t ($^{\circ}\text{C}$)	W_{cr} , water/dry material (kg/kg)	τ_1 (s)
For different material layer heights			
$10 \cdot 10^{-3}$	100	0.34	1,400
$20 \cdot 10^{-3}$	100	0.36	1,600
$30 \cdot 10^{-3}$	100	0.38	2,000
$40 \cdot 10^{-3}$	100	0.40	3,600
For different coolant temperatures			
$20 \cdot 10^{-3}$	135	0.34	1,100
$20 \cdot 10^{-3}$	100	0.36	1,600
$20 \cdot 10^{-3}$	80	0.39	1,900
$20 \cdot 10^{-3}$	60	0.42	2,400

where H is the material layer height; W_{cr} is the equilibrium value of moisture; τ_1 is the duration of drying in the first period

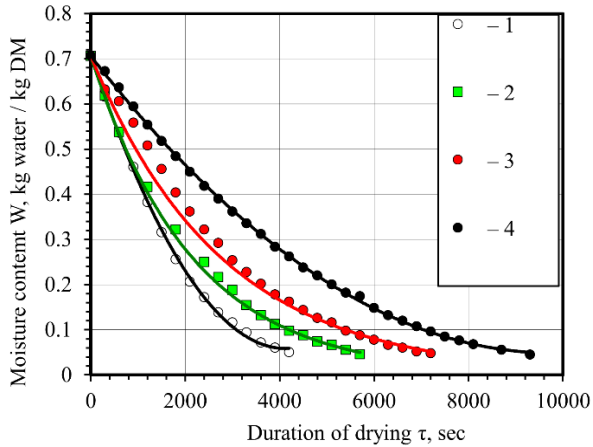

Figure 1.3.3 - Kinetics of wood waste drying for coolant temperature $t = 100\text{ }^{\circ}\text{C}$ and height of wood waste layer: 1 – $10 \cdot 10^{-3}$ m, 2 – $20 \cdot 10^{-3}$ m, 3 – $30 \cdot 10^{-3}$ m, 4 – $40 \cdot 10^{-3}$ m

The drying time in the second period τ_2 was determined by using a combined array of experimental data. The total drying time to final moisture W_{fin} was defined as the sum of drying times in the first period τ_1 and in the second period τ_2 . The

Combining science, education, and production as a way to form an effective mechanism for preventing climate change

results of experimental studies of drying wood waste in the filtration mode, as well as the results of calculations of the optimal parameters of the filtration drying process and energy costs for the drying process are shown in Table 1.3.2.

Table 1.3.2 - Selection of parameters of the wood waste drying process

H (m)	t ($^{\circ}\text{C}$)	ρ (kg/m^3)	ω_0 (m/s)	t_{fin} ($^{\circ}\text{C}$)	τ_{fin} (s)	Q_{dry} (kJ/kg) dry weigh	Q_{wet} (kJ/kg) water
For different material layer heights							
$10 \cdot 10^{-3}$	100	940	4.2	90	4,200	150,000	773,000
$20 \cdot 10^{-3}$	100	940	4.2	90	5,700	174,000	744,000
$30 \cdot 10^{-3}$	100	940	4.2	90	7,200	178,000	610,000
$40 \cdot 10^{-3}$	100	940	4.2	90	9,400	180,000	551,000
For different coolant temperatures							
0.020	135	940	4.2	125	3,900	110,000	385,000
0.020	100	940	4.2	90	5,700	174,000	744,000
0.020	80	940	4.2	70	6,800	189,000	804,000
0.020	60	940	4.2	50	7,200	194,000	876,000

where ρ is the wood waste density; ω_0 is the coolant velocity; t_{fin} is the final coolant temperature; Q_{dry} is the heat consumption for drying in terms of 1 kg of dry material; Q_{wet} is the heat consumption for drying in terms of 1 kg of evaporated moisture.

Based on own research the optimal layer thickness $20 \cdot 10^{-3}$ m, coolant temperature 135 $^{\circ}\text{C}$ and drying time 3,900 s were selected to achieve the required moisture content of the material. However, depending on the conditions of the technology organization as a whole, the selected parameters of the implementation of the drying process may differ. Therefore, the obtained results (Table 2) can be used to calculate and design the processes of drying wood waste in industrial technologies.

The determining conditions for the use of pellets are their static strength and calorific value, although important parameters are also the content of volatile components in the combustion gases of pellets and coke residue. The results of determining the statistical strength of the pellets depending on the amount of binder in the raw material mixture are shown in Fig. 1.3.4.

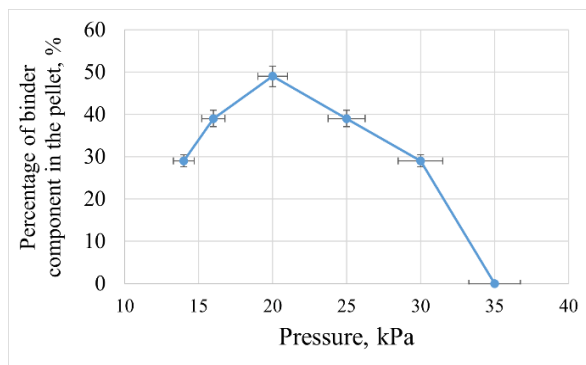

Figure 1.3.4 - Static strength test results (error bars \pm ... % for the binder's content, and \pm ... % for static strength are specified)

Analysis of the data in Fig. 4 showed that the strength of the pellet increases with increasing content in the mixture of the binder component. But at the same time, the increase in the content of this substance causes deterioration in the bonding of wood particles together, and this, in turn, leads to a decrease in static strength. The optimum concentration of binder is 20%. It should be noted that ratio of mixture and binder properties are very important to obtain final product with appropriate strength and calorific value. The average amount of binder usually is within limits of 15–25% [24] that is in line with obtained results.

Studies were conducted to establish the concentration of the binder, which would ensure the maximum calorific value of the pellet. According to the results of the experiments a graph was constructed, which is shown in Fig. 5. Analysis of the results presented in Fig. 1.3.5 shows that the main component that increases the calorific value of the pellet is the binder component. As the concentration of the binder in the pellet increases, the calorific value of the latter increases monotonically from 17.9 MJ/kg to 28.9 MJ/kg. Based on the condition of ensuring the physical stability of the pellets the optimal concentration of the binder in the pellet was chosen at the level of 20% by weight of the pellet which is consistent with research findings by Ju et al. [25].

Combining science, education, and production as a way to form an effective mechanism for preventing climate change

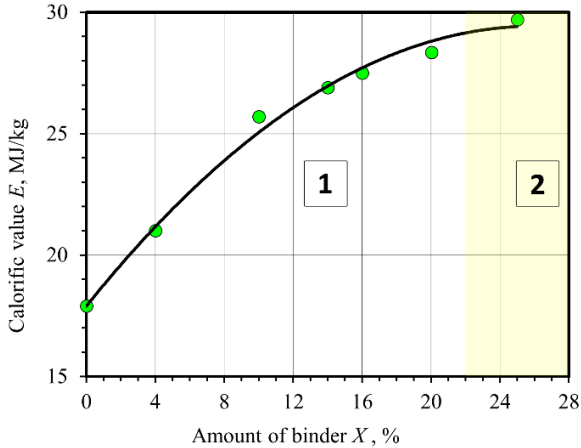

Figure 1.3.5 - Dependence of calorific value of pellets on the percentage of binder (1 – zone of plastic formation of pellet, 2 – zone of technological risk)

Studies have shown that the percentage of volatile components increases monotonically with the addition of a binder from 67.5% (binder content 0%) to 75% (binder content 20%), the dependence is close to linear. The reason for this is that sulphate soap (which is used as a binder) has a higher concentration of volatile components. Therefore, with increasing its content the number of volatile components in the granule increases. As the content of sulphate soap in the granule increases, the content of coke residue monotonically decreases from 15.9% (binder content 0%) to 10.7% (binder content 20%), the dependence is close to linear. The reason for this is the better coking ability of wood waste in the mixture compared to the binder. The same trend was observed in case of using binder for concrete production from waste [26].

Production of biofuel from wood waste by the investigated way with optimal technological parameters is relevant in achieving SDGs: SDG7 (affordable and clean energy), SDG12 (responsible consumption and production) and SDG13 (climate

action). Moreover, using of wood waste for biofuel can decrease the level of deforestation [27].

The research made it possible to draw the following conclusions/

Studies have shown that a promising method of wood waste disposal is their extrusion pelleting using as a sulphate soap as a binder of natural origin. This allowed to minimize the environmental risk of environmental pollution by wood waste as well as to obtain biofuels.

Necessary preliminary operation before wood waste pelleting is their drying to a moisture content of not less than 10%. Based on the analysis of research data on drying of wood waste in the filtration mode the values of the optimal parameters of the filtration drying process and energy costs for the drying process were obtained. The optimal thickness of the wood waste layer 20·10⁻³ m, coolant temperature 135 oC and drying time 3,900 s were chosen to achieve the required moisture content of the material.

According to the results of the conducted researches the optimal concentration of the binder was established on the level of 20%. This is due to reducing the content of coke residue; increasing the content of volatile components; higher calorific value compared to wood waste; increasing the static strength.

Based on the obtained results it can be stated that: in the case of using a binder component the pellets are formed with lower pressures, which provides the required static strength; with the addition of a binder the calorific value of the pellet increases compared to the pellet without a binder; the binder is a lubricant that reduces friction forces and therefore the energy cost of overcoming them.

REFERENCES

1. I. Yu. Ablieieva, N. Artyukhova, J. Krmela, M. Malovanyy, and D. Bereznyi, "Fluidized bed dryers in terms of minimizing environmental impact and achieving the sustainable development goals," *Drying Technology*, vol. 40, issue 8, pp. 1598–1608, 2022.
2. O. M. Mandryk, L. M. Arkhypova, A. V. Pukish, A. Zelmanovych, and K. Yakovlyuk, "Theoretical and methodological foundations of sustainable development of geosystems," *IOP Conference Series: Materials Science and Engineering*, vol. 200, 2017, Paper no. 012018.
3. V. Sabadash, J. Gumnitsky, and O. Lyuta, "Combined adsorption of the copper and chromium cations by clinoptilolite of the sokyrnytsya deposit," *Journal of Ecological Engineering*, vol. 21, no. 5, pp. 42–46, 2020.
4. K. Jozwiakowski, P. Bugajski, K. Kurek, R. Caceres, T. Siwiec, A. Jucherski, W. Czekala, and K. Kozłowski, "Technological reliability of pollutant removal in different seasons in one-stage constructed wetland system with horizontal flow operating in the moderate climate," *Separation and Purification Technology*, vol. 238, 2020, Paper no. 116439.
5. O. Kurylets, A. Helesh, V. Vasiichuk, Z. Znak, and A. Romaniv, "Coagulation treatment of effluent from milk-processing enterprises with waste FeSO_4 ," *Eastern-European Journal of Enterprise Technologies*, vol. 1, no. 1, pp. 17–23, 2022.
6. I. Tymchuk, M. Malovanyy, O. Bota, O. Shkvirko, and O. Popovych, "Biological reclamation using a sewage sludge-based substrate – A way to ensure sustainable development of urban areas," *Ecological Engineering and Environmental Technology*, vol. 23, no. 1, pp. 34–41, 2022.
7. D. Vankovych, O. Bota, M. Malovanyy, M. Odusha, I. Tymchuk, I. Sachnyk, O. Shkvirko, and V. Garasymchuk, "Assessment of the prospects of application of sewage sludge from Lviv wastewater treatment plants for the purpose of conducting the biological reclamation," *Journal of Ecological Engineering*, vol. 22, no. 2, pp. 134–143, 2021.
8. V. Popovych, J. Telak, O. Telak, M. Malovanyy, R. Yakovchuk, and N. Popovych, "Migration of hazardous components of municipal landfill leachates into the environment," *Journal of Ecological Engineering*, vol. 21, 1, pp. 52–62, 2020.
9. L. Plyatsuk, Y. Chernysh, I. Ablieieva, O. Burla, and L. Hurets, "Research into biotechnological processes of plant Snutrition stimulation by the products of phosphogypsum disposal in gas cleaning systems," *Eastern-European Journal of Enterprise Technologies*, vol. 3, nos 10-93, pp. 6–14, 2018.
10. I. Ablieieva, L. Plyatsuk, I. Roi, O. Chekh, S. Gabbassova, K. Zaitseva, and S. Lutsenko, "Study of the oil geopermeation patterns: a case study of ANSYS CFX software application for computer modeling," *Journal of Environmental Management*, vol. 287, 2021, Paper no. 112347.

Combining science, education, and production as a way to form an effective mechanism for preventing climate change

11. S. Pandey, “Wood waste utilization and associated product development from under-utilized low-quality wood and its prospects in Nepal,” *SN Appl. Sci.*, vol. 4, 2022, Paper no. 168.

12. Renewable Energy Agency (REA, Ukraine) together with COWI A/S (Denmark) in the framework of the project “Support legislative, regulatory framework for bioenergy value chains in Ukraine”, which is implemented under the EBRD/GEF Programme Ukraine: Sustainable Bioenergy Value Chain Innovations, Bioenergy policy roadmap until 2050 and action plan until 2025, 2021, [Online]. Available: https://saf.org.ua/wp-content/uploads/2021/06/D5-Roadmap_Action-Plan_EN_03-12-2021_FINAL.pdf. Accessed: April 26, 2023.

13. F. A. Ximenes, A. Kathuria, M.A. Barlaz, and A. L. Cowie “Carbon dynamics of paper, engineered wood products and bamboo in landfills: evidence from reactor studies,” *Carbon Balance Manage*, vol. 13, 2018, Paper no. 27.

14. A. Irvanian and S. O. Ravari, “Types of contamination in landfills and effects on the environment: A review study,” *IOP Conf. Series: Earth and Environmental Science*, vol. 614, 2020, Paper no. 012083.

15. R. Martínez-García, P. Jagadesh, O. Zaid, A. A. Şerbănoiu, F. J. Fraile-Fernández, J. de Prado-Gil, S. M. A. Qaidi, and C. M. Grădinaru, “The present state of the use of wood waste ash as an eco-efficient construction material: A review,” *Materials*, vol. 15, no.15, 2022, Paper no. 5349.

16. G. Geletukha and T. Zheliezna, “Prospects for bioenergy development in Ukraine: Roadmap until 2050,” *Ecological Engineering & Environmental Technology*, vol. 22, no 5, pp. 73–81, 2021.

17. V. Vandapalli and M. Sudhagar, “Wet granulation of pine wood powders,” *Transactions of the ASABE*, vol. 57, no. 4, pp. 1211–1218, 2014.

18. P. Alizadeh, L. G. Tabil, E. Mupondwa, X. Li, and D. Cree, “Technoeconomic feasibility of bioenergy production from wood sawdust,” *Energies*, vol. 16, 4, 2023, Paper no. 1914.

19. V. Masan, P. Burg, V. Visacki, an P. Ondrej, “Evaluation of fuel pellets as secondary product when pressing oil from grapevine seeds,” in *Proceedings of the International Scientific Conference on Engineering for Rural Development*, Jelgava, Latvia, May 23–25, 2018, pp. 1766–1770.

20. A. Y. Masikevych, V. M. Yaremchuk, R. Y. Bat, Y. H. Masikevych, M. S. Malovanyi, and V. M. Atamaniuk, “Utilization of wood waste by the production of fuel pellets by the extrusion method,” *Naukoviy Visnyk NLTU Ukrainy*, vol. 29, 1, pp. 93–97, 2019.

21. P. R. Shailendrasingh, V. J. Sachin, and N. T. Bhaskar, “Methods to improve properties of fuel pellets obtained from different biomass sources: Effect of biomass blends and binders,” *Fuel Processing Technology*, vol. 199, 2020, Paper no. 106255.

22. D. Verkoeijen, G. M. H. Meesters, P. H. W. Vercoulen, and B. Scarlett, “Determining granule strength as a function of moisture content,” *Powder Technology*, vol. 124, no. 3, pp. 195–200, 2002.

23. A. Masikevych, M. Kolotylo, R. Bat, Yu. Masikevych, M. Malovanyy, V. Atamaniuk, and K. Petrushka, “Wood wastes utilization of the Pokutsko-Bukovinian Carpathians in the result of introduction of improved production technology of fuel briquettes,” *Environmental Problems*, vol. 4, 1, pp. 24–31, 2019.

24. J. Jamradloedluk and C. Lertsatitthanakorn, “Influences of mixing ratios and binder types on properties of biomass pellets,” *Energy Procedia*, vol. 138. pp. 1147–1152, 2017.

25. X. Ju, K. Zhang, Z. Chen, and J. Zhou, “A method of adding binder by high-pressure spraying to improve the biomass densification,” *Polymers*, vol. 12, no. 10, 2020, Paper no 2374.

26. B. Zehra, A. Salem, S. Senesavath, S. Kashkash, and Z. Orban, “Sustainable design of concrete using industrial additives and wastes,” *Pollack Periodica*, vol. 16, 2, pp. 19–24, 2021.

27. M. M. Labat, K. Hlavčová, and G. Földes, “Estimation of changes in runoff due to changes in forest composition,” *Pollack Periodica*, vol. 14, 3, pp. 109–120, 2019.

CHAPTER 2
CLIMATE CHANGE AND
AGRICULTURE

*Combining science, education, and production as a way to form an effective
mechanism for preventing climate change*

SECTION 2.1 PECULIARITIES OF CLIMATE CHANGE IMPACT ON AGRICULTURAL ACTIVITIES

Nataliia Prokopenko

Kharkiv National Automobile and Highway University, Ukraine

Global climate change is one of the most pressing issues of our time. The world's attention is focused on its solution. Climate change is the result of a complex interaction between natural processes and human activity. The consequences of this phenomenon are manifested in an increase in the average global temperature of both the earth's surface and the oceans. This, in turn, leads to an uneven distribution of precipitation and a significant increase in the number of extreme weather events. Droughts, floods, flash floods, hurricanes, and flooding are becoming more frequent and intense.

Recent decades have seen an increase in the intensity of natural disasters, which is associated with a record increase in global temperatures. According to UN experts, climate change has led to droughts that used to occur once every 10 years now occurring 70% more often. The frequency of rainstorms has also increased - they now occur 30% more often.

Climate change has different impacts on agriculture. Direct impacts are related to changes in climate characteristics such as temperature and precipitation. Extreme weather events, such as abnormal precipitation, can cause serious impacts such as mudslides, landslides, flooding, and soil erosion. Abnormal temperatures, such as frosts, cause crops to freeze to death. Abnormal heat, in turn, reduces their productivity.

Indirect impacts are reflected in the reduced availability of water resources for various sectors of the economy, including agriculture. The intensity of precipitation and river runoff are becoming critical factors for water supply.

Combining science, education, and production as a way to form an effective mechanism for preventing climate change

Ukrainian agriculture has also suffered significant impacts from climate change. Over the past 30 years, the average annual temperature in Ukraine has risen by almost 1.5 °C. This warming is unevenly distributed over the seasons, which affects the efficiency of precipitation for agriculture. The frequency of extreme high temperatures is increasing, while the frequency of extreme cold is decreasing. This leads to prolonged heat waves, deteriorating water quality, and increased risk of fires.

Thus, the main climate threats to Ukraine's agricultural sector include

- an increase in the average annual air temperature.
- Increase in the number of days with abnormally high temperatures, which negatively affects crop and livestock production.
- Increased frequency of drought events, especially in combination with high temperatures.
- Sharp temperature fluctuations between seasons and within individual months, which reduce plant resistance.
- Increased frequency of natural weather events in the warm season.
- Reduced precipitation and its intensity, which complicates the accumulation of soil moisture.
- Increased uneven distribution of precipitation, which affects water availability.
- Lack of stable snow cover, which increases the risk of freezing of winter crops.
- favorable conditions for the spread of pests and diseases, which can reduce the productivity of major crops by 20-30%.
- Increased risk of fires, which undermines the sustainability of agroecosystems.

If the current trends in Ukraine continue in the face of future climate change, they may lead to a significant aggravation of certain problems, including

- Increased plowing of agricultural land is currently taking place across the country. This process not only increases the area of cultivated land, but also

Combining science, education, and production as a way to form an effective mechanism for preventing climate change

negatively affects the ecological state of the regions, and in the future, against the background of climate change, the negative consequences of this process may increase.

- Monocultivation of agricultural production is becoming more pronounced. Growing industrial and oilseed crops, although requiring fewer resources, increases the environmental burden on the land, which can have long-term negative consequences for soils.

- there is a constant increase in the need for large capital investments. The introduction of innovative crop cultivation technologies and the introduction of new crop species requires and will continue to require significant financial resources. These investments are necessary to increase the resource potential of ecosystems and ensure the country's food security.

- Competition between agricultural producers is constantly increasing. This competition is directly dependent on land fertility and access to water resources, especially in areas of insufficient natural moisture.

Global and regional climate change will have serious implications for Ukraine's agricultural sector. These impacts are manifested in the following:

- The growing areas for some crops are shifting to the north. For example, sugar beets and soybeans have already moved 150 km from south to north. This leads to an increase in the growing season and the formation of a new agroclimatic zone in southern Ukraine;

- the location of relevant infrastructure is shifting. Storage and primary processing of agricultural products are being adapted to new climatic conditions. This requires changes in the development of infrastructure that meets new regional growing conditions;

- there is a decrease in agricultural productivity. The lack of innovative resource-saving technologies and equipment can significantly reduce production efficiency in the face of rapid climate change;

Combining science, education, and production as a way to form an effective mechanism for preventing climate change

- soil degradation processes are intensifying. The spread of droughts leads to a loss of soil fertility, which threatens to reduce yields;

- the problem of changing the structure of crop production is becoming more urgent. The introduction of drought-tolerant crop varieties and the abandonment of water-loving crops is a necessary step due to the threat of increased access to water resources;

- the risk of plant damage by diseases and pests is increasing. Climate change creates favorable conditions for the active development of pathogens, which can lead to significant losses in agriculture⁴

- there is a gradual decline in the production of traditional fodder crops. There is a need to grow non-traditional crops, such as sorghum or triticale, to meet the needs of livestock;

- the existing systems for maintaining the microclimate in livestock buildings are becoming unsuitable. New climate conditions require adaptation of these systems to ensure comfortable conditions for animals.

It should be noted that climate change can be viewed not only as a set of certain limitations and difficult conditions for the existence and development of the agricultural sector, but also as a set of key opportunities that are opening up for this sector in Ukraine. These opportunities include the following:

- growing new crops is becoming a reality. Climate change allows to expand the range of agricultural products produced in Ukraine and increase export opportunities. The growth of the average annual thermal period contributes to an increase in agricultural production within one year;

- the lengthening of the growing season opens up new opportunities for winter grain crops. The northern regions of Ukraine get a chance to effectively introduce late-ripening varieties and hybrids that require more heat. Wintering conditions for crops and perennial grasses are also improving;

- there is a demand for the latest irrigation technologies. There is a growing need for sprinkler technology and equipment designed for different scales of consumers - from large agricultural holdings to individual farms;

- development of new areas of scientific research becomes a priority. The creation of intensive crop cultivation technologies and innovative soil cultivation systems will take into account the specific features of the regions.

Thus, climate change poses both challenges and opportunities for Ukraine's agricultural sector. And the main task of both scientists and farmers is to adapt to these conditions in order to ensure sustainable and efficient agricultural production under the new climate regime.

To date, some environmental and agricultural problems have been identified that are particularly relevant in the context of climate change.

Such problems include the spread of diseases and pests in agriculture, which is caused by climate change. This problem can manifest itself in different ways:

- First, crop pests and diseases may become resistant to existing plant protection products. This leads to a significant expansion of their range, an increase in the number and number of generations. New types of diseases and quarantine facilities are emerging, making it more difficult to control them;

- Second, changes in local climatic conditions create a favorable environment for the development of vectors of vector-borne diseases. As a result, the number of infectious diseases among animals is growing, which is a serious threat to the agricultural sector.

It is important to note that animals are extremely sensitive to prolonged exposure to high temperatures. If the ambient temperature exceeds 25 °C, animals become less active, consume less feed and are constantly thirsty. Prolonged exposure to such conditions causes heat stress, which negatively affects their immune system and contributes to the development of various diseases, including gastrointestinal disorders and pneumonia.

Equally important is the threat of the spread of new diseases among animals. There is a fairly high probability of outbreaks of diseases such as contagious nodular dermatitis, West Nile fever, bluetongue, borreliosis, and Crimean-Congo hemorrhagic fever. Tick infestation is also on the rise, which can lead to weight loss of up to 18-20%. The spread of exotic infections, increased frequency and duration of avian influenza, African and classical swine fever, rabies, leptospirosis, and tularemia are also becoming a serious threat to the effective functioning of the livestock sector.

In addition, climate change has a negative impact on fish health and water productivity. An increase in water temperature in fisheries reservoirs can lead to an expansion of the species spectrum of invasive diseases that were previously found only in countries with warm climates. Changes in water quality will lead to the emergence or intensification of dangerous infectious and invasive fish diseases, such as rubella, carp pox, and gill necrosis.

It is also important to consider the threat of the spread of aggressive alien species. For example, ragweed, the Colorado potato beetle, and Sosnovsky's hogweed cause significant losses in biodiversity and economic value of ecosystems exposed to biological invasions, which leads to serious economic losses and poses a threat to human health.

Climate change is causing serious damage to agriculture, but it is also setting the direction for the future development of this sector of the economy. Today, it is necessary to develop the potential of public-private partnerships in the agricultural sector. Cluster initiatives and other forms of cooperation between the state and agribusiness can become effective tools for introducing innovative technologies into climate change-adapted agricultural production. Such a partnership will facilitate the joint use of the state's natural resource potential and the financial capabilities of agribusiness.

The International Organization for Agriculture and Food (FAO) is also actively implementing a strategic plan for adapting agri-food systems to climate change.

Combining science, education, and production as a way to form an effective mechanism for preventing climate change

The main focus is on reorienting agri-food systems towards innovative and carbon-neutral agribusiness. This includes the introduction of climate-smart technologies that reduce greenhouse gas emissions, adapt to new climatic conditions, and increase agricultural production.

The World Bank defines climate-smart agriculture as a comprehensive approach to managing agricultural systems. This approach is aimed at increasing productivity, adapting to climate change, reducing greenhouse gas emissions, and increasing farmers' incomes. Internationally, it is recognized that global climate change poses a serious threat to the sustainable development of agribusiness, increasing the risks of crop loss and reducing its profitability. It also has a negative impact on food security.

Today, the following priority areas for the development of climate-oriented agriculture are identified.

1. Organic farming. The development of organic agriculture is a key area in the medium-term “green transformation” of the agricultural sector. Organic production plays an important role in climate change adaptation and mitigation. In the EU, the demand for organic products is growing, outstripping domestic production capacity. Today, organic products account for about 2% of total EU agri-food imports, and this figure is growing.

2. Circular bioeconomy. Preventing food waste and losses is a priority for the circular economy. At the same time, this is aimed at achieving the 12th Sustainable Development Goal, which provides for the transition to rational consumption and production models. The main mechanisms for minimizing food waste and losses include the introduction of economic instruments that encourage the use of waste biomass for the production of biofuels, electricity and heat. It is also necessary to introduce mechanisms for providing subsidies for the collection and transportation of plant waste that is suitable for animal feed production.

3. Bioenergy. Ukraine has a significant potential for biomass energy production, which could replace about 11% of natural gas and 19% of electricity

Combining science, education, and production as a way to form an effective mechanism for preventing climate change

needs. Waste and by-products of agricultural and food production are available and cheap, making bioenergy production economically viable. The use of biomass increases the country's energy security, reduces energy costs, and generates additional income for producers. It also reduces greenhouse gas emissions, estimated at 8.2 million tons of CO₂ equivalent.

4. Introduction of modern irrigation technologies. The modernization of agriculture in areas with insufficient natural moisture should be based on an assessment of the technical condition of irrigation systems, restoration and modernization of these systems. It is necessary to determine the priority of system rehabilitation and the amount of funding. Also important is the construction of modular pumping stations to ensure the operation of irrigation systems, as well as government support and loans for the restoration of irrigation systems and the purchase of necessary equipment.

5. Biological mechanisms to reduce the sensitivity of agroecosystems to climate change. Scientists at the Institute of Climate-Smart Agriculture of the National Academy of Agrarian Sciences have developed and scientifically substantiated approaches to adaptation of agroecosystems. In particular, they have found a positive impact of legumes on soil conditions, including a reduction in the load of chemicals and an increase in soil nitrogen levels. This helps to reduce the negative impact of climate change on agricultural production.

6. Development of farming systems with resource-saving elements. Scientists have developed ways to sequester and store carbon in soils, which helps mitigate the negative impact of climate change. These measures are aimed at increasing fertility and reducing CO₂ emissions, which will help achieve carbon neutrality in the agricultural sector. The implementation of these developments will increase the organic matter content in soils by 10% and more.

7. Improving plant protection systems. The use of biological products and environmentally friendly pesticides helps protect plants from pests and diseases. This

not only prevents crop losses but also improves plant resistance to extreme weather conditions.

8. Use of adapted varieties and hybrids. Scientific research has shown that the extended period of the autumn growing season requires shifting the sowing dates of winter crops by 13-15 days later. Domestic breeders have created new varieties of wheat and barley with increased winter hardiness and a short vernalization period.

9. Implementation of environmentally friendly agriculture. Scientists have developed resource-saving technologies for growing winter crops, soybeans, and corn, which can increase profitability by 10-20% depending on the crop. These technologies are based on the use of modern high-yielding varieties, growth stimulants, water-saving irrigation regimes and biological products.

10. Preventing soil degradation. Science-based land use models have been developed to preserve soil fertility and prevent soil degradation. These models take into account climate change and are based on the principles of crop rotation, basic tillage systems and irrigation technologies.

11. Expansion of climate zones. Climate variability poses threats to agriculture, so forecasting production growth requires caution. Socio-economic factors such as land degradation and the resource potential of the territories should be taken into account.

12. Adaptation and strengthening of resilience to climate change. Adaptation measures, such as soil and water conservation, the introduction of drought-resistant plant varieties, and the development of irrigation, are essential for food security.

Thus, it can be concluded that ensuring climate-smart agricultural development is important for mitigating climate change risks. This will allow Ukraine to join global efforts to combat climate change and adapt the agricultural sector to new natural and climatic conditions.

REFERENCES

1. Prospects for the development of the agrarian sector of Ukraine in the context of climate change: analytical report / [V. Rusan, L. Zhurakovska, Y. Zhalilo, et al.
2. Shevchenko O.V. Impact of climate change on agricultural land use in Ukraine // Balanced nature management. - 2023. - №4. - C. 108-114

SECTION 2.2 INCREASING ARIDITY OF THE GROWING SEASON - CHALLENGES FOR FARMERS IN TERNOPIL REGION

Shuvar Antin

Senyk Ivan

Shmanko Nazar

West Ukrainian National University, Ukraine

Krasyuk Liudmyla

Institute of Agriculture of the National Academy of Sciences of Ukraine

Feshchenko Vasyl

Agricultural production, both on a global scale and in Ukraine, is characterized by an inextricable link with weather conditions. This factor is extremely important for our country, as agriculture plays a key role in its economy [1, 9].

The relevance of this issue is due to the fact that 50% of the harvest level is determined by the weather conditions of the growing season, primarily by temperature and precipitation. [2, 10].

It should be noted that the weather factor in agriculture is unregulated and can only be predicted and to some extent adapted to the new realities of today [8].

A characteristic feature of agricultural production both in the world in general and in Ukraine in particular, from the end of the twentieth and beginning of the twenty-first century, is that it takes place in the context of climate change, which is accompanied by an increase in the frequency of temperature maximums, days, a decrease in precipitation and their uneven distribution during the growing season [3-7].

Combining science, education, and production as a way to form an effective mechanism for preventing climate change

Therefore, it is extremely important for agriculture to study the issue of climate change in order to improve existing and develop new technological measures adapted to the realities of today's production.

The materials for this study are based on the data of the Sectoral State Archive of Hydrometeorological Observations of the State Emergency Service of Ukraine.

According to the existing classification, a very severe drought is characterized by precipitation during the growing season of less than 50% of the norm and a very significant (3.8%) excess of air temperature. A severe drought is characterized by precipitation of 70% of the norm and an air temperature 2.3% higher than the norm.

After analyzing the results of meteorological observations for 1951-2018, the months and years with very severe and severe drought were identified (Table 2.2.1).

Table 2.2.1 - Distribution of months and years by aridity

Months	Very severe drought	Severe drought
	years	
April	1952, 1957, 1961, 1973, 1984, 1994, 2004, 2007, 2011	1962, 1966, 1968, 2009, 2014, 2018
May	1986, 2011	1958, 1969, 1979, 1982, 1985, 2001, 2002, 2003,
June	1963,1964,2003, 2008, 2014	1953, 1956, 1957, 1961, 1968, 1987, 2007, 2015
July	1970, 1994, 1995, 2005, 2009, 2015	1951, 1953, 1957, 1960, 1963, 1970, 1992, 1999, 2002, 2006, 2014, 2016
August	2000, 2003, 2009, 2013, 2015	1954,1990, 1994, 1998, 2008, 2016
September	1961,1963, 1975, 1979, 1982, 2005, 2006, 2009, 2011, 2014	1951, 1967, 1981, 1983, 1984, 2018
October	1953, 1961, 1963, 1964, 1978, 1982, 2001, 2013, 2014	1982, 1990, 1995, 2000, 2004, 2017

According to the results of long-term observations (1951-2018), the number of years with very dry April was 9, May - 2, June - 5, July - 6, August - 5, September - 10, October - 8.

The number of years with severe drought in April was 6, May - 8, June - 8, July - 12, August - 6, September - 6, October - 6.

The analysis of adverse weather conditions in terms of the growing season shows that the largest number of very severe droughts was recorded in the spring (April) and autumn (September and October). This time coincides with the sowing of early spring and winter crops, and the moisture deficit creates unfavorable conditions for seed germination and seedling formation.

Severe drought is observed in late spring (May) and summer (July, August), which coincides with the generative period of crop growth and development and can negatively affect their productivity.

For a more objective assessment of climate change in the context of aridity, the percentage of years with dry months to the total number of years taken for the study was determined. The results of the analysis indicate a significantly higher proportion of dry years in the period from 1991 to 2018 (27 years) compared to the time period 1951-1990 (40 years) (Table 2.2.2).

Table 2.2.2 - Dryness of the growing season

Months	Time periods					
	1951–1990			1991–2018		
	years					
	number			number		
	Total	very arid	arid	Total	very arid	arid
April	49	5	3	49	4	3
May		1	5		1	3
June		2	6		3	2
July		1	6		5	6
August		–	2		5	4
September		5	5		5	1
October		6	2		3	4
Together		20	29		26	23

Thus, in the period 1951-1990, the number of months with very severe drought was 20, and with severe drought - 29. The time period from 1991-2018 was characterized by an increase in the number of months with very severe and severe drought - 26 cases.

Thus, the analysis of agrometeorological indicators for 1881-2018 suggests that climate change on a global scale is also reflected in the Western Forest-Steppe, in particular in the Ternopil region. At both the global and local levels, there is an increased temperature regime, decreased moisture supply during the growing season, and increased aridity. All this encourages agricultural producers to rethink existing crop cultivation technologies and adapt them to the new realities of climate change.

REFERENCES

1. Butko V.A. The impact of climate change on the product orientation of agricultural enterprises in Polissya. *Ekonomika Ukrainy*. 2014. Vol. 10(635). P. 44-50 [\[in Ukrainian\]](#).
2. Grigoriv Y. Enchanted Spring. Movement towards the desert - perspectives in spring. *Zerno*. 2019. No. 1 (154). P. 71-76 [\[in Ukrainian\]](#).
3. Kaminskyi V.F. Materials to the report of the Director of the National Research Center "Institute of Agriculture of the National Academy of Sciences of Ukraine" on the topic "Scientific basis for optimization of modern farming systems in the context of climate change". 2021. URL: <http://zemlerobstvo.com/?p=5829> [\[in Ukrainian\]](#).
4. Kaminskyi VF, Sayko V.F. Agriculture of the XXI century. Problems and solutions. *Agriculture*. 2015. Issue 2. P. 3-11 [\[in Ukrainian\]](#).
5. Lipinsky V.M., Dyachuk V.A., Babichenko V.M. Climate of Ukraine. Raevsky Publishing House, Kyiv. 2003. 342 p. [\[in Ukrainian\]](#).
6. Lipynskiy V.M., Osadchyi V.I., Babichenko V.M. Natural meteorological phenomena on the territory of Ukraine for the last twenty years (1986-2005). Kyiv: Nika-Center. 2006. 312 p. [\[in Ukrainian\]](#).
7. Osadchyi V. I., Babichenko V. M. Dynamics of meteorological natural phenomena in Ukraine. *Ukrainian Geographical Journal*. 2012. № 4. P. 8-14 [\[in Ukrainian\]](#).
8. Sayko V.F. Agriculture in the context of climate change. Collection of scientific papers of the National Scientific Center "Institute of Agriculture of the UAAS" Kyiv: ECMO Publishing House, Special issue. 2008. P. 3-14 [\[in Ukrainian\]](#).
9. Udova L.O., Prokopenko K.O., Didkovska L.I. Impact of climate change on the development of agricultural production. *Economics and forecasting*. 2014. №3. P. 107-120 [\[in Ukrainian\]](#).
10. Tarariko O. H. SWOT-analiz i analiz prohalyn (GAP-analiz) polityk, prohram, planiv i zakonodavchyykh aktiv u haluzi silskoho hospodarstva ta pidhotovka rekomendatsii shchodo yikh udoskonalennia vidpovidno do polozhen Konventsii Rio. Kherson: FOP Hrin D. S., 2016. 102 p. [\[in Ukrainian\]](#).

SECTION 2.3 CLIMATE CHANGE AND AGRICULTURE

Darejan Jashi

Nunu Nakashidze

Batumi Shota Rustaveli State University, Georgia

Agriculture, as an ancient branch, has an active contact with nature and natural resources even before the beginning of cultural farming; water is the most important of them. Today's world's attention is focused on the quantitative and qualitative indicator of water, which is due to its excessive demand. In agriculture, where a significant part of water is used for irrigation, special attention is paid to studying the ecological condition of water.

The 17th goal from the Sustainable Development Goals considers the continuous supply of clean and quality water to the population, which is a priority issue for any country. Water scarcity, poor water quality and inadequate sanitation negatively impact food security and human health. Many impurities can be found in the water, which have an adverse effect on our health.

Climate change is an identifiable change over a long period of time, including changes in statistical indicators. Climate change can be caused by both natural internal processes and external influences. For example, with volcanic eruptions, the strength of the solar cycle, long-term anthropogenic effects and changes in the composition of the atmosphere or land use. Today, the current term "climate change" refers to anthropogenic climate change.

Climate is the average of these elements over a relatively long period of time. Climate change is caused by the emission of greenhouse gases and, therefore, the increase in the concentration of greenhouse gases in the atmosphere, which prevents the reflection of heat from the earth's surface and increases the "greenhouse effect". Since the industrial revolution, as a result of human activities, an unprecedented amount of greenhouse gases has been released into the atmosphere, therefore, their

Combining science, education, and production as a way to form an effective mechanism for preventing climate change

concentration is increasing, the climate change of the atmosphere and the ecological state of the environment are changing, and the "greenhouse effect" is strengthening. Since 2011, climate change has been consistently named by the World Economic Forum as one of the top five global threats, and is "worsening much faster than expected." Climate change has direct impacts on humans and ecosystems, as highlighted in several reports of the Intergovernmental Panel on Climate Change (IPCC). As for Georgia, the negative effects of climate change are already visible in Georgia, and a trend can be observed in relation to a number of results [2,3,5]. Greenhouse gas emissions in Georgia are carried out from energy, construction, industry, transport, waste management and agriculture sectors. Among the greenhouse gases, it is worth noting the concentration of carbon dioxide, methane and nitrogen oxides, as well as synthesized "greenhouse gases". In the "2021-2027 strategy of agriculture and rural development of Georgia" it is mentioned that the further development of agriculture should be carried out in accordance with climate change and attention is focused on the introduction and implementation of climate-wise agricultural practices [1,4,5,].

The aim of the work was to study the ecological condition of the rivers of high mountainopus Ajara in order to find out how much these rivers are polluted by harmful and heavy metals in the environment. The mentioned toxicants can get into the waters by using chemical means - mineral fertilizers, pesticides, herbicides, insecticides and others, without taking into account the observance of their norms and application deadlines.

Water samples were taken for analysis from 5 locations of the Ajara region: village of Chvana (Shuakhevi municipality) - Tskaro water; Chvani water (Shuakhevi Municipality); Kokotauri village (Daba Qeda, Tshkomery community) - Kokotauri river water; From the center of the Daba Qeda - the river Ajaristskal; from the Merisi community in th municipality of Qeda – Water from the River Merisi.

A multi-element analysis was carried out, i.e. the concentration of macro and micro elements in water samples was determined with a plasma atomic emission spectrometer on the ICPE-9820 device [7, 8, 9].

The content of macronutrients is presented in Table 2.3.1. Based on the results of the analysis, the following is established:

- aluminum content in the amount of 0.672 mg/l was recorded in the water of Merisi River and it exceeds the maximum allowable concentration (0.5 mg/l);
- macroelements according to content are arranged in a row: Cs>Na>Mg, Si;
- Kokotauri river water did not contain sodium;
- iron content was recorded in Kokotauri River (0.00497 mg/l) and Merisi River (0.11 mg/l);
- it should be especially noted the content of phosphorus (0.0538 mg/l) in the water of the Merisi River, which is an indicator of its pollution (most likely due to the influence of anthropogenic factors);

Table 2.3.1 - Content of macroelements in waters by plasma atomic emission spectrometer, mg/l

Location	Al	Ca	K	Mg	Na	P	Si	Fe
1. Spring water of the village Chvana	-	20,3	-	4,75	8,22	-	4,69	-
2. Chvanis Tskali	-	69,4	-	3,81	4,22	0,0069	3,75	-
3. River Kokotauri	-	41,8	-	1,22	-	-	2,32	0,0497
4. River Ajaristskali	-	83,5	-	3,89	8,91	-	3,66	-
5. Water of Merisi River	0,672	69,1	-	2,23	3,26	0,0538	2,88	0,11
Threshold allowable concentration	0,5	-	-	-	-	0,028	10,0	0,3

The content of micro elements in the research waters is presented in Table 2.3.2. According to the results of the analysis, the following was observed:

- arsenic content was recorded only in Chvani water (0.0024 mg/l), but its concentration does not exceed the standard limit (0.005 mg/l);

Combining science, education, and production as a way to form an effective mechanism for preventing climate change

- barium and manganese are contained in the waters of Kokotauri River and Merisi River, but the content of these elements does not exceed threshold allowable concentration;

- heavy metals - titanium and vanadium were observed in the water samples taken from all locations, but, fortunately, their concentrations are less than threshold allowable concentration;

- as for mercury, the content of this toxic heavy metal in the river os Achariskali sample, it exceeded 0.0507 threshold allowable concentration which is a very alarming fact;

- it is particularly noteworthy that the content of lithium exceeds the limit of allowed concentration (0.03 mg/l) in the water samples taken from all locations;

Table 2.3.2 - Content of macro elements in water by plasma atomic emission spectrometer, mg/l

Location	As	Hg	Ba	Mn	Ti	Li	V
1. Village Chvana, Spring water	-	-	-	-	0.0378	0.667	0.0472
2. Chvanis Tskali	0.0024	-	-	-	0.0372	0.393	0.0615
3. River Kokotauri	-	-	0.0007	0.0016	0.0486	0.524	0.0559
4. River Ajaristskali	-	0.00507	-	-	0,0442	0,284	0,0750
5. Water of Merisi River	-	-	0,0025	0.0005	0.0505	0.467	0,0632
6. Threshold allowable concentration	0.005	0,0005	0,1	0,1	0.1	0,03	0,01

Climate change has a significant impact on the ecological state of the environment. Excessive rainfall, temperature changes and other extreme events have a certain impact on the mineral composition of waters and the ecological condition of the environment, and the unsystematic use of chemicals is also important, which leads to an increase in the concentration of harmful substances in water bodies and soils. The content of heavy metals in the considered research objects does not represent an alarming value, but does not allow us to relax our attention. In order to create and maintain a healthy ecological situation of the environment, it is important

Combining science, education, and production as a way to form an effective mechanism for preventing climate change

for the persons employed in the agricultural sector, farmers to take into account the local climatic conditions and conduct their activities in accordance with climate change when using the means used for agricultural production.

REFERENCES

1. Climate Change Strategy of Ajara. Report, Tbilisi, 2013, pp-364;
2. The Third National Communication of Georgia on Climate Change, Ministry of Environment and Natural Resources Protection of Georgia. Tbilisi, 2015, pp-90;
3. Margvelashvili M., Inashvili M., Mahgalashvili a., Janelidze P., Mukhigulishvili G., Lazriev A., Sikharulidze A., Shvangiradze M., Elashvili M., "Climate Change and Sustainable Development", lecture course, Ilia State University, Institute of Energy and Sustainable Development, 2016, pp-186;
4. 2030 Climate Change Strategy of Georgia (mitigation part), Government of Georgia, 2021, pp-158;
5. Sanikidze T., Aladashvili T., "Resistant to Climate Change, Low-emission (climate-smart) Agriculture", 2020, pp-82;
6. LEPL. Legislative Periodical of Georgia 2195792. Technical Regulations;
7. Order of the Minister of Labor, Health and Social Protection of Georgia No. 297/N, August 16, 2001, Tbilisi;
8. IPCC: Climate Change 2023. The Physical Science Basis. Working Group I Contribution to the Assessments Report of the IPCC. www.ipcc.ch/report/ar/wg/;
9. Thompson M. Walsh D.N. A Guide to Inductively Coupled Plasma Spectrometric Analysis. -Moscow: Nedra, 1988. – p-288;
10. Rules for protection of surface waters of Georgia from pollution. Approved by Order No. 130 of the Minister of Environment and Natural Resources Protection of Georgia dated September 17, 1996 <https://matsne.gov.ge/ka/document/view/2187528?publication=0>;

SECTION 2.4 AGRICULTURE IN THE CONTEXT OF GLOBAL CLIMATE CHANGE: REALITIES AND PROSPECTS

Shuvar Ivan,

Shuvar Bohdan,

Lviv National University of Environmental Management, Ukraine

Shuvar Antin Mykhailovych,

West Ukrainian National University, Ukraine

Agriculture is a sector of the economy that is particularly dependent on weather conditions. Climate change is affecting and will continue to affect the way we farm, and adaptation to rising temperatures is necessary to maintain farm profitability and, above all, the continued production of food and raw materials for the processing industry. In the case of agriculture, many methods that increase the resilience of farms to the effects of rising global temperatures (adaptation) can simultaneously reduce greenhouse gas emissions (mitigation) and create additional benefits in the form of increased grain yields.

Global warming is one of the most common concepts in the context of climate change. It means a steady increase in the average global air temperature over a certain period of observation. The main reason for the acceleration of these changes is human activity, which has led to significant warming of the land, oceans and atmosphere.

Climate change is already having and will continue to have a significant negative impact on agriculture in Europe in the 21st century due to increased temperatures, drought, floods, plant pests, diseases and soil degradation:

- significant losses in agricultural production (lower yields):
- reduction in the area of land suitable for growing crops.

Combining science, education, and production as a way to form an effective mechanism for preventing climate change

The regions of southern Europe will suffer the most from high temperatures and water shortages. In Northern Europe, higher temperatures may create conditions for heat-loving crops in new areas, but this will not compensate for losses in other regions.

Insufficiently science-based land use changes have a negative impact on climate change. While limiting climate change is crucial for agriculture, unfortunately, it is increasingly exacerbating the problem. In recent decades, greenhouse gas emissions (especially methane, CH₄, and nitrogen oxide, N₂O) associated with agricultural activities have been growing rapidly, contributing to the greenhouse effect and global warming. On a global scale, the main reasons are the increase in the number of ruminants (cows, sheep, etc.), as well as the expansion of arable land and pastures at the expense of forests and grasslands due to the growth of livestock, population and, above all, animals to be fed. The increase in demand for agricultural land is partially offset by an increase in crop productivity, resulting from, among other things, the use of more advanced mechanization. However, in recent decades, many regions of the world have experienced declining or stagnant yields.

Global warming, droughts and changing weather patterns have serious implications for global food production. Each degree of temperature increase means a 6% decrease in global wheat yields, a 3% decrease in rice and soybean yields, and a 7% decrease in corn yields [1]. Agricultural production in some regions may increase, but agriculture in others will suffer severely - for example, in West Africa, a 1.5°C warming leads to a 25% decrease in wheat yields, and even a 42% decrease with a 2°C warming.

The main cause of global warming is human activity - the average global temperature is now statistically almost 1.1 degrees higher than before the so-called industrial era. It was then that technological development first began to have such a significant impact on accelerating climate change. Currently, the impact of human activity (industry, transportation and agriculture) on the natural environment has

Combining science, education, and production as a way to form an effective mechanism for preventing climate change

tangible consequences, which draws attention to the need to apply the principles of sustainable development.

In recent years, the issue of global warming has become a serious problem and challenge for the entire world - and this means not only an increase in air temperature. The climate sends us ever clearer signals and provides information that proves the need to take decisive steps to stop (at least slow down!) the negative processes.

The transformation of natural areas into agricultural land involves the direct release of CO₂ as a result of decomposition/combustion of plants growing in these areas and from disturbed soil, and can reduce the absorption of both CO₂, CH₄ and N₂O. This is the result of replacing multispecies ecosystems that effectively “absorb” CO₂ from the atmosphere with monocultures, which often consist of annual plants, as well as drying/destroying the soil, applying fertilizers and plant protection products, etc. Therefore, agricultural land, along with water bodies and land plots (e.g., marshes), is one of the main sources of greenhouse gases, in addition to CO₂. However, there are many agricultural practices that can at least partially offset these emissions [2-3].

A significant amount of plant and soil emissions neutralize the potential increase in absorption due to CO₂, and limited uptake of nutrients such as nitrogen and phosphorus leads to a slowdown in plant growth and carbon accumulation rates by almost 65%. In addition, the response of plants and soil organic carbon pools to increased atmospheric CO₂ and climate change is not supported by observations. With this level of uncertainty, agricultural practices can help tip the scales in one direction, or at least help offset emissions from the food system that cannot be completely eliminated for obvious reasons, while increasing farm resilience to climate change.

The visible and tangible consequences of global warming for wildlife include a number of aspects: melting of natural ice sheets and glaciers, sea level rise, increased frequency and intensity of extreme weather events (prolonged heat, sudden rains and

Combining science, education, and production as a way to form an effective mechanism for preventing climate change

storms, severe hurricanes, etc.), disruption of the water cycle in nature (droughts and floods, including flash floods), lengthening of the growing season of flora, stepping of areas previously covered by ordinary vegetation, increased frequency and spread of forest fires, changes in the range of distribution of flora species (in particular, invasion of vulnerable and dangerous plants for sustainable diversity) and fauna, including pests and vectors of infectious diseases. Confirmation and disclosure of the peculiarities of these processes are described in publications by scientists from different countries [3], as well as in more than 45 years of research in the western part of Ukraine [4-8]. Global warming leads to a decrease in the productivity of agrocenoses. The Earth is warming faster than the territories above the oceans. Over the period 2011-2020, temperatures above them were 1.59° higher than in the period 1850-1900 [2]. This leads to changes in the frequency and type of precipitation: a shift in the beginning and end of the growing season, a decrease in water availability, or a change in the species composition and number of insects inhabiting certain areas (both beneficial, such as pollinators, and those that cause damage to crops).

The faster these changes occur, the more difficult it is to adapt to them. The measures and techniques used may not be sufficient to maintain farm production levels in the short term. This makes it difficult to plan crops or conduct breeding in a profitable way. In addition, it is much more difficult for agriculture to adapt to extreme weather conditions than to changes in average temperature or precipitation. Tropical nights, heat, or drought can completely destroy crops, while heavy rainfall or flooding can make agricultural work difficult or impossible, cause losses due to anaerobic conditions in the soil (root death, root diseases), and significantly increase erosion, which destroys the fertile soil layer.

The rise in the Earth's temperature is already affecting crop yields around the world, causing, for example, a global decline of almost 13% in oil palm and an increase of almost 3.5% in soybeans. The negative impact of global warming is noticeable primarily in Europe (in the western and southern parts of the continent, yields of major crops decreased by 6-21%), southern Africa and Australia, while the

Combining science, education, and production as a way to form an effective mechanism for preventing climate change

positive impact is in Latin America. For example, in China, climate change-related losses in corn and soybean crops (total) amounted to approximately USD 820 million in the first decade of the 21st century, and in the United States, losses in the livestock sector due to heat are estimated at USD 1.7-2.4 billion per year. In the case of Europe, more frequent and severe droughts are and will continue to be a big problem. With a global temperature increase of 3oC, which according to current policy will occur by 2100, the area affected by droughts will increase by 40% and more extreme droughts will occur. Therefore, limiting the rate of increase in the Earth's temperature is crucial from the agricultural perspective, and maintaining the warming threshold well below 2°C will reduce the severity of the negative effects of climate change [2; 3;10-15].

Long-term studies by a number of authors have shown that changes in land use affect the albedo of certain areas. Thus, replacing a dark forest zone with a light cultural zone can theoretically have a “cooling” effect on the climate. The problem is that it can be easily offset by both greenhouse gas emissions and changes in evaporation. Evapotranspiration over forests is higher than over areas covered with low vegetation, which makes forested areas cooler. This is important for the local microclimate. Scientific studies have also shown that dry, heated air masses that form over fields and areas covered by low vegetation in summer can cause or exacerbate droughts in other regions.

On the other hand, in winter, if it snows, the albedo of fields will be lower than that of forests. The solution may be to use light plant species/varieties in areas with dark soils and generally preserve vegetation cover on fields. An important reserve in this regard is the sowing of intercrops (post-harvest, post-harvest, in the form of undercrops and winter crops), i.e. agro-rocenoses that grow between the harvest of the main crop of the crop rotation and the sowing of the next main crop [2; 4; 7; 9; 16].

An indifferent and negligent attitude to the condition of the soil cover creates favorable conditions for the development and deepening of soil erosion processes, as

Combining science, education, and production as a way to form an effective mechanism for preventing climate change

the open soil surface is much more prone to blowing away and washing away the most fertile topsoil. Erosion processes (wind and water) are important from a climate perspective, as they deplete the soil's organic carbon reserves. They also contribute to a decrease in yields, as the soil structure is destroyed and at the same time nutrients valuable for plants are lost. More and more scientific studies show that soil health is crucial for the production of food, feed, and raw materials for the processing industry. The presence of symbiotic mycorrhizal fungi improves the conditions for the development of the plant root system.

Nutrients include nitrogen and phosphorus, which are supplied to agricultural fields mainly in the form of fertilizers. If they are not absorbed by plants, they are easily washed away by water from an open field. Over time, they reach the seas and oceans, where they contribute to the formation of the so-called dead zone. In addition to having a negative impact on fisheries, these zones are also a large source of nitrous oxide. The more ingredients like nitrogen in the soil that are not utilized by plants, the more serious the problem.

Climate change can also exacerbate negative phenomena such as decreased organic matter, salinization, loss of soil biodiversity, landslides, desertification, and flooding. The impact of climate change on soil carbon dioxide storage may be related to changes in atmospheric CO₂ concentrations, rising temperatures, and changes in precipitation patterns, such as extreme precipitation, rapid snow or ice melting, full river flows, and more frequent droughts, which contribute to soil degradation. Deforestation and other human activities (agriculture, skiing, etc.) also play an important role.

The previously mentioned intermediate crops (green manure, fodder, seeds, etc.) help to mitigate this phenomenon. They absorb some of the nutrients left in the soil after the main crop is harvested. In addition, the roots of plants “bind” soil particles, limiting their movement, and the leaves create a much more favorable microclimate, reducing, for example, the degree of soil exposure in summer, and thus its drying out, which contributes to soil blowing away (wind erosion).

Combining science, education, and production as a way to form an effective mechanism for preventing climate change

Intermediate crops serve as “green fertilizers”, i.e., plants that enrich the soil with nutrients. A classic example is legumes, which contain symbiotic nitrogen-fixing bacteria in the root layer. Such crops can also be used as fodder for farm animals, which makes it possible to limit the size of the area devoted exclusively to fodder crops. Therefore, it is clear that appropriate methods and scientifically sound application of fertilizers (mineral and organic) can be important not only for the amount of harvest, farm budget, greenhouse gas emissions in the field (mainly nitrous oxide), but also for processes that take place in fields far from farmyards. The provision of soils with organic substances in combination with green manure and plant residues (straw, leaves, stems, etc.) has become even more important due to the acute shortage of organic fertilizers of animal origin, and the use of only insufficient amounts and inappropriate proportions of mineral fertilizers does not provide the expected effect [4-7].

The search for energy sources was and is quite problematic during the energy crisis. In recent years, the energy crisis has prompted experts to search for various forms and methods of using biomass for fuel, although in reality this type of activity is often carried out in connection with agriculture. It includes the traditional burning of stubble, wood, dead grass, etc., which is an important reserve for their reasonable use to replenish organic matter in the soil. It is also used in home biomass stoves, mini-boilers, etc. It is known that biomass combustion causes about 11% of total anthropogenic N₂O emissions and is one of the world's main sources of carbonate aerosols that adversely affect human health. In addition, the “black carbon” (soot) contained in them absorbs solar radiation, exacerbating global warming (both when floating in the air and as a result of settling on the Earth's surface, covering its surface components).

An important segment of agricultural production and an integral part of successful farming is the livestock industry. Unfortunately, in Ukraine, the link between this chain is rather weak due to objective and subjective reasons, and there are practically no organic fertilizers of animal origin! This problem is also shared by

Combining science, education, and production as a way to form an effective mechanism for preventing climate change

other EU countries, as the development of livestock breeding also creates environmental problems. Since 2000, approximately 1/3 of the world's total anthropogenic methane emissions have been caused by intestinal fermentation of ruminants. Although various attempts are being made to influence the amount of methane produced by animals, such as dietary changes (better quality, more digestible feed), feed additives (reducing methane production by positively influencing the microorganisms of the ruminant digestive system), and responsible breeding (better animal husbandry methods, breeding new or older breeds that are more resistant to environmental conditions), the greatest potential for reducing these emissions is on the demand side. Reducing demand for meat and dairy products will lead to a reduction in the population of ruminants (there are currently about 1.5 billion cows in the world). Since animals require a huge amount of feed (for example, 3/4 of the world's soybean crops are used for this purpose), this will also free up soil for other needs.

In agriculture, the way soil is used can also affect the methane balance, for example, by reducing the amount of methane in the atmosphere through measures that increase soil uptake. As with N_2O , the key here is to reduce fertilizer inputs and improve soil structure. In the case of methane, maintaining natural forests and grassland ecosystems has great potential to reduce methane emissions [17-21].

The goal of managing grants is to ensure their long-term productivity and ecological functionality so that agricultural production can continuously meet the needs of society (this is called “sustainable” management). Modern agriculture on a global scale needs to be reoriented toward a transformation that includes adaptation and mitigation of the negative impacts of climate change at the same time. A number of methods to reduce greenhouse gas emissions on farms provide direct or indirect financial benefits and at the same time allow for adaptation to climate change. In this way, the transformation of agriculture, which is necessary due to the current state of the earth's systems, can reconcile both economic (farmer's income), social (food supply), and environmental (reducing pressure on the natural environment) needs.

Combining science, education, and production as a way to form an effective mechanism for preventing climate change

Mitigation activities in agriculture are important because projections of changes in global soil organic carbon resources in the 21st century vary widely. The key uncertainty is the difference between the warming-related increase in CO₂ emissions (plant and microbial respiration) and the increase in the rate of carbon uptake by plants.

Experts consider agroecology, various soil protection systems, precision farm management technologies, the use of methods based on natural solutions (biological plant protection), and the increase and protection of agricultural diversity (crop rotation, intercrops, local varieties/hybrids, compacted and compatible crops) to be important effective methods for the future of agricultural production. The last mentioned method is very important in terms of adaptation and food security. Over the course of the 20th century, 75% of food crops were lost due to replacement by genetically homogeneous, high-yielding varieties, and about 80% of the world's fields are planted with multiple crops (corn, wheat, rice, soybeans, etc.). This is important because, in the case of specialized farms, the occurrence of an extreme event (late frost, hail, heat, or drought) can completely destroy crops. Rich genetic diversity is a kind of insurance policy that makes it possible to choose species, breeds and varieties that are better adapted to climate change in the future [4-7].

For developing farmers who farm on small areas, returning to or preserving traditional methods based on closer contact with nature, reconnecting crop production with animal husbandry, can support adaptation and improve the functioning of local ecosystems. Such agricultural systems tend to be much more resilient to extreme weather events, disease epidemics, or the emergence of crop-feeding organisms (pests). They also require minimal use of external inputs, which reduces the farm's dependence on price fluctuations/availability of products on world markets, such as chemical fertilizers or crop protection products, while reducing the human impact (mechanization of agriculture) and the use of fossil fuels. In addition, intensification of agriculture in close combination with livestock production contributes to increased farm productivity, reduced emissions intensity, and serves as an additional option for

Combining science, education, and production as a way to form an effective mechanism for preventing climate change

climate change adaptation. In general, diversification of production makes it possible to preserve at least part of the farm's income in the event of extreme events. However, it is important that solutions are adapted to the local context and conditions, both climatic and social.

REFERENCES

1. Zhao W., Zhao Y., Qin F. Holocene fire, vegetation, and climate dynamics inferred from charcoal and pollen record in the eastern Tibetan Plateau. *J. Asian Earth Sci.* 2017. Vol. 147. P. 9-16, DOI: 10.1016/j.jseas.2017.07.017 [in English].
2. IPCC: Climate Change 2022: Impacts, Adaptation, and Vulnerability, Contribution of Working Group II to the Sixth Assessment Report of the Intergovernmental Panel on Climate Change, edited by: Pörtner, H.-O., Roberts, D. C., Tignor, M., Poloczanska, E. S., Mintenbeck, K., Alegría, A., Craig, M., Langsdorf, S., Lösschke, S., Möller, V., Okem, A., and Rama, B., Cambridge University Press, Cambridge University Press, Cambridge, UK and New York, NY, USA, 2022. 3056 p. DOI: <https://doi.org/10.1017/9781009325844> [in English].
3. Ray Deepak K., West Paul C., Clark M., Gerber James S., Prishchepov A. V., Chatterjee Snigdhanu. Climate change has likely already affected global food production. *PLoS ONE*, 2019, Vol 14, Issue 5, p.1. DO;I 10.1371/journal.pone.0217148 [in English].
4. Begei S.V., Shuvar I.A. Intermediate crops in intensive agriculture: a textbook. Lviv, 1992. 104 p. [in Ukrainian].
5. Begei S.V., Shuvar I.A. Ecological farming: a textbook. Lviv: Novyi Svit-2000, 2007. 429 p. [in Ukrainian].
6. Borysiak O., Brych V., Haida Yu. et al. *Development of agrarian nature management in the context of climate change*: monograph. Edited by Doctor of Economics, Professor Brych V. Y. Ternopil: ZUNU, VNC “University Thought”, 2023. 153 p. [in Ukrainian].
7. Adaptive farming systems: a textbook / V. P. Gudz, I. A. Shuvar, A. V. Yynyk, I. P. Rikhlovsky, Y. G. Mishchenko. K.: Center for Educational Literature. 2nd ed. revised and supplemented, 2014. 336 p. [in Ukrainian].
5. Straw, post-harvest residues and green manure - agrotechnological elements of biologization of modern agriculture: monograph / Ivanyshyn V.V, Shuvar I.A, Bakhmat M.I, Sendetskyi V.M, et al. Ivano-Frankivsk: Symphony forte, 2020. 292 p. [in Ukrainian].
6. Shuvar I.A. Siderates in modern agriculture: scientific and production publication (monograph) / I.A. Shuvar, O.M. Berdnikov, V.M. Sendetskyi, O.V. Tymofiychuk, V.S. Hnydiuk, O.M. Bunchak, L.V. Tsentilo, N.M. Kolisnyk, B.V.

Combining science, education, and production as a way to form an effective mechanism for preventing climate change

Tymofiychuk; Edited by I.A. Shuvar. Ivano-Frankivsk: Symphony forte, 2015. 156 p. [in Ukrainian].

7. Shuvar I.A., Roik M.V., Ivanyshyn V.V. et al. Sideration in the technologies of modern agriculture: scientific and production publication (monograph) / [Shuvar I.A., Roik M.V., Ivanyshyn V.V., Sendetskyi V.M., Tsentilo L.V. et al. Ivano-Frankivsk: Symphony forte, 2016. 182 p. [in Ukrainian].

8. Shuvar I.A., Snitynskyi V.V., Balkovskyi V.V. Ecological bases of balanced nature management: a textbook. Lviv-Chernivtsi: Books - XXI, 2011. 760 p. [in Ukrainian].

9. Chen, D.-T.V., Wang, Y.-M., Lee, W.C.: Challenges confronting beginning researchers in conducting literature reviews. *Stud. Contin. Educ.* 2015. 38(1), P. 47-60. DOI: <https://doi.org/10.1080/0158037X.2015.1030335> [in English].

10. Samoy-Pascual K., Evangeline B. Sibayan, Filomena S. Grospe, Alaissa T. Remocal, Agnes T-Padre, Takeshi Tokida, Kazunori Minamikawa. Is alternate wetting and drying irrigation technique enough to reduce methane emission from a tropical rice paddy? *Soil Science and Plant Nutrition*. 2019. Vol. 65(2). P. 203-207, DOI: [10.1080/00380768.2019.1579615](https://doi.org/10.1080/00380768.2019.1579615) [in English].

11. Cheng, L., Trenberth, K. E., Fasullo, J., Boyer, T., Abraham, J., and Zhu, J.: Improved estimates of ocean heat content from 1960 to 2015. *Sci. Adv.* 2017. Vol. 3, e1601545, <https://doi.org/10.1126/sciadv.1601545> [in English].

12. Gleckler, P. J., Durack, P. J., Stouffer, R. J., Johnson, G. C., and Forest, C. E.: Industrial-era global ocean heat uptake doubles in recent decades, *Nat. Clim. Chang.* 2016. Vol. 6. P. 394–398. DOI: <https://doi.org/10.1038/nclimate2915> [in English].

13. Thornton and Herrero P.K. Thornton M. Herrero Adapting to climate change in the mixed crop and livestock farming systems in sub-Saharan Africa. *Nat. Clim. Chang.* 2015. Vol. 5. P. 830-836. DOI: [10.1038/nclimate2754](https://doi.org/10.1038/nclimate2754) [in English].

14. Anthropogenic warming exacerbates European soil moisture droughts. *Nat. Clim. Change*. 2018. Vol. 8(5). P. 421-426. DOI: [10.1038/s41558-018-0138-5](https://doi.org/10.1038/s41558-018-0138-5) [in English].

15. Howe Peter D., et al. Geographic and demographic variation in worry about extreme heat and COVID-19 risk in summer 2020. *Applied Geography*. 2023. Vol. 152, 102876 [in English].

16. Kaye J.P., Quemada M. Using cover crops to mitigate and adapt to climate change: A review. *Agron. Sustainable Dev.* 2017. Vol. 37, 4 [in English].

17. Altieri, Miguel A., and Clara I. Nicholls. The adaptation and mitigation potential of traditional agriculture in a changing climate. *Climatic change*. 2017. Vol. 140. P. 33-45 [in English].

18. Lu J., Li X. Review of rice-fish-farming systems in China - one of the globally important ingenious agricultural heritage systems (GIAHS). *Aquaculture*. 2006. Vol. 260. P. 106–113. DOI: [10.1016/j.aquaculture.2006.05.059](https://doi.org/10.1016/j.aquaculture.2006.05.059) [in English].

19. Mbow C., Smith P., Skole D., et al. Achieving Mitigation and Adaptation to Climate Change through Sustainable Agroforestry Practices in Africa. *Current*

Opinion in Environmental Sustainability. 2014. Vol. 6. P. 8-14. DOI: <http://dx.doi.org/10.1016/j.cosust.2013.09.002> [in English].

20. Samaniego, L., Thober, S., Kumar, R., Wanders, N., Rakovec, O., Pan, M., Zink, M., Sheffield, J., Wood, E.F., Marx, A. Anthropogenic warming exacerbates European soil moisture droughts. *Nat. Clim. Change*. 2018. Vol. 8. P. 421–426. DOI: <https://doi.org/10.1038/s41558-018-0138-5> [in English].

21. Brett F., Sanders Jochen E. Schubert Kristen A. Goodrich, Douglas Houston, David L. Feldman, Victoria Basolo. Collaborative modeling with fine-resolution data enhances flood awareness, minimizes differences in flood perception, and produces actionable flood maps. *Earth's Future*. 2020. Vol. 8(1). DOI: [10.1029/2019EF001391](https://doi.org/10.1029/2019EF001391) [in English].

SECTION 2.5 CLIMATE CHANGE, INTENSIVE USE OF PESTICIDES AND THEIR NEGATIVE IMPACT ON CITRUS CULTURE

Narguli Asanidze

Giorgi Turmanidze

Batumi Shota Rustaveli State University, Georgia

Climate change is one of the most important challenges facing the modern world, which threatens humanity and our planet. Georgia is already feeling its impact. Today, agriculture is also affected by the negative impact of climate change.

Climate change is causing a large increase in pests of agricultural crops in agriculture, which has a negative impact on the yield and other characteristics of agricultural crops. When the number of pests is much higher than the limit norms, then it becomes necessary to use pesticides sometimes over-intensively. Our goal was to conduct a study on the negative impact of this way of fighting against gnawing beetle (*Ostoma terruginea*) on citrus crops in my region - citrus poisoning with pesticides.

As you know, pesticides are Bifenthrin- insecticideint against gnawing beetle (*Ostoma terruginea*). Bifenthrin is a broad-spectrum insecticide that acts on a nerve cell's ability to send a normal signal by blocking the tiny gates open on the cell, which must open and close rapidly to send the message. Bifenthrin is used in agriculture and residential environments, both indoors and outdoors.

What insects does bifenthrin kill? On a large scale, bifenthrin is often used against invasive red fire ants. It is also effective against aphids, worms, other ants, grubs, night beetles, earwigs, grasshoppers, mites, midges, spiders, mites, yellow jackets, nettles, thrips, caterpillars, flies, fleas, sawflies and termites. Bifenthrin is not a contact kill product, it is a residual product that may take several days to begin

*Combining science, education, and production as a way to form an effective
mechanism for preventing climate change*

killing fleas or other insects we are treating for. We need to give the product time to do what it was designed to do. If the infestation with fleas is large, after 7-14 days we can treat again.

A large volume of Bifetherine is used to kill Aphidinae and various worms as well as invasive red fire ants. Bifenthrin is not a contact dead product, it is a residual product that may take several days to begin killing fleas or other insects we are treating it for. We need to give the product time to do what it was designed to do. If the infestation with fleas is large, after 7-14 days we can apply for it again.

Our task was to find out how the use of Bifenthrin had a negative effect on the Washington-Navel citrus crop in our region; therefore, we decided to investigate what exactly harmed this crop. We will dynamically continue the research in the future as well. Orange Washington-Navel is a medium-sized tree-plant, mainly blooms once a year. A longer period of 220-250 days is required for fruit ripening. The sum of the active temperatures should be up to 4500. It requires more heat and tolerates higher temperatures than lemon. Vegetation begins at a temperature of 11-12 degrees, and goes into a state of rest at about the same temperature. Fruit ripening continues until late winter in our region. The absolute minimum is -10°C , at -6°C it is weakly damaged, and at -8 it is moderately damaged. Citrus fruits are native to typical monsoon regions, where there is a large amount of atmospheric precipitation in summer, and a relatively dry autumn-winter period when the fruit ripens. If at this time citrus fruits suffer from a moisture deficit, they develop the property of giving moisture from the ripe fruit, as a result the fruit loses its juiciness and becomes rough. The same lack of moisture causes a large number of young fruit to fall in the spring. All of the above should be taken into account during the production of citrus fruits, and irrigation should be carried out in the corresponding period. Citrus trees also adapt well to high air humidity. A content of 1-1.5 degrees of free water in the soil is quite enough to meet the demand for water, and if it falls below 1%, then there is a water deficit. Citrus trees belong to the group of mesophytic plants.

The research was conducted by us in the Ajara region, in the citrus plantation located close to the village Makhinjauri. In 2017-2018, the Ministry of Agriculture of Ajara conducted a campaign against *Ostoma Terrigaea* in citrus plantations using the chemical pesticide Bifethrin in the spring, during the flowering period of citrus trees. Application of the pesticide in the citrus took place only in the area adjacent to the road. In the depth of the plantation, on the lower slope pesticide could not be applied. Two months after the treatment, one root of Washington-Navel orange withered. Most of the flowers on the rest of the stem have fallen off. In the part that remained, we noticed a sharp change in both morphological and taste characteristics of the fruits harvested in the fall. In the area where the pesticide was not applied, Washington-Navel oranges did not change either in terms of morphological or taste characteristics. In the following years, the changes of the mentioned properties can be observed in the harvest, but insignificantly every year. It should be noted that these changes were most visible in the orange Washington-Navel; thus, why we decided to investigate it.

The results of the study are given in the table 2.5.1.

Table 2.5.1 - Comparative characteristics of oranges

The area where pesticide was applied	The area where pesticide was un applied
Skin - damaged, with brown spots	Skin - healthy
Color - yellow	Color - orange
Taste - sour-sweet	Taste - sweet, slightly sour
Shape - round	Shape - round
Weight - 80.3-142.2 g	Weight - 218,2-220,5 g
Dry stuff by refractometer - 11.4%	Dry stuff by refractometer - 14,4%
Vitamin C – 49.9 mg%	Vitamin C – 58,76 mg%
Total carotenoids - 2.44 mg%	Total carotenoids - 5,05 mg%

Standard methods of analysis were used for the research: determination of dry stuff - thermogravimetric method (AOAC official Method); - quantitative determination of water-soluble dry substances by means of a digital refractometer (Carl Zeiss, Germany) (AOAC official method); - determination of total titration acidity and pH value on an automatic titrometer (Mettler-Toledo AG, analytical

Combining science, education, and production as a way to form an effective mechanism for preventing climate change

www.mt.com/education-line CH-8603 Schwerzenbach, Switzerland); - Quantification of vitamin C using titration iodometric method (AOAC official method) - Determination of carotenoids by spectrophotometric method (AOAC official method). The table clearly shows the degradation of both external morphological and taste properties of Washington-Navel oranges treated and untreated with the pesticide (soil-climatic regime, the degree of soil fertility is the same).

Since mandarin and lemon trees were not treated in the same plantation, we could not make a comparative analysis with mandarin and lemon. The mentioned data confirm that the fruits of the trees for which the pesticide was applied with all indicators shows the damage: "damaged skin, brown spots, yellow color, taste sour-sweet, healthy sweet-slightly sour" and other characteristics as well as dry content, vitamin C content, total carotenoids are significantly inferior in comparison to the fruit for which the pesticide as not applied.

According to Academician Giorgi Kvesitadze, until recently, the plant was not considered at all as an organism capable of breaking down compounds uncharacteristic of nature, including compounds with a complex structure, and foreign compounds through metabolism. This process is carried out by the plant by the synthesis of characteristic metabolites of the cell at the expense of the decomposition of the organic part of compounds foreign to it. As a result of ten years of research, it has been unequivocally proven that the plant has the ability not only to absorb these foreign substances through its roots and leaves, but also to carry out metabolic conversion to harmless cellular components. If we judge by the dynamics of the years according to our research citrus orange Washington-Navel, compared to the previous years, the taste qualities improve slightly, but improve. Obviously, we do not end our research here and we will also study the dynamics of the next years. The mentioned research allows us to make the following conclusion:

1. We think that the pesticide for the above-mentioned citrus tree was applied by wrong dosage, specifically by excessive dosage;

Combining science, education, and production as a way to form an effective mechanism for preventing climate change

2. The pesticide was applied in the spring during the flowering period of the plant, which, I think, is an incorrectly planned event. Moreover, it is possible that the plant underwent a mutation.

It should be taken into account that the research was also carried out on the annual dynamics of heavy metal content on the growing citrus trees of the same plantation in polluted and clean environment. According to this study, Washington-Navel oranges are particularly sensitive to heavy metals among citrus trees. I think that the mentioned variety should be more sensitive to compounds with a complex structure compared to other citrus fruits (mandarin, lemon), including pesticides. Washington-Navel oranges were found to be more sensitive to pesticides than mandarins and lemons.

Based on the mentioned conclusion, the following recommendations can be made.

1. Pesticides shall not be applied in the citrus plantations during their flowering period;
2. Check and determine the exact doses and concentrations of the pesticides with which citrus is planned to be treated.

REFERENCES

1. Agricultural Ecology, Vakhtang Gogvadze, Rezo Jabnidze, 2003, Batumi;
2. Asanidze N., "Annual dynamics of heavy metal content in plants", "Universal" publishing house, Tbilisi, 2018;
3. Kvesitadze G., "Modern ecology, state of the environment, causes of imbalance and remedial technologies";
4. Climate Change Law of Georgia (White Paper), Public Consultation of the Environment Protection and Natural Resources Committee of the Parliament of Georgia, November, 2023.

CHAPTER 3

CLIMATE CHANGE AND THE TRANSPORTATION SYSTEM

*Combining science, education, and production as a way to form an effective
mechanism for preventing climate change*

SECTION 3.1 CLIMATE CHANGE AND THE TRANSPORT SECTOR

Kozlovskiy Oleksandr

State Enterprise “Administration of River Ports”, Ukraine

3.1.1 General description of climate change impacts on the transport sector

Today, the dynamics of climate change is observed all over the world, and the peculiarity of this process is that it is recorded both at the global and local levels. The driver of accelerating global climate change is the use of fossil fuels as an energy resource. This leads to an anthropogenic increase in the content of greenhouse gases in the atmosphere. The implementation of the concept of sustainable development with a gradual reduction of greenhouse gas emissions is based on both the adoption of a differentiated approach to the use of energy resources and on making adjustments to the activities of various industries, including transport.

As climate risks for the transport industry, it is noted that climate change and its consequences can negatively affect both the construction and operation of transport infrastructure facilities.

The following climate factors and risk levels have been identified as a result of the assessment of climate risks for the global transport sector:

- thawing of permafrost: very dangerous level (70% of transport infrastructure facilities in the Arctic zone);

- Increase in average temperatures, periods of abnormal heat/drought: dangerous level (100% of transport infrastructure facilities);

- changes in the average sea level, increased destructive power of storms: dangerous level (100% of transport infrastructure facilities located in coastal areas);

- Changes in the intensity and frequency of extreme precipitation (floods and droughts): very dangerous level (100% of transport infrastructure facilities);

*Combining science, education, and production as a way to form an effective
mechanism for preventing climate change*

- natural fires: dangerous level (100% of transport infrastructure facilities in regions with a high risk of natural fires);
- strong winds/threats: dangerous level (100% of transport infrastructure facilities) [1].

3.1.2 Assessment of climate risks for transport facilities

When assessing the level of risk of climate factors, it is advisable to evaluate not only the percentage of transport infrastructure facilities that will be affected, but also the damage to the transport infrastructure facility, as well as the probability of this climate risk. To estimate the probability, the criteria given in the IPCC assessment report can be used: 99-100 % probability is practically certain, 90-100 % very likely, 66-100 % likely, 33-66 % most likely, 0-33 % unlikely, 0-10 % very unlikely, and 0-1 % extremely unlikely [2].

In addition, climate change, along with an increase in the likelihood of natural disasters, may be accompanied by hazardous natural processes that are not typical for the area. This leads to low or no preparedness to respond to this extreme event in the area. In this regard, when assessing probability, it is advisable to use the Bayesian method, which takes into account the a priori probability when determining the a posteriori probability of climate risk realization. This approach will allow to take into account regional specifics when identifying the frequency of adverse events, which is used in assessing climate risks for each specific transport infrastructure facility, taking into account the scenario structure of climate change [5].

Gravitational exogenous geological processes, such as landslides, collapses, and landslides, are not currently identified as climate risk factors. At the same time, an increase in the amount and intensity of precipitation in the warm season leads to a significant increase in the likelihood of adverse consequences associated with the loss of slope stability. Such risks increase significantly when dry periods alternate with periods of intense rainfall.

Combining science, education, and production as a way to form an effective mechanism for preventing climate change

3.1.3 Adaptation of communication and automation systems to climate change

The list of priority adaptation measures does not include adaptation of communication and automation systems, in particular electronic equipment that experiences significant overloads when operating in elevated temperatures (e.g., cities are exacerbating human-induced warming at the local level). However, climate change increases the likelihood of hazardous natural processes that can trigger man-made emergencies.

Most railway facilities show an increased failure rate even at moderately low temperatures, such as 20 °C, with the frequency of accidents increasing significantly above 26 °C [2]. These temperatures are within climatological temperature limits, as well as within the required performance characteristics of rail infrastructure.

Thermal expansion can also affect overhead power lines. As overhead lines expand, their tension decreases, which can lead to excessive sagging. The incidence of overhead line sagging is also higher in urban areas due to the urban heat island effect, which can result in urban areas being several degrees warmer than their surroundings, and further urbanization, along with more frequent extreme heat waves, will increase the strength of heat waves. Cities are often important transportation hubs, and a failure here can be very problematic, quickly spreading to the rest of the network, causing significant delays in the transportation of passengers and goods. Therefore, understanding the nature of heat-related incidents at such critical locations is essential.

The effect of heat on signaling equipment (signaling, centralization, interlocking) is much less well studied. Signaling and interlocking is a set of electromechanical devices designed to ensure the safety of train traffic, increase the capacity of tracks and stations, and eliminate manual operations. Unlike overhead lines, modern types of signaling equipment tend to be more susceptible to heat-related failures due to their increased dependence on electrical and electronic components. Equipment exposed to direct sunlight is most vulnerable to overheating,

Combining science, education, and production as a way to form an effective mechanism for preventing climate change

and in particular, equipment inside containers can experience faster temperature changes and higher temperature extremes than those outside [1].

There are the following causes of failures related to the effects of climate change on transport infrastructure.

- most heat-related events occur in the early to mid-summer period and then decline, despite temperatures remaining high. This is due to the correction of any equipment failures that occur during the hottest period and suggests that the transportation infrastructure system becomes increasingly resilient during the summer as faulty equipment is repaired or replaced. Shading from artificial structures or trees, the degree of which can vary depending on the time of day and season, is the main cause of spatial variations in overheating failures.

- There is a significant vulnerability of signaling equipment to heat. In addition, there is an increased likelihood of track distortion, heat-related accident response costs, and an increase in the number and duration of delays in passenger and freight transportation.

- A wide range of equipment fails due to heat, at ambient temperatures that are within the operating range and within the climatic norms of the region. The reasons for failures may include the use of outdated equipment, and maintenance procedures cannot always be performed at high ambient temperatures [2].

The current approach to ensuring equipment resilience needs to be reviewed in the medium and long term. Because without targeted adaptation or mitigation of climate change, the incidence of equipment failures and track distortions will increase in a future warmer climate.

1) Managing thermal risks at critical nodes is imperative, especially in urban areas where the heat island effect can lead to significantly higher temperatures than in the surrounding area [3].

It is predicted that in the future, the rail network will face unprecedented challenges due to more frequent high temperatures, and without targeted adaptation or mitigation of climate change, the costs and delays associated with thermal risks

Combining science, education, and production as a way to form an effective mechanism for preventing climate change

will increase. Thus, increasing the climate resilience of the transportation network is now essential.

2) Training of personnel for the implementation of the climate change adaptation plan in the transport sector [1].

However, the climate crisis poses challenges to society that require a comprehensive approach and include not only organizational and technical tasks, but also changes in educational approaches.

Today, the use of geographical knowledge to independently assess the level of environmental safety and adaptation to changing conditions is: assess the level of environmental safety and adaptation to changing conditions; assess the impact of environmental changes on various areas of human activity at the regional level; compare, evaluate and argue different points of view on current environmental and socio-economic issues.

Climate change education should be approached at the institutional level, i.e., collective focus on the current and projected climate situation, with collective action [11].

3.1.4 Analysis of greenhouse gas sequestration technologies as climate change adaptation measures in the transport sector

Linking adaptation programs to greenhouse gas emission reduction measures will allow for greater flexibility in responding to changes in the forecasts presented in the scenario framework [3] and will also allow for the management of climate risk factors. One of the ways to adapt or mitigate the effects of climate change in terms of adaptation in the field of transport is the development and implementation of greenhouse gas emission absorption technologies [1]. The types of greenhouse gas sequestration technologies that can be implemented in the transport sector can be categorized as follows:

Combining science, education, and production as a way to form an effective mechanism for preventing climate change

1 Afforestation and reforestation absorbs carbon dioxide in the process of forest growth. The advantage of this technology is that it is a known technology and can be implemented at low cost. However, it should be borne in mind that large areas of forests are required to absorb a significant amount of carbon dioxide. At the same time, there is a threat of release of carbon stored in wood in case of violation of planting technologies. Nitrous oxide emissions are possible when fertilizers are applied to stimulate forest growth. It is also necessary to protect forests from natural fires. In arid areas, the need for water can also be a significant limiting factor.

2. Bioenergy production with carbon capture and storage (BECCS). This technology is based on the fact that biomass, which accumulates carbon during growth, stores it in the form of organic material. This biomass can be burned at power plants (or converted into other forms of energy) to produce electricity. At the same time, the carbon dioxide generated during combustion is captured and buried. Biomass can be used to produce hydrogen, biofuels or biogas. This technology has been implemented in demonstration models, but its effectiveness must be assessed on a case-by-case basis.

3. Direct ambient air CO₂ capture and storage (DACCS). A significant portion of anthropogenic greenhouse gas emissions comes from distributed sources. Capturing these emissions at the source is often inefficient and impractical. To remove these emissions, carbon dioxide can be captured directly from the ambient air. Implementation of direct capture technology from the atmosphere requires a source of energy and/or heat with a minimal carbon footprint, which limits the choice of a suitable location to areas where there is access to such a source. Direct capture uses a sorbent to absorb carbon dioxide in a solid or liquid phase. After carbon dioxide is absorbed, the sorbent is regenerated to produce highly concentrated carbon dioxide, which is then transported and disposed of. For example, in underground cavities from which hydrocarbons are extracted and then injected into rocks [4].

Since carbon capture and storage (CCS) acts as a component in categories 2 and 3 above, and is also a technology for direct mitigation of impacts from point

Combining science, education, and production as a way to form an effective mechanism for preventing climate change

sources of carbon dioxide emissions, this technology can be considered as a separate technology of negative emissions [5].

3.1.5 Inclusiveness in the development of climate change adaptation measures for transport

The goal of climate change adaptation is to set quantitative parameters, including timeframes, for specific measures for specific transport infrastructure facilities, taking into account priority climate risks, by focusing on specific measures for specific transport infrastructure facilities.

Interaction with stakeholders (infrastructure owners, related organizations, executive authorities and local governments) is crucial here, as infrastructure facilities are part of an interdependent system, and a weather-related failure of an adjacent infrastructure network (e.g., power supply) may affect transport infrastructure. External stakeholders can also provide information on the vulnerability of the facilities they manage to climate risks.

Priority adaptation measures in the field of transport include

- Amendments to regulatory and methodological documents aimed at taking into account the changing climate during the design, construction, and operation of transport infrastructure facilities;

- development of a monitoring system for engineering and geocryological conditions to monitor the condition of linear infrastructure facilities and development of a sectoral methodology for calculating climate risks and assessing the effects of climate change;

- creating a system for monitoring climate change and natural emergencies on highways, as well as developing a digital platform with an interactive map of highways with predicted risks of climate change impact;

- conducting research on the impact of climate risks on the provision of insurance services to transport companies;

Combining science, education, and production as a way to form an effective mechanism for preventing climate change

- compiling a list of transport infrastructure facilities vulnerable to the effects of climate change;
- creation of a test site for testing new binding materials for road construction and maintenance, including the development of regulations for their use;
- increasing the capacity of inland waterways, eliminating the negative impact of climate change and ensuring the depths required for navigation [5].

The assessment showed that in some cases, the negative impact factor in the climate risk assessment may not be the hazardous natural process itself, but a natural or man-made phenomenon initiated by it and, in turn, affecting a particular transport infrastructure facility. When analyzing climate risk factors, it is necessary to identify all possible objects of risk exposure (an object that is exposed to a hazardous event, adverse weather conditions, or abnormal climatic conditions). In this case, the increase in damage is determined not only by climate risk factors but also by the vulnerability of transport infrastructure facilities. Vulnerability is determined by both the significant degree of deterioration of facilities and existing deviations from building codes and regulations. In addition, the vulnerability is particularly pronounced in facilities located in areas of high climate risk.

Taking into account the proposals for improving the climate change adaptation plan in the field of transport will make it possible to provide the necessary funding for adaptation measures, assess climate risks for transport facilities, taking into account the a priori probability of adverse events, take into account the growing impact of exogenous geological processes on transport facilities, focus on the vulnerability to climate change of communication and automation systems in transport, and ensure the necessary level of professional training for the implementation of the adaptation plan, including

REFERENCES

1. Climate change: consequences and adaptation measures: analytical report / [S.P. Ivaniuta, O.O. Kolomiets, O.A. Malynovska, L.M. Yakushenko]; edited by S.P. Ivaniuta. - Kyiv: NISS, 2020. - 110 p.
2. Transport and climate change. Module 5e. Sustainable development of the transport system: a collection of materials for city policy makers - <http://supt.en>
3. On Approval of the Concept for the Implementation of the State Policy in the Field of Climate Change for the Period up to 2030. Order of the Cabinet of Ministers of Ukraine of 07.12.2016 No. 932-p. URL: <https://www.kmu.gov.ua/npas/249573705>
4. Low-Carbon Development Strategy of Ukraine for the period up to 2050 (2017). URL: <https://mepr.gov.ua/news/31815.html>
5. Information and analytical materials in the field of transport for the round table: "Is Ukraine ready for climate change: the role of parliament" // Annex to the letter of the Ministry of Infrastructure of 30.04.2020 No. 5796/39/10-20

SECTION 3.2 EUROPEAN TRANSITION TO DEVELOPMENT OF DECARBONISATION INNOVATIONS IN TRANSPORT AND LOGISTICS

Borysiak Olena,

Western Ukrainian National University, Ukraine

Climate change drives the search for innovative approaches to reducing greenhouse gas emissions by developing a low-carbon economy and enhancing the monitoring of environmentally friendly business processes in the context of sustainable mobility. European strategic goals for transitioning to a low-carbon economy include several environmental targets such as: the development of carbon markets; circular cities; energy efficiency in buildings; renewable energy; and enhancing climate resilience in agriculture and forestry.

In scientific literature, "sustainable transportation" is defined as "transportation that meets current transportation needs without compromising the ability to meet future needs. The criteria for sustainable transportation include: the degree of satisfaction of transportation demand, the technical and commercial viability of transportation technology (economic goals); production and regenerative functions (ecological goals); and cultural richness, institutional factors, social justice, etc. (social goals)" [1, p. 179]. According to this definition, the criteria for sustainable transportation are: "the degree of satisfaction of transportation demand, the technical and commercial viability of using appropriate transportation technologies, etc. (economic goals); the level of environmental production and regenerative functions (ecological goals); and the effectiveness of institutional factors, the level of social responsibility, etc. (social goals)" [1, p. 179]. This process aims to optimize the use of eco-friendly transportation vehicles by maximizing their deployment through identifying common priorities in the development of transportation logistics and

Combining science, education, and production as a way to form an effective mechanism for preventing climate change

enhancing the synergy between energy-efficient and low-carbon management of logistics chains for road freight transportation..

In this context, it is important to highlight the European Union's "Smart and Resilient Cities" concept, which integrates urban resilience and mobility, emphasizing that both aspects should be considered simultaneously. Its emergence can be seen as a response to criticism of smart city solutions that contradict sustainability and as an attempt to more fully address the needs of cities that are increasingly digitalized, compared to the traditional sustainability concept. [2-4]. A "smart and resilient city" is defined as an "innovative city that utilizes information and communication technologies and other means to improve the quality of life, operational efficiency, and services within cities, while also ensuring competitiveness and addressing the needs of current and future generations in economic, social, environmental, and cultural aspects" [5, p. 141-142].

The main priorities of the EU transport policy include the creation of a Single European Transport Area, based on the interaction of different modes of transport, and the emergence of multinational and multimodal operators. To establish an integrated transport system, combining several modes of transport, the White Paper envisions the introduction of a "single window" and "continuous administrative shop" by creating a single electronic transport document (electronic bill of lading), implementing "smart" transport systems, and developing "smart" infrastructure (both terrestrial and airborne) to ensure the interaction of various modes of transport [6].

"Historically, the automotive sector has been a leading industry in Europe and has made a significant contribution to economic growth and prosperity. However, to advance its green transition, the EU now mandates that, starting from 2035, all cars sold in the EU must be zero-emission vehicles. Such legislative requirements have accelerated global competition in the electric vehicle sector" [7].

In the European Union, the strategic document "ERTRAC Road Transport Scenario 2030+ 'Road to Implementation'" has been developed. It is documented to "represents a diverse group of stakeholders in a successful European transport

Combining science, education, and production as a way to form an effective mechanism for preventing climate change

system, including: car manufacturers, automotive market intermediaries and transport service providers, road infrastructure operators, energy and fuel suppliers, as well as experts in European public and local policy" [8, p. 153-154]. In this document, among the listed vectors for the greening of urban transport are the following:

- expenditures on electricity and greenhouse gas emissions from road transport should be stabilized through energy efficiency improvements, such as enhancing vehicle engines, and replacing non-renewable modes of transport with renewable ones;

- the energy efficiency of transport systems in cities should be improved through the application of both technological and non-technological measures, specifically by implementing energy-saving technologies in the automotive industry;

- the use of more electric-powered vehicles in public transportation chains of large cities, which should increase the focus on renewable energy sources;

- offering various incentive programs for businesses to fully engage in implementing new and economically efficient energy transport technologies, as demand and supply for energy-saving technologies must be balanced among all market participants: businesses, municipal and government authorities, transportation service consumers, and the public. [8, p. 153-154].

According to the European Green Deal, which aims to establish climate-neutral development for the European Union by 2050, priorities include the use of environmentally friendly and smart transport (electric vehicles), creating conditions for safe and resilient transport, and providing smart mobility services for passengers and goods ". "Considering this, an important area of innovative development in logistics for freight transport based on decarbonisation and energy efficiency is the formation of partnerships between energy service companies and transport service providers to expand access to renewable energy sources using artificial intelligence. The benefits of implementing innovations in safe, sustainable transport and smart mobility services for passengers and goods include enhanced safety on the road, environmental preservation, reduced accidents caused by human error, decreased

traffic congestion, reduced energy consumption and emissions from vehicles, and improved efficiency and productivity of freight operations.

In July 2024, the European Commission selected 134 transport projects to receive over 7 billion euros in grants from the Connecting Europe Facility (CEF), a strategic EU tool for investing in infrastructure. Nearly 83% of the funding will be allocated to support projects aimed at achieving EU climate goals, improving and modernizing railway networks, inland waterways, and maritime routes along the Trans-European Transport Network (TEN-T). The revised TEN-T Regulation came into effect on July 18, 2024 [9].

According to an analysis by McKinsey, "the economic advantage of electrification lies in the fact that the cost of electricity becomes lower than the cost of gas and CO₂" [10] (Fig. 3.2.1).

Share of hours with electricity prices below gas and CO₂, %

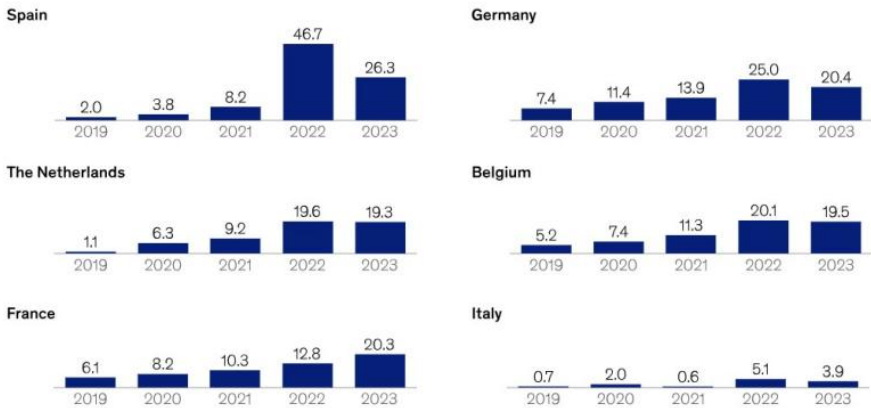

Figure 3.2.1 - Day-ahead electricity prices are falling below the costs of gas and CO₂ [10]

A decrease in prices usually coincides with an oversupply of renewable energy sources, meaning that "cheap hours" of electricity availability also represent "low-

Combining science, education, and production as a way to form an effective mechanism for preventing climate change

emission hours" (see sidebar "Advantages of Increasing Electricity Generation"). "Although significant price fluctuations were absent in 2022, a comparison of Germany and Spain shows that price volatility remains, particularly when examining the price difference between gas and electricity (Fig. 3.2.2). In both cases, the share of hours when electricity was cheaper than gas in 2023 ranged from 15% to 25%. Price fluctuations might increase in the future as additional renewable energy sources are integrated into the system". [10].

Distribution of price difference between gas and electricity, €/MWh

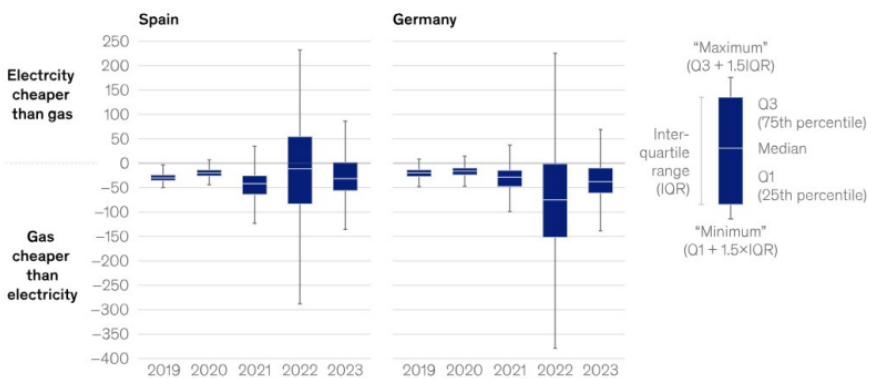

Figure 3.2.2 - While price volatility decreased after 2022, electricity was still cheaper than gas for 15 to 25 percent of hours in 2023 [10].

Therefore, "the implementation of environmental innovations is positioned as a goal for businesses to become more sustainable, reduce negative external effects, and meet the environmental requirements of governments and consumer demands" [11; 12]. With this in mind, the climate and environmental safety of energy and transport enterprises are ensured by transitioning to the production, marketing, and consumption of "green" energy, cyclic use of resources, and reducing greenhouse gas emissions at local and regional levels.

Combining science, education, and production as a way to form an effective mechanism for preventing climate change

REFERENCES

1. Zito P. Salvo, G. Toward an urban transport sustainability index : an European comparison. *European Transport Research Review*. 2011. Vol. 3. Issue 4. P. 179–195. URL: <https://link.springer.com/article/10.1007/s12544-011-0059-0> [in English].
2. Borysiak O., [Mucha-Kuś K.](#), Brych V., Kinelski G. Toward the Climate-Neutral Management of Innovation and Energy Security in Smart World : monograph. Berlin, Germany: Logos Verlag Berlin GmbH. 2022. 172 p. [in English].
3. Mykytyuk P., Brych V., Manzhula V., Borysiak O., Sachenko A., Banasik A., Kempa W.M., Mykytyuk Y., Czupryna-Nowak A., Lebid I. Efficient Management of Material Resources in Low-Carbon Construction. *Energies*. 2024. Vol. 17(3), 575. DOI: [in English].
4. Horal L., Prykhodko M., Havadzyn N., Melnychuk I., Berlous M. Ecosystem services in the management system of ecological safety of territorial units. *Modeling, Development and Strategic Management of Economic System (MDSMES 2019)*, in series : *Advances in Economics, Business and Management Research* : Proceedings of the 2019 7th Conference. 2019. Vol. 99. P. 90-95. DOI: <https://doi.org/10.2991/mdsmes-19.2019.18> [in English].
5. Huovila A., Bosch P., Airaksinen M. Comparative analysis of standardized indicators for Smart sustainable cities : What indicators and standards to use and when? *Elsevier*. 2019. № 89. P. 141-153. URL: <https://www.sciencedirect.com/science/article/pii/S0264275118309120?via%3Dihub> [in English].
6. Bolzhelarskyi Ya., Hrevtsov S. Combined transportation in the logistics system of the European Union and Ukraine. *Railway Supply*. 2022. URL: <https://www.railway.supply/uk/kombinovani-perevezennya-ta-%D1%97h-misce-u-transportnij-logistichnij-sistemi-%D1%94vrosoyuzu-ta-ukra%D1%97ni/> [in Ukrainian].
7. Zalc J. Attitudes of citizens in the EU to the green transition. Verian. URL: <https://www.veriangroup.com/insights/eurobarometer/attitudes-of-citizens-in-the-eu-to-the-green-transition> [in English].
8. Khrupovych S. E. Implementation of world experience in the use of energy sources in the planning of cargo flows of urban transport. *Marketing support for the sustainable development of urban public transport*: monograph; under the editorship T. M. Borysova, G. L. Monastyrskiy. - Ternopil: Yu. V. Osadtsa, 2019. P. 141-158 [in Ukrainian].
9. EU to invest record €7 billion into sustainable, safe and smart transport infrastructure. [Press and information team of the Delegation to UKRAINE](#). 18.07.2024. URL: <https://www.eeas.europa.eu/delegations/ukraine/> [in English].
10. Net-zero electrical heat: A turning point in feasibility. URL: <https://www.mckinsey.com/capabilities/sustainability/our-insights/net-zero-electrical->

Combining science, education, and production as a way to form an effective mechanism for preventing climate change

[heat-a-turning-point-in-feasibility?str=CC5181D9B93B4BF2A412C16DCA1C8323&cid=other-eml-alt-mip-mck&hkid=1b98a35ca38e45259d3c3df4b36d958c&hctky=15667224&hdpid=6af1d11e-7bb9-4613-b492-9cea5f0696f0](https://doi.org/10.1016/j.jclepro.2019.117674) [in English].

11. David Ferreira Lopes Santos, Maitê Dubugras Valente Rezende, Leonardo Fernando Cruz Basso. Eco-innovation and business performance in emerging and developed economies, *Journal of Cleaner Production*. 2019. Vol. 237. DOI: <https://doi.org/10.1016/j.jclepro.2019.117674> [in English].

12. García-Granero E. M., Piedra-Muñoz L., Galdeano-Gómez E. Eco-innovation measurement: A review of firm performance indicators. *Journal of Cleaner Production*. 2018. Vol. 191. P. 304-317. DOI: <https://doi.org/10.1016/j.jclepro.2018.04.215> [in English].

SECTION 3.3 INTELLIGENT SYSTEMS FOR ASSESSING FUEL EFFICIENCY OF VEHICLES

Volkova Tatiana

Kharkiv National Automobile and Highway University, Ukraine

3.3.1 Current state of road transport in Ukraine

Road transport (RT) is the most important sector of the Ukrainian economy, serving virtually all sectors of the economy and population, and contributing to the growth of mobility and quality of life.

Currently, Ukraine's vehicle fleet includes more than 14 million vehicles, with the following structure: trucks - 15.5%, buses - 2.6%, and cars - 81.9% [1].

The automotive industry is one of the industries that started large-scale privatization in Ukraine. First and foremost, road transport enterprises (PJSCs) engaged in cargo transportation were privatized.

In this regard, a large number of carriers of various forms of ownership appeared on the market of road transport services, which had no experience in organizing transportation, the necessary professional knowledge, the appropriate technical base, and their vehicles did not meet the requirements of transportation safety.

The state transport policy in the industry is implemented through the laws of Ukraine, the regulatory and legal framework, and the regulatory and technical base, by improving the system of public administration and state regulation in the field of relations and activities of business entities.

The state regulation of the transportation services market is carried out through licensing of motor transportation activities. To date, the number of licenses obtained by legal entities and individuals in Ukraine is approximately 140 thousand, and the number of vehicles used by them is up to 400 thousand units. According to the Main

Combining science, education, and production as a way to form an effective mechanism for preventing climate change

State Inspectorate for Motor Vehicles, the share of carriers with only one vehicle in operation is 61%, up to three vehicles - 22.4%, up to five vehicles - 7%, up to ten vehicles - 5.4%, and more than ten vehicles - 4.3%.

The establishment of market relations in the public road transport system, privatization of state-owned PJSCs, purchase of vehicles for own funds or lease of vehicles led to the emergence of more than 30 thousand passenger carriers on the transportation services market, which received licenses for the right to provide passenger transportation services.

As of today, the bus service network includes about 19 thousand city, suburban, and international routes, with approximately 50 thousand buses. Prior to the transition to a market economy, the public transport system in Ukraine was operated by 45 to 54 thousand buses in different years, which were concentrated in 449 specialized state-owned PJSCs.

It should be noted that passenger road transportation is a technologically centralized system in which each vehicle must be under dispatcher control and management. As the experience of domestic and foreign carriers shows, the highest efficiency, quality and safety are achieved when vehicles receive the necessary technical and medical care, and buses are constantly monitored, when the transportation management system receives information about the location of the bus at certain intervals and can intervene in the transportation process.

Road transport continues to be the most resource-intensive and hazardous mode of transportation for the population and the environment.

Road transport consumes more than 6% of petroleum-based fuels, 7% of labor resources, and causes more than 96% of road accidents. Road transport is estimated to account for 40-5% of environmental pollution, including 60-7% in large cities and more than 85% in megacities. At the same time, at least 25% of the pollution is due to the technical condition of vehicles and the production activities of PJSCs [2].

The main systemic problems of JSCs at the present stage are [1]:

Combining science, education, and production as a way to form an effective mechanism for preventing climate change

- loss of administrative levers of management of the JSC as a fully privatized company;
- reduction in the volume of transportation work;
- unprofitable operation of passenger transport on public bus routes;
- massive aging of rolling stock and lack of mechanisms for its replacement;
- mismatch between the structure of the freight and passenger fleet and the demand for its services;
- unsatisfactory level of road transportation safety and significant economic burden on the environment.

3.3.2 Product life cycle and its information support

Today, the term “life cycle” (LC) is used in both natural and technical sciences, as well as in the humanities. Different subject dictionaries have a sufficient number of definitions of the LC, which are similar to each other in the main features [3].

The model of the full life cycle of an individual object is a description of the sequence of all phases, stages of its existence from conception and appearance (“birth”) to disappearance (“extinction”, Fig. 3.3.1).

The following main properties are characteristic of the full LC model:

- the structure (composition of stages) of the model of the LC does not depend on the object being described, i.e. the model of the LC is invariant with respect to changes in the type of object, industry, etc;
- in life, at any given time, there is only a process of activity of specific agents to create specific results, and this initial primary real process is fully described by the flows of the WT models.

A new technique for JSCs in the field of controlling their technical condition is the creation of information systems for organizational and functional support of car operation processes, through information integration: first, the stages of car LC, and second, systems of its technical control (control and diagnosis of car condition).

Combining science, education, and production as a way to form an effective mechanism for preventing climate change

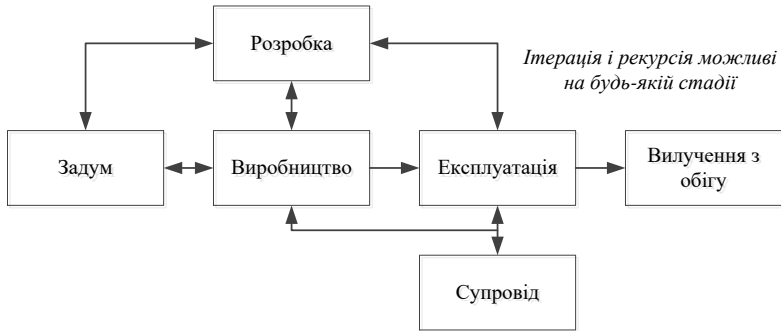

Figure 3.3.1 - Life cycle model (ukr)

The emergence of “systems with full responsibility” in transport, such as FADEC (Full Authority Digital Electronic Control system) [4], which is aimed at creating a single structure of on-board systems for controlling the work processes of units and assemblies, monitoring and diagnostic systems, systems for organizational and functional support of IPR / CALS / PLM technologies is a modern approach to the design, production and modern information technologies at all stages of the LCC [3, 4].

In the field of transport companies of JSC, the integrated information environment of IPR / CALS / PDM technologies is only being implemented. Today, it is only a set of networked electronic information systems in the form of distributed storages, which are heterogeneous, as they use different:

An example of the implementation in JSC is the Torque program as the basis of the “automotive” FADEC concept, which is the first step towards the FRACAS system and, accordingly, IPV / CALS / PLM technologies designed to receive and display diagnostic information from the onboard self-diagnostic system. Today, it already “knows” how to display the current parameters of the engine, the environmental component of the car, other systems, components and assemblies, display and decipher “error codes”, “erase errors” from the electronic control unit

Combining science, education, and production as a way to form an effective mechanism for preventing climate change

(ECU), automatically send the values of the parameters controlled by the sensor to the integrated electronic information meta-space, where within six months you can see not only the current values of the controlled values at different times, but also see on the map the entire route of the RS for this period [5].

3.3.3 Features of the use of information software systems

Based on the research carried out at KhNAHU, the transport information system of the virtual enterprise “KhNADU TESA” and the following information software systems (IS) “Virtual Mechanic ‘HADI-12’, IS ‘Service Fuel Eco ‘NTU-HADI-12”, IS “MonDiaFor ‘HADI-15’, IS ‘IdenMonDiaOperCon ‘HNADU-16”, which have the ability to work as part of intelligent transport systems (ITS), were developed [5, 6].

The formation of the technology for monitoring the technical condition of cars is based on a general approach to the study of the system “car - driver - operating conditions - car operating infrastructure (transport and highway)”, which includes the systematic interaction of the monitoring components: a car with a driver and an onboard information complex (OIC); car operating conditions (road, transport, atmospheric and climatic conditions, environmental and labor culture) [5]; transport infrastructure and infrastructure of the automobile industry.

As an example, we present the algorithm and some experimental results of the “Service Fuel Eco ‘NTU-HADI-12’ PKI. It has a separate block of the IPC “Environmental indicators” (Fig. 3.3.2), in which calculations are made in accordance with the methodology “Service Fuel Eco ‘NTU-HADI-12””. It determines the consumption of fuel, lubricants, emissions, and waste [6].

Average fuel consumption of a vehicle:

- when performing transportation work, l/100 km (m³/100 km, LNG);
- during maintenance and repair (5 % of fuel consumption during transportation), l.

Combining science, education, and production as a way to form an effective mechanism for preventing climate change

Lubricants consumption is shown in Table 3.3.1.

Table 3.3.1 - Consumption of lubricants in the Service Fuel Eco “NTU-HADI-12” IPC

Category of motor vehicle	Lubricant consumption, l/100 l (l/100 m3, LNG) (in relation to fuel consumption)			
	motor oil	transmission oil	specialty oils	plastic lubricants
M ₁	0,5...1,8	0,02...0,15	0,01...0,05	0,05...0,1
M ₂	0,5...1,8	0,02...0,15	0,01...0,05	0,05...0,1
M ₃	1,5...2,8	0,1...0,4	0,05...0,1	0,1...0,3
N ₁	0,5...1,8	0,02...0,15	0,01...0,05	0,05...0,1
N ₂	1,5...2,8	0,1...0,4	0,05...0,1	0,1...0,3
N ₃	1,5...2,8	0,1...0,4	0,05...0,1	0,1...0,3

Mass emissions of harmful substances (HM) are calculated according to formula 3.3.1, tons:

$$M_i = \sum_{m=1}^m g_{icj} G_j K_{Tikj} k_j, \quad (3.3.1)$$

where g_{icj} - the average specific emission of the i -th SR per unit mass of the j -th fuel type, kg/t;

G_j - the consumption of the j -th fuel by a car for a certain period, tons;

T_{ikj} - a coefficient that takes into account the impact of the technical condition of a vehicle of the k -th type consuming the j -th type of fuel on the value of specific emissions;

k_j - the coefficient of bringing the car to the environmental class.

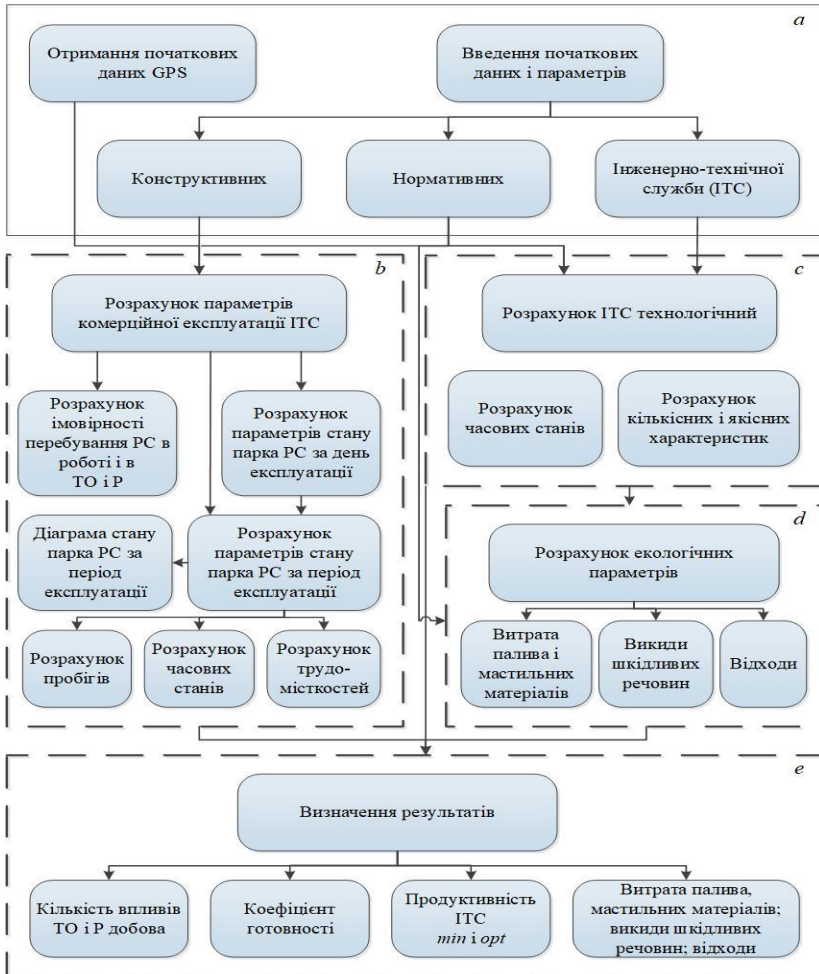

Figure 3.3.2 - Schematic diagram of the structural PKI “Service Fuel Eco ‘NTU-HADI-12’” (ukr)

The value of the correction factor T_{ikj} is selected depending on: the harmful substance (i) whose emission is calculated; type of vehicle (k) and type of fuel consumed (j), using the data in Table 3.3.2.

Table 3.3.2 - Values of T_{ikj} coefficients in the “Service Fuel Eco ‘NTU-HADI-12’ PKI

Vehicle category	Values of the T_{ikj} coefficient for different pollutants			
	CO	C_mH_n	NO_x	PM
M1	1,5	1,5	0,9	-
M2	1,7	1,8	0,9	-
M3	1,5	1,4	0,95	1,8
N1	1,7	1,8	0,9	-
N2	1,7	1,8	0,9	-
N3	1,5	1,4	0,95	1,8

Average specific emissions g_{icj} are selected from Table 3.3.3. The value of the average specific emissions of SR is given for the case when the car does not have exhaust gas neutralization systems (Euro 0). For environmental classes Euro 1 - Euro 6, the conversion factors k_j to the EURO standards are used (Table 3.3.4).

Table 3.3.3 - Values of average specific emissions of PM per unit of fuel consumed in the “Service Fuel Eco ‘NTU-HADI-12’”

Type of fuel	Specific emissions of pollutants kg/t of fuel			
	g_{CO}	g_{CH}	g_{NO_x}	g_{PM}
Gasoline	196,5	37,0	21,8	–
Liquefied petroleum gas	196,5	37,0	21,8	–
Diesel fuel	36,0	6,2	31,5	3,85
Compressed natural gas	87,5	22,4	27,6	–

Table 3.3.4 - Conversion factors to Euro kj

Pollutants	Ecological classes of cars						
	Euro-0	Euro-1	Euro-2	Euro-3	Euro-4	Euro-5	Euro-6
CO	1	0,4	0,32	0,17	0,12	0,12	0,1
NO _x	1	0,55	0,49	0,34	0,24	0,13	0,1
C _n H _m	1	0,46	0,46	0,28	0,2	0,2	0,15
PM	1	0,51	0,21	0,14	0,03	0,03	0,2

Waste at the motor vehicle transport facility includes batteries, tires, and filters. The amount of used batteries is determined based on the number of batteries installed on the vehicle (according to the road transport company), their service life and weight, units/year:

$$N = \sum_{m=1}^m N_{\text{avt}.i} \cdot n_i / T_i , \quad (3.3.2)$$

where $N_{\text{avt}.i}$ - the number of vehicles equipped with batteries of the i -th type, units;

n_i - number of batteries per vehicle, units;

T_i - the service life of the battery of the i -th type, year.

The weight of used batteries is equal to, t/year:

$$M = \sum_{m=1}^m N_i \cdot m_i \cdot 10^{-3} , \quad (3.3.3)$$

where N_i - the number of used batteries of the i -th brand, units/year;

m_i - the weight of the battery of the i -th type with electrolyte, kg.

The weight of used tires with a metal cord and with a fabric cord is determined by the formula, t/year:

$$M = \sum_{m=1}^m (L_i \cdot m_i \cdot N_i \cdot n_i) / (L_{ni} \cdot 10^{-3}), \quad (3.3.4)$$

where N_i - the number of cars of the i -th brand, units;

n_i - number of tires installed on the car of the i -th brand, units;

m_i - the weight of one worn-out tire of a given type, kg;

L_i - the average annual mileage of the car of the i -th brand, thousand km/year;

L_{ni} - the mileage rate of the car of the i -th brand before replacing the tires, thousand km.

The weight of used filters generated during the operation of the vehicle is determined by the formula, t/year:

$$M = \sum_{m=1}^m (L_i \cdot m_i \cdot N_i \cdot n_i) / (L_{ni} \cdot 10^{-3}), \quad (3.3.5)$$

where N_i is the number of vehicles of the i -th brand, units;

n_i - number of filters installed on the vehicle of the i -th brand, units;

m_i - weight of one filter on the vehicle of the i -th brand, kg;

L_i - the average annual mileage of the vehicle of the i -th brand, thousand km/year;

L_{ni} - the rate of mileage of the vehicle of the i -th brand before replacing the filters, thousand km.

An example of displaying information on the “Environmental Indicators Calculations => Costs” workspace is a wide range of parameters:

- state registration number of the vehicle
- vehicle group;
- fuel consumption during transportation work, l/100 km;
- fuel consumption during maintenance and repair, l;
- engine oil consumption, l/100 l (l/100 m³, LNG);
- transmission oil consumption, l/100 l (l/100 m³, LNG);
- special oil consumption, l/100 l (l/100 m³, LNG);
- consumption of plastic lubricants, l/100 l (l/100 m³, LNG).

To calculate emissions of harmful substances, select the window in the main menu: “Calculations of environmental indicators => Emissions”.

The information in the Emissions window can be sorted by state registration numbers of vehicles and by the date of receipt.

The following information is included in the emissions parameters:

- state registration number of the car;
- vehicle group;
- type of fuel;
- environmental class;
- mass emission of carbon monoxide, t;
- mass emission of hydrocarbons, t;
- mass emission of nitrogen oxides, t;
- mass emission of solid particles, tons.

To calculate waste, select the window in the main menu: “Calculations of environmental indicators => Waste”.

In the “Waste” window, you can sort the information by state registration numbers of the vehicle, date and type of emissions: used batteries; tires; filters.

3.3.4 Example of the results of fuel consumption by a car at driving distance sections using geofences

To determine the speed of the vehicle, taking into account the operating conditions, the experimental section of the road was divided depending on the formation of geozones along the entire distance of the road. First of all, we distinguished geozones of cities with a maximum speed limit of 50 km/h in accordance with the requirements of traffic rules and geozones outside the city with a maximum speed limit of 130 km/h.

The results of the study of fuel consumption by a car at the experimental sites within the travel distance - using the PKI "Service Fuel Eco 'NTU-HADI-12'" are shown in Fig. 3.3.3, and the changes in fuel consumption by a car while driving based on the results of processing the report in Fig. 3.3.4.

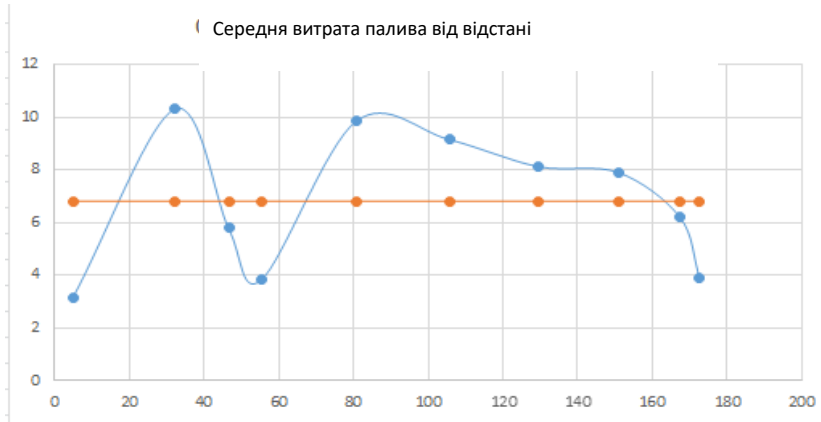

a

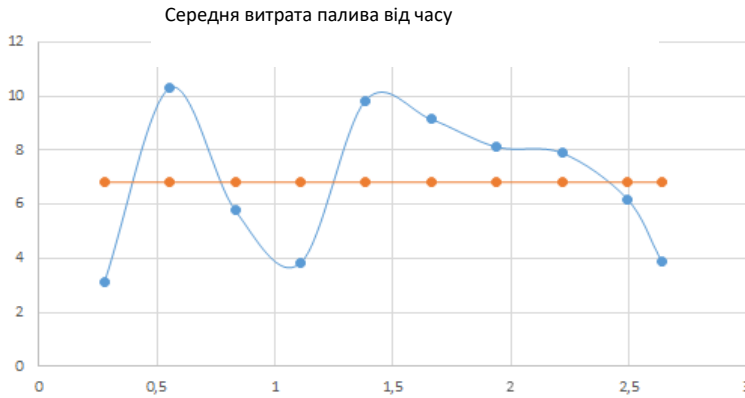

б

Figure 3.3.3 - Results of the study of fuel consumption by a car at the experimental sites within the travel distance: a - depending on the travel distance; b - depending on the travel time (ukr)

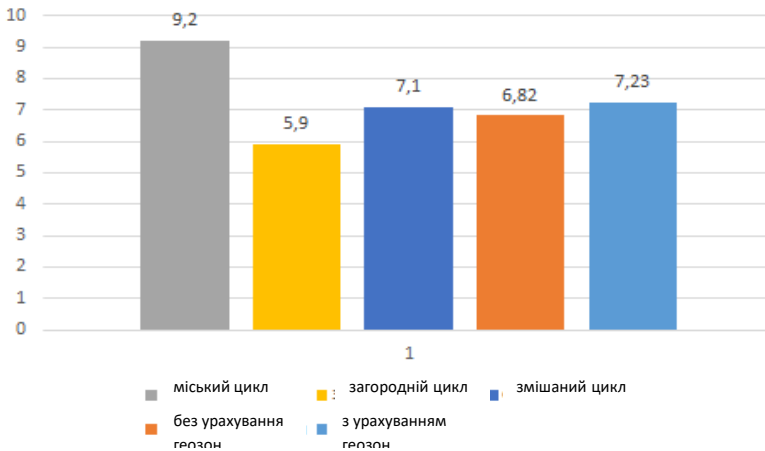

Figure 3.3.4 - Results of determining the change in fuel consumption by a car while driving based on the results of processing the report (ukr)

REFERENCES

1. State Statistics Service of Ukraine: Transport. Official website www.ukrstat.gov.ua: website. URL: https://www.ukrstat.gov.ua/operativ/menu/menu_u/tr.htm (accessed 04.07.2024).
2. Volkov V., Vnukova N., Taran I., Pozdnyakova O., Volkova T.. Influence of diesel vehicles on the biosphere / Scientific Visnyk of the National Hirnychiy Universytetu, 2021, No. 5. - P.94-99. (ISSN 2071-2227, E-ISSN 2223-2362, Scientific Visnyk of the National Hirnychiy Universytetu, 2021, No. 5. <https://doi.org/10.33271/nvngu/20215/094>) Scopus.
3. Monitoring of the technical condition of the car in the life cycle: textbook / V.P. Volkov et al: KHNADU, 2017. 301 c.
4. Intelligent systems for monitoring the technical condition of vehicles: textbook / Volkov V.P. et al: KHNADU, 2019. 264 c.
5. Volkov V., Gritsuk I., Taran I., Volkova T., Kuzhel V., Semenov A., Voznyak O.. Information Systems for Vehicles Technical Condition Monitoring. Data-Centric Business and Applications Lecture Notes on Data Engineering and Communications Technologies, 2024, pp. 61-96. https://doi.org/10.1007/978-3-031-54012-7_4
6. Software of transport monitoring systems: monograph / M.F. Dmytrychenko et al. Kyiv: NTU, 2016. 204 c.

CHAPTER 4
CLIMATE CHANGE AND THE
PROBLEM OF RESOURCE
CONSERVATION

Combining science, education, and production as a way to form an effective mechanism for preventing climate change

SECTION 4.1 SCIENTIFIC ASPECTS OF RESOURCE CONSERVATION MANAGEMENT AS A BASIS FOR CLIMATE CHANGE

Barun Marina

Kharkiv National Automobile and Highway University, Ukraine

Global climate change is perhaps the greatest challenge humanity has ever faced. It is a problem that our generation is already facing, and its consequences will be borne by future generations. Climate change is a reality

If current trends do not change in the coming years, global temperatures will reach their highest level by the end of the century. Scientists are convinced that climate change is human-influenced and that humanity is responsible for pollution and negative changes in the global climate balance. However, we are still unable to make quick decisions and are simply trying to cope with the consequences and adapt to the changes around us.

In the context of the crisis and transformation of the Ukrainian economy, the issue of managing resource-saving activities at an enterprise is of particular importance. Resource-saving activities are manifested not only at the enterprise level, but also have an impact on the industry and the economy as a whole by reducing the resource intensity of production and its more efficient operation. Therefore, the process of resource conservation not only contributes to the efficient operation of the company, but also to the effective management of the Ukrainian economy.

Considering serious environmental and resource issues from different angles, it can be said that the development of modern society is accompanied by the use of significant amounts of natural resources, while at the same time the destruction of the environment has reached a critical point. Due to the disruption of the relationship between nature and humanity, undesirable consequences are increasingly felt. Therefore, the application of resource-saving technologies, projects, etc. aimed at

Combining science, education, and production as a way to form an effective mechanism for preventing climate change

improving the situation with environmental pollution, releasing natural resources from production through the use of waste and secondary resources is relevant in the development of modern society.

Resource-saving activities are manifested not only at the enterprise level, but also have an impact on the industry and the economy as a whole by reducing the resource intensity of production and its more efficient operation. enterprises, industries and the economy as a whole, but also reduce the impact on the environment. The approach to the essence of the process of resource saving at the enterprise is shown in Fig. 4.1.1.



Figure 4.1.1 - The essence of the resource saving process at the enterprise

(ukr)

It should be noted that the process of resource saving can be considered both in a narrow and broad sense. In the first sense, resource conservation is the environment in which specific processes take place, i.e. activities aimed at achieving

Combining science, education, and production as a way to form an effective mechanism for preventing climate change

the specified results, namely, increasing the economic efficiency of production while reducing the use of resources. In a broad sense, the process of resource conservation covers all aspects of production and economic activity, both at the enterprise level and at the level of the industry and the state as a whole. It addresses issues arising from the interaction between the existing capabilities of the existing economic mechanism and the development and implementation of innovative resource-saving technologies in the production process.

Therefore, based on the above, the concept of resource saving has three manifestations, namely:

- 1) as a sphere of economic activity of society - an organisational and economic system;
- 2) as a process of rational use of all types of resources;
- 3) as a result, the sum of all types of effects.

It should be noted that when analysing approaches to defining the concept of resource efficiency, certain common features and differences were identified. For example, the ecological and production approach focuses on the use of new equipment and the introduction of the latest technologies in the production process, which will lead to a reduction in resource and energy intensity of products, while the ecological and resource approach focuses on the use of the latest zero- or low-waste technologies, the introduction of secondary resources and waste into production, which will lead to the rational use of resources and resource saving. The ecological and organisational approach considers organisational and technical measures to implement resource conservation in production.

The general classification of resource saving indicators by individual classification features and taking into account their nomenclature fixed at the state level is shown in Fig. 4.1.2.

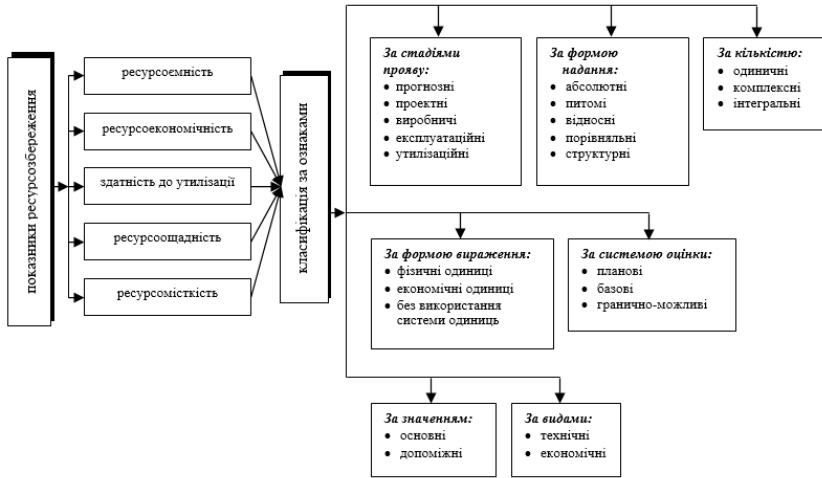

Figure 4.1.2 - Classification of resource saving indicators (ukr)

According to this classification, resource saving indicators are divided into the following categories:

- by type (technical and economic);
- by the stage of manifestation (forecasting - at the stage of research and development; design - at the stage of development work; production - at the stage of product manufacturing; operational - at the stage of application; disposal - at the stage of product liquidation);
- by the form of provision (absolute, specific, relative, comparative, structural);
- by the form of expression (in physical or economic units or without using a system of units);
- by the assessment system (planned indicators - for the future; basic indicators - established in interstate or state standards of Ukraine; actual indicators; maximum possible indicators - for each specific type of substance, materials, products, and articles);
- by value (primary and secondary);

Combining science, education, and production as a way to form an effective mechanism for preventing climate change

- by number (single - temporary; complex - group; integral - general).

Resource saving indicators help to assess the results of activities in this area. Direct results include those defined by internal goals, such as increased profits, reduced use of primary natural resources, reduced consumption of material resources, improved efficiency of the enterprise, etc. However, there are also indirect results (e.g., improvement of living conditions, environmental situation, landscape preservation, etc.) that cannot be assessed from an economic point of view.

The most convenient for standardisation, forecasting, comparative assessment and analysis are specific resource saving indicators, as they have a certain capacity, information content and can characterise the interdependence of heterogeneous parameters. The formulas for calculating specific resource saving indicators are determined by the product developer and, if necessary, used by qualified specialists from specialised organisations.

The carried out analysis of the theoretical foundations of formation of indicators of resource saving has shown that at the moment there is no single unified indicator of assessment of efficiency of resource saving at an enterprise.

A generalised indicator can be called the resource intensity of production P (4.1.1), which reflects the ratio of performance results to the costs of the enterprise that were spent to obtain maximum income [1].

$$P = \frac{ПC + IOB + \Phi B + BK + IB}{\Psi Д + IOД + ДК + I\Phi Д + ИД + НД}, \quad (4.1.1)$$

where, P - resource intensity of the enterprise;

$ПC$ - the total cost of goods sold;

IOB - other operating expenses;

ΦB - financial expenses;

BK - losses from equity participation;

Combining science, education, and production as a way to form an effective mechanism for preventing climate change

IB - other expenses;

ЧД - income from sales (goods, works, services);

IOД - other operating income;

ДК - income from equity participation;

ИФД - other financial income;

ИД - other income;

НД - extraordinary income (ukr)

The growth of resource saving opportunities is due to the transition to an intensive resource-saving type of economic development, reduction of material intensity of products, increase in labour productivity, improvement of technical and economic indicators and product quality. In particular, the modern development of technologies in the field of resource conservation can provide a production level that will allow to: reduce the specific consumption of raw materials and waste per unit of production; ensure the creation of a recycling system for secondary resources; reduce the extraction and use of primary raw materials; reduce the impact and minimise economic damage to the environment [2].

The main aspects of resource saving management at the enterprise in the context of climate change:

1. Energy efficiency: Implementation of energy-efficient technologies and practices, such as the use of renewable energy sources, modernisation of equipment, automation of production processes, and insulation of buildings to reduce heating and air conditioning costs.

2. Water resources management: Optimisation of water use, implementation of water reuse and purification technologies, reduction of water consumption in production processes.

3. Waste reduction: Establishing a waste management system that reduces the amount of waste generated, reuses or recycles it. For example, implementing *Combining science, education, and production as a way to form an effective mechanism for preventing climate change*

circular economy principles, where waste from one process becomes a resource for another.

4. Management of greenhouse gas emissions: Implementation of measures to reduce CO₂ and other greenhouse gas emissions, such as switching to clean energy sources, improving resource efficiency, and introducing new technologies.

5. Monitoring and reporting systems: Implementation of modern systems for monitoring resource use and emissions that allow the company to respond promptly to deviations from targets, as well as ensure transparency and accountability of the company's activities to stakeholders.

6. Staff education and training: It is important to provide employees with training on resource conservation, energy efficiency and sustainability. This will allow them to realise the importance of their actions and make suggestions for improving the efficiency of the enterprise.

7. Cooperation with suppliers and customers: It is important to build partnerships with suppliers and customers to work together to reduce resource consumption and environmental impact.

8. Innovative technologies and digitalisation.

9. The introduction of innovative technologies and digital solutions can significantly improve the efficiency of resource management. For example, the use of the Internet of Things (IoT) to monitor energy consumption in real time can help identify and quickly eliminate inefficiencies. Big Data analysis helps to predict resource requirements and optimise production processes.

10. Green certification and standards

11. Obtaining environmental certifications, such as ISO 14001 (environmental management system) and LEED (green building standards), can not only enhance a company's reputation but also provide access to new markets and customers who prefer environmentally responsible partners.

12. Adaptation to climate change: Businesses should develop strategies to adapt to climate change, taking into account risks such as sea level rise, extreme

Combining science, education, and production as a way to form an effective mechanism for preventing climate change

weather, and changing water resources. This may include redesigning production processes, strengthening infrastructure and changing suppliers.

13. Corporate social responsibility (CSR): The integration of CSR principles into the management of a business allows for the consideration of social and environmental aspects in business decision-making. This may include supporting local communities, participating in environmental protection programmes, and implementing social initiatives for employees and local residents.

14. Financial incentives and investments: Attracting investment in resource efficiency and climate adaptation projects can be supported by government programmes and international funds. For example, businesses can access green finance, which is provided for projects that reduce environmental impact.

15. Product life cycle assessment: Product Life Cycle Assessment (LCA) allows a business to understand the environmental impact of its products and services at all stages, from extraction of raw materials to disposal. It helps to identify key points for improving environmental performance and reducing resource consumption.

16. Cooperation with other companies and organisations: Cooperation with other companies, as well as participation in industry initiatives, can help an enterprise to share experiences and implement new practices. It also contributes to the development of joint projects aimed at resource conservation and environmental protection.

It is the resource efficiency strategy that interconnects, coordinates and directs actions between the innovative and environmental activities of an enterprise, resource-saving programmes and measures that take place at that enterprise and between existing legislative and regulatory documents.

The following innovation-oriented areas are the basis for the nature-based organisation of production activities when implementing a resource conservation strategy:

- Minimising the extraction of primary natural resources, with a focus on non-renewable and limited resources;

Combining science, education, and production as a way to form an effective mechanism for preventing climate change

- development and implementation of processes for the integrated processing of natural raw materials without generating waste (minimising waste generation at all stages of production);
- processing all types of production and consumption waste to produce secondary raw materials and marketable products;
- creating new types of products with a view to their possible reuse or environmentally friendly assimilation;
- use of closed industrial energy and water supply systems;
- commercial approach to waste disposal;
- creation of regional zero-waste technology parks and technopolises;
- creating a regional market for recycled materials and supplies;
- a cluster approach to the development of industries, including those focused on the recycling of materials [3].

Reducing material intensity, including material costs, can be achieved through the introduction of advanced scientific and technological advances.

In other words, a resource conservation strategy is a strategy aimed at significantly increasing the utilisation rate of raw materials and maximising the efficiency of all technological processes. Accordingly, an effective resource conservation strategy includes the following subordinate strategic directions:

- circularity, i.e. minimising waste and reducing the man-made impact on the environment through a closed loop of raw materials, secondary resources and waste;
- co-operation, i.e. a coordinated reduction of the negative impact on the environment by a set of enterprises that co-operate with each other to jointly solve environmental problems, save resources and minimise waste [4].

The resource conservation strategy determines the feasibility of a particular area of resource expenditure, guides the company's management to increase the number of implemented resource-saving measures and technologies, develop methods of analysis, forecasting, and stimulating the rational use of resources, which in turn will allow the company to effectively use all available reserves.

Combining science, education, and production as a way to form an effective mechanism for preventing climate change

The introduction and implementation of new resource-saving strategies by industrial enterprises will be facilitated:

- efficient economic, technological and environmental performance of the enterprise and overall systemic improvement of its operations;
- creating conditions for reducing waste generation and enhancing the rational use of all types of resources at the enterprise;
- improving organisational and economic measures to create an environmental management system;
- organising a system of continuous environmental monitoring of enterprises;
- certification and licensing of domestic enterprises in accordance with international environmental standards;
- creating modern systems for managing natural resources and the environment.

It is necessary to achieve maximum satisfaction of the needs of society with the minimum amount of production resources, which requires strengthening the economy regime at all stages of the production cycle, at all levels of the market economic system. That is why, in the context of constant competition, an enterprise cannot exist without rational use of the existing production apparatus, timely modernisation and replacement of labour tools, improved use of financial, material, labour and other resources, improvement of product quality, introduction of innovations, etc.

Since management of resource-saving activities is an integral part of the overall management of an enterprise, the application by domestic enterprises of effective measures and timely management decisions on resource saving and reduction of resource intensity of production will help in solving existing problems.

The main content of management activities in the context of resource saving at an enterprise is the direct implementation of resource saving management methods, namely, methods of management of functional systems, methods of performing management functions, mathematical methods, methods of statistics, expert methods, etc. The analysis of modern theoretical and methodological works in the field of

Combining science, education, and production as a way to form an effective mechanism for preventing climate change

resource saving has shown that at this stage there is no single method for managing such activities at industrial enterprises. Therefore, the correct application of the chosen method or several of them, their optimal combination and ratio will help in the effective management of resource saving at the enterprise. In addition, the correct choice and implementation of management decisions also depend on the chosen general scientific approach to management, namely: functional approach; parametric approach; target approach; process approach; system approach.

In general, each of these approaches includes a group of methods that are used (Fig. 4.1.3).

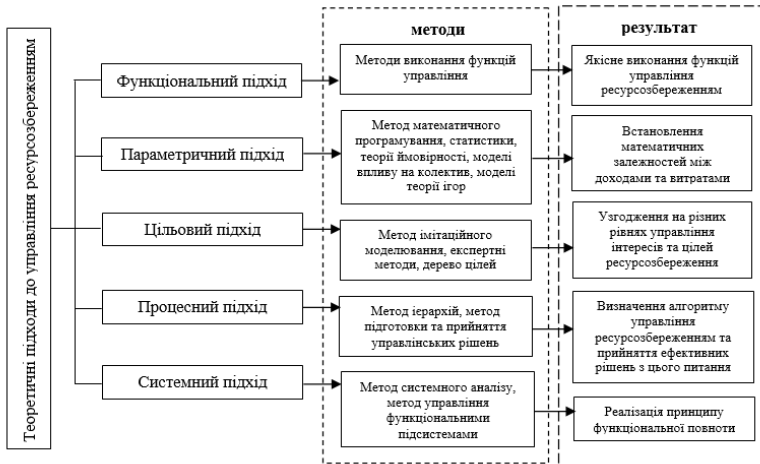

Figure 4.1.3 - Systematisation of resource saving methods and results depending on the management approach (ukr)

Since the process of resource saving is a complex phenomenon that penetrates into all areas of the enterprise's activity, we believe that the essence of resource saving management should be considered from the point of view of the system approach.

The process of forming a resource saving system at an enterprise involves several stages:

Combining science, education, and production as a way to form an effective mechanism for preventing climate change

- 1) Awareness of the need to save resources at the enterprise;
- 2) planning and organisation;
- 3) collecting and analysing data on technological processes and equipment, identifying priority indicators for data evaluation, recruiting qualified personnel, and developing possible alternatives;
- 4) analysis of the possibilities of implementing the proposed resource saving options;
- 5) Implementation of resource saving measures;
- 6) assessing the effectiveness of resource saving measures.

It should be noted that the proposed approach to the formation of a system for ensuring resource conservation at the enterprise and its management is based on the principle of functional completeness of the system, i.e., the system of resource conservation management at the enterprise is part of the overall enterprise management system, which includes: organisational structure; planning activities; duties and responsibilities; procedures, processes, resources for the formation, implementation, achievement, analysis, actualisation and optimisation of the policy of resource conservation implementation.

On the basis of the sequence of processes that determine the procedure for resource saving at an enterprise, the following algorithm for the formation and functioning of the resource saving management system is proposed (Fig. 4.1.4).

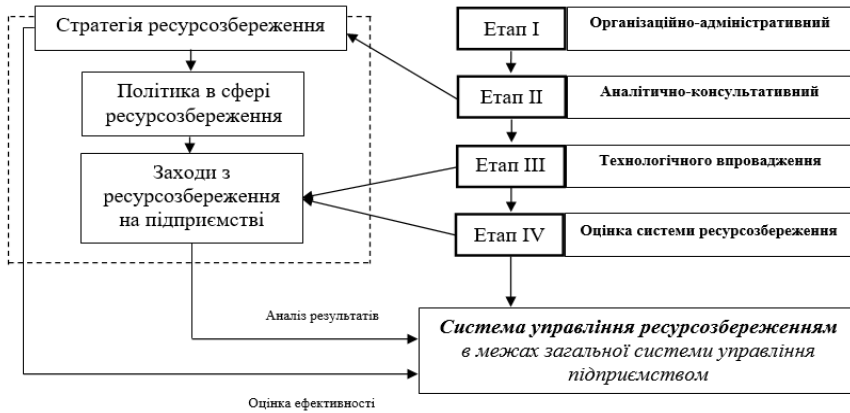

Figure 4.1.4 - Scheme of the algorithm of formation and functioning of the resource saving management system at the enterprise (ukr)

It should be noted that the first stage (Stage I) includes orientation of the enterprise towards fulfilment of the requirements set forth by the current legislative framework of Ukraine on environmental management, resource conservation and production waste management. Finding out the reasons for the high material intensity of production should be considered as a mandatory component of the material production management process. The results of accounting and analysis of key resource saving indicators, such as material intensity, resource consumption, resource efficiency, energy intensity and recyclability, will provide the information basis for making informed management decisions. We should also not forget about waste management and the possibility of using it in the production process as secondary resources, which, in turn, will allow us to competently organise the process of reducing production costs.

At the second, analytical and advisory stage (Stage II), the project documents on resource saving are analysed. Taking into account the identified areas, an appropriate resource saving strategy is developed at the enterprise, and a resource

saving management policy is determined, the purpose of which is to reduce the resource intensity of production.

At the stage of managerial decision-making on technological implementations (Stage III), managerial decisions are made on the implementation of resource saving measures at the enterprise.

At the fourth and final stage (Stage IV), the experience gained in the previous stages is systematised and accumulated, the effectiveness of the resource efficiency management system is assessed, and corrective decisions are developed and made.

Thus, the process of managing resource saving at an enterprise is characterised by the functions of general management, this process is independent, but at the same time is a subsystem of the general management of the enterprise. Taking into account the peculiarities of resource saving management and using the monitoring function, it is possible to analyse and control the indicators of resource saving at an enterprise, in particular, resource intensity, and, based on these indicators, make informed decisions on the management of resource saving activities.

Managing resource conservation at an enterprise in the context of climate change is a complex but necessary task. Implementation of a systematic approach to resource conservation helps to increase the competitiveness of the enterprise, reduce the risks associated with climate change, and promote sustainable development.

REFERENCES

1. Evaluation of the effectiveness of the enterprise management system [Electronic resource] / Selezneva G.O., Ippolitova I.Y. // *Effective Economy*. - 2020. - No. 3. - URL: <http://www.economy.nayka.com.ua/?op=1&z=7711>.
2. Sotnyk I.M. Economic bases of resource saving: Study guide / IM Sotnyk - Sumy: University book. 230 c.
3. BURKYNSKYI, B., LAIKO, O., SHLAFMAN, N., & GORYACHUK, V. (2021). COMPREHENSIVE PROVISION OF TECHNOLOGICAL POTENTIAL GROWTH IN THE ENTREPRENEURIAL SECTOR OF UKRAINE. *Economic Innovations*, 23(3(80), 11-20. [https://doi.org/https://doi.org/10.31520/ei.2021.23.3\(80\)](https://doi.org/https://doi.org/10.31520/ei.2021.23.3(80)).

Combining science, education, and production as a way to form an effective mechanism for preventing climate change

4. BURKYNSKYI, B., KHUMAROVA, N., & SHEVCHENKO, H. (2020). SOME ASPECTS OF STATE GOVERNANCE OF NATURAL ASSETS IN UKRAINE. *Economic Innovations*, 22(1(74), 8-19. [https://doi.org/https://doi.org/10.31520/ei.2020.22.1\(74\).](https://doi.org/https://doi.org/10.31520/ei.2020.22.1(74).)

CHAPTER 5

EDUCATIONAL AND PROFESSIONAL PROGRAM “ENVIRONMENTAL SAFETY” of the second (master's) level of higher education in the specialty 101 Ecology

*Combining science, education, and production as a way to form an effective
mechanism for preventing climate change*

ОСВІТНЬО-ПРОФЕСІЙНА ПРОГРАМА

«ЕКОЛОГІЧНА БЕЗПЕКА»

другого (магістерського) рівня вищої освіти
за спеціальністю 101 Екологія
галузі знань 10 Природничі науки
кваліфікація Магістр з екології

ЗАТВЕРДЖЕНО

Вченою радою ХНАДУ

Протокол № 55/23 від «30» червня 2023 р.

Голова Вченої ради



Віктор БОГОМОЛОВ

Освітня програма вводиться в дію з 1 вересня 2023 р.
наказ № 87 від «03» липня 2023 р.

Ректор



Віктор БОГОМОЛОВ

Харків 2023 р.

ПЕРЕДМОВА

1. Розроблено проектною групою:

Ганна ЖЕЛНОВАЧ, доцент кафедри екології ХНАДУ,
гарант ОП



Наталія ВНУКОВА, завідувач кафедри екології
ХНАДУ

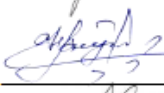

Олена ЛЕЖНЕВА, доцент кафедри екології ХНАДУ



Олександр ЛИТВИНЕНКО, голова Громадської
організації «Екологічна безпека регіонів України»

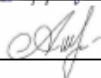

Яна ЄРЕМЄЄВА, Начальник Хіміко-радіологічної
лабораторії частини спеціальних рятувальних робіт
Аварійно рятувального загону спеціального
призначення ГУ ДСНС України у м. Києві



Юлія ГОРЕНКО, здобувач II рівня вищої освіти
(ДЕ-51-22), ХНАДУ



Олександра ЛЕБЕДЬ, здобувач II рівня вищої освіти
(ДЕ-51-22), ХНАДУ



Дар'я ОРЛОВА, здобувач I рівня вищої освіти (ДЕ-
31-20), ХНАДУ



2. Рекомендовано методичною комісією Дорожньо-будівельного
факультету

Протокол № 9 від «25» травня 2023 р.

3. Схвалено Методичною радою

Протокол № 8 від «07» червня 2023 р

4. Рецензенти:

– д.т.н., проф. Мирослав МАЛЬОВАНІЙ, завідувач кафедри екології
та збалансованого природокористування Інституту екології,
природоохоронної діяльності та туризму ім. В'ячеслава Чорновола
Національного університету «Львівська політехніка» (Україна)

– д.г.-м.н., проф. Тамерлан САФРАНОВ, завідувач кафедри екології та охорони довкілля Одеського державного екологічного
університету (Україна)

– к.т.н., доц. Теа КОРДЗАДЗЕ, керівник відділу забезпечення якості
Державного університету імені Акакія Церетеллі (Грузія)

1. ПРОФІЛЬ ОСВІТНЬОЇ ПРОГРАМИ

1 - Загальна інформація	
Повна назва закладу вищої освіти та кафедри, відповідальної за реалізацію ОП	Харківський національний автомобільно-дорожній університет Кафедра екології
Ступінь вищої освіти та назва кваліфікації мовою оригіналу	Магістр, Магістр з екології Master's degree, Master in Environmental studies
Офіційна назва освітньої програми	Освітньо-професійна програма «Екологічна безпека»
Тип диплому та обсяг освітньої програми	Диплом магістра, одиничний, 90 кредитів ECTS, термін навчання 1 рік та 4 місяці
Наявність акредитації	Акредитаційна інституція – Національне агентство із забезпечення якості вищої освіти, Україна Сертифікат про акредитацію – № 6485, прийнято рішенням НАЗЯВО, дата видачі сертифіката 14.12.2023 Акредитовано на період – з 14 грудня 2023 по 01 липня 2029 року
Цикл/рівень	HPK України – 7 рівень, FQ-EHEA – другий цикл, EQF-LLL – 7 рівень
Передумови	1. Наявність ОС «Бакалавр» зі спорідненої спеціальності 2. Наявність ОС «Бакалавр» зі неспорідненої спеціальності (зі складанням додаткового вступного випробовування)
Мова(и) викладання	Українська
Термін дії освітньої програми	до 2029 року
Інтернет-адреса постійного розміщення опису освітньої програми	https://www.khadi.kharkov.ua/education/katalog-osvitnikh-program/101-ekologija/
2 – Мета освітньої програми	
Метою програми є підготовка висококваліфікованих і професійних екологів, здатних вирішувати науково-професійні задачі та питання щодо зменшення рівня антропогенного впливу на природне середовище, розробки ефективних природоохоронних заходів, розв'язання практичних завдань у галузі екології та охорони навколишнього середовища, а також підготовка здобувачів з особливим інтересом до еколого-педагогічної, природоохоронної та просвітницької діяльності і до подальшого навчання.	

3 – Характеристика освітньої програми	
Предметна область (галузь знань, спеціальність)	<p>10 Природничі науки 101 Екологія</p> <p><i>Об'єкт:</i> структура та функціональні компоненти екосистем різного рівня та походження; антропогенний вплив на довкілля та оптимізація природокористування.</p> <p><i>Ціль навчання:</i> формування у здобувачів вищої освіти комплексу знань, умінь та навичок для застосування в професійній діяльності у сфері екології, охорони довкілля та збалансованого природокористування.</p> <p><i>Теоретичний зміст предметної області.</i> Поняття, концепції, принципи природничих наук, сучасної екології та їх використання для охорони навколишнього середовища, збалансованого природокористування та сталого розвитку.</p> <p><i>Методи, методики та технології.</i> Здобувач має оволодіти методами збирання, обробки та інтерпретації результатів екологічних досліджень.</p> <p><i>Інструменти та обладнання:</i> обладнання, устаткування та програмне забезпечення, необхідне для натурних, лабораторних та дистанційних досліджень будови та властивостей екологічних систем різного рівня та походження.</p>
Орієнтація освітньої програми	<p>Освітньо- професійна програма «Екологічна безпека» пропонує комплексний підхід до вирішення сучасних екологічних проблем на локальному, регіональному та національному рівнях. Дисципліни та розділи програми засновані на теоретичних знаннях, які тісно пов'язані з практичними навичками. Програма дозволяє здобувачам набути необхідних навичок в галузі екології, охорони навколишнього середовища та екологічної безпеки.</p>
Основний фокус освітньої програми та спеціалізації	<p>Акцент робиться на здобутті навичок та знань щодо забезпечення належного рівня екологічної безпеки на всіх рівнях, що передбачає здатність забезпечувати управління природоохоронною діяльністю, визначену зайнятість та можливість подальшої освіти та кар'єрного зростання.</p> <p>Передбачено поглиблені знання в галузі охорони навколишнього середовища та забезпечення екологічної безпеки на автомобільному транспорті й транспортній інфраструктурі, а також запобігання, адаптації та мінімізації наслідків зміни клімату.</p>

	Ключові слова: охорона довкілля, екологічна безпека, автомобільний транспорт, транспортна інфраструктура, зміна клімату, адаптація та мінімізація
Особливості програми	1. Забезпечується ефективне поєднання теоретичних знань та практичних навичок для підготовки висококваліфікованого фахівця із забезпечення екологічної безпеки в умовах неповноти інформації шляхом використання ризик-орієнтованого підходу. 2. Програма розвиває можливості та перспективи щодо практичного опанування навичок відносно запобігання, адаптації та мінімізації наслідків зміни клімату, що виникають внаслідок функціонування транспортного, енергетичного та промислового комплексів, з урахуванням міжнародного співробітництва.
Подальше навчання	Можливість навчання за програмою третього рівня вищої освіти (доктор філософії) та протягом життя
4 – Придатність випускників до працевлаштування та подальшого навчання	
Придатність до працевлаштування	2211.2 Еколог 2211.2 Експерт з екології 2213.2 Фахівець з екологічної освіти 1494 Менеджер (управитель) екологічних систем 2149.2 Науковий співробітник (галузь інженерної справи) 2310.2 Викладач університетів та вищих навчальних закладів
Подальше навчання	Можливість навчання за програмою третього рівня вищої освіти (доктор філософії) та протягом життя
5 – Викладання та оцінювання	
Викладання та навчання	Навчання за ОПП проваджується у контексті студентоцентрованості, проблемно-орієнтованого навчання через ефективне поєднання навчальних занять, самостійної роботи, практичної підготовки та контрольних заходів з одночасним створенням умов для ініціативного самонавчання.
Оцінювання	Оцінювання здобувачів ОПП відбувається згідно внутрішніх Положень ХНАДУ щодо організації освітнього процесу та контролю якості підготовки фахівців у відповідності до вимог стандарту вищої освіти 101 «Екологія» для другого (магістерського) рівня вищої освіти за 100-бальною шкалою, шкалою

	<p>ЄКТС та національною шкалою.</p> <p>Поточне оцінювання проводиться у формі семінарів, практичних робіт, проміжного тестування.</p> <p>Підсумкове оцінювання проводиться у формі письмового/усного екзамену або заліку, курсової роботи.</p>
6 – Програмні компетентності	
Інтегральна компетентність	<p>КІ. Здатність розв'язувати складні задачі і проблеми у сфері екології, охорони довкілля та збалансованого природокористування при здійсненні професійної діяльності або у процесі навчання, що передбачає проведення досліджень та/або здійснення інновацій, та характеризуються комплексністю і невизначеністю умов та вимог.</p>
Загальні компетентності (ЗК)	<p>ЗК01. Здатність вчитися і оволодівати сучасними знаннями.</p> <p>ЗК02. Здатність приймати обґрунтовані рішення.</p> <p>ЗК03. Здатність генерувати нові ідеї (креативність).</p> <p>ЗК04. Здатність розробляти та управляти проектами.</p> <p>ЗК05. Здатність спілкуватися іноземною мовою.</p> <p>ЗК06. Здатність до пошуку, оброблення та аналізу інформації з різних джерел.</p> <p>ЗК07. Здатність мотивувати людей та рухатись до спільної мети.</p>
Фахові компетентності спеціальності (ФК)	<p>ФК01. Обізнаність на рівні новітніх досягнень, необхідних для дослідницької та/або інноваційної діяльності у сфері екології, охорони довкілля та збалансованого природокористування.</p> <p>ФК02. Здатність застосовувати міждисциплінарні підходи при критичному осмисленні екологічних проблем.</p> <p>ФК03. Здатність до використання принципів, методів та організаційних процедур дослідницької та/або інноваційної діяльності.</p> <p>ФК04. Здатність застосовувати нові підходи до аналізу та прогнозування складних явищ, критичного осмислення проблем у професійній діяльності.</p> <p>ФК05. Здатність доводити знання та власні висновки до фахівців та нефахівців.</p> <p>ФК06. Здатність управляти стратегічним розвитком команди в процесі здійснення професійної діяльності у сфері екології, охорони довкілля та збалансованого природокористування.</p> <p>ФК07. Здатність до організації робіт, пов'язаних з</p>

	<p>оцінкою екологічного стану, захистом довкілля та оптимізацією природокористування, в умовах неповної інформації та суперечливих вимог.</p> <p>ФК08. Здатність до самоосвіти та підвищення кваліфікації на основі інноваційних підходів у сфері екології, охорони довкілля та збалансованого природокористування.</p> <p>ФК09. Здатність самостійно розробляти екологічні проекти шляхом творчого застосування існуючих та генерування нових ідей.</p> <p>ФК10. Здатність оцінювати рівень негативного впливу природних та антропогенних факторів екологічної небезпеки на довкілля та людину.</p> <p>ФК11. Здатність проваджувати діяльність щодо забезпечення екологічно збалансованого розвитку автомобільного транспорту та транспортної інфраструктури.</p> <p>ФК12. Здатність розробляти та реалізовувати комплекс робіт із запобігання, адаптації та мінімізації наслідків зміни клімату.</p>
7 – Програмні результати навчання	
<p>ПРН01. Знати та розуміти фундаментальні і прикладні аспекти наук про довкілля.</p> <p>ПРН02. Уміти використовувати концептуальні екологічні закономірності у професійній діяльності.</p> <p>ПРН03. Знати на рівні новітніх досягнень основні концепції природознавства, сталого розвитку і методології наукового пізнання.</p> <p>ПРН04. Знати правові та етичні норми для оцінки професійної діяльності, розробки та реалізації соціально-значущих екологічних проектів в умовах суперечливих вимог.</p> <p>ПРН05. Демонструвати здатність до організації колективної діяльності та реалізації комплексних природоохоронних проектів з урахуванням наявних ресурсів та часових обмежень.</p> <p>ПРН06. Знати новітні методи та інструментальні засоби екологічних досліджень, у тому числі методи та засоби математичного і геоінформаційного моделювання.</p> <p>ПРН07. Уміти спілкуватися іноземною мовою в науковій, виробничій та соціально-суспільній сферах діяльності.</p> <p>ПРН08. Уміти доносити зрозуміло і недвозначно професійні знання, власні обґрунтування і висновки до фахівців і широкого загалу.</p> <p>ПРН09. Знати принципи управління персоналом та ресурсами, основні підходи до прийняття рішень в умовах неповної/недостатньої інформації та суперечливих вимог.</p> <p>ПРН10. Демонструвати обізнаність щодо новітніх принципів та методів захисту навколишнього середовища.</p>	

ПРН11. Уміти використовувати сучасні інформаційні ресурси з питань екології, природокористування та захисту довкілля.	
ПРН12. Уміти оцінювати ландшафтне і біологічне різноманіття та аналізувати наслідки антропогенного впливу на природні середовища.	
ПРН13. Уміти оцінювати потенційний вплив техногенних об'єктів та господарської діяльності на довкілля.	
ПРН14. Застосовувати нові підходи для вироблення стратегії прийняття рішень у складних непередбачуваних умовах.	
ПРН15. Оцінювати екологічні ризики за умов недостатньої інформації та суперечливих вимог.	
ПРН16. Вибирати оптимальну стратегію господарювання та/або природокористування в залежності від екологічних умов.	
ПРН17. Критично осмислювати теорії, принципи, методи і поняття з різних предметних галузей для вирішення практичних задач і проблем екології.	
ПРН18. Уміти використовувати сучасні методи обробки і інтерпретації інформації при проведенні інноваційної діяльності.	
ПРН19. Уміти самостійно планувати виконання інноваційного завдання та формулювати висновки за його результатами.	
ПРН20. Володіти основами еколого-інженерного проектування та екологоекспертної оцінки впливу на довкілля.	
ПРН21. Застосовувати інноваційні та практичні підходи для забезпечення екологічно збалансованого розвитку автомобільного транспорту та транспортної інфраструктури.	
ПРН22. Уміти розробляти та реалізовувати комплекс робіт із запобігання, адаптації та мінімізації наслідків зміни клімату.	
8 – Ресурсне забезпечення реалізації програми	
Кадрове забезпечення	100 % науково-педагогічних працівників задіяних до викладання професійно-орієнтованих дисциплін зі спеціальності 101 «Екологія» мають наукові ступені та вчені звання.
Матеріально-технічне забезпечення	Обладнання та устаткування, необхідне для лабораторних і польових досліджень, технічні засоби навчання (мультимедійні проектори, ноутбуки, принтери, сканери) для формування предметних компетентностей в процесі навчання здобувача і необхідних в освітньому процесі, використання баз для проведення навчальних і виробничих практик в інших наукових, державних та комерційних установах (за договорами про співпрацю). Є навчальні аудиторії, лабораторії, комп'ютерні класи, гуржиток, пункти харчування, точки бездротового доступу до Інтернет, спортзали тощо. Навчально-методичне забезпечення і консультування до самостійної роботи здійснюється через

	використання підручників, конспектів лекцій, методичних вказівок, а також віртуального навчального середовища на платформі Moodle (https://dl.khadi.kharkov.ua/ та https://dl2022.khadi.kharkov.ua/).
Інформаційне та навчально-методичне забезпечення	Офіційний веб-сайт: https://www.khadi.kharkov.ua містить інформацію про освітні програми, навчальну, наукову і виховну діяльність, структурні підрозділи, правила прийому, контакти. Матеріали навчально-методичного забезпечення освітньо-професійної програми викладені на у віртуальному навчальному просторі ХНАДУ, ще реалізується за допомогою навчального сайту ХНАДУ на платформі Moodle : https://dl2022.khadi.kharkov.ua та https://dl.khadi.kharkov.ua . Читальні зали університету забезпечені бездротовим доступом до мережі Інтернет. Усі ресурси бібліотеки доступні через сайт університету: http://library.khadi.kharkov.ua . Участь наукової бібліотеки ХНАДУ у проєкті «Єдина картка читача» забезпечує систему взаємообслуговування у бібліотеках закладів вищої освіти міста Харкова
9 – Академічна мобільність	
Національна кредитна мобільність	Індивідуальна академічна мобільність реалізується у рамках міжуніверситетських договорів про встановлення науково-освітнянських відносин для задоволення потреб розвитку освіти і науки.
Міжнародна кредитна мобільність	На основі двосторонніх договорів між Харківським національним автомобільно-дорожнім університетом та університетами зарубіжних країн-партнерів. Участь у Програмі Еразмус+ КА1, КА2. Робота Кафедри ЮНЕСКО «Екологічно чисті технології» (409)
Навчання іноземних здобувачів вищої освіти	Можливе за умови володіння українською мовою.

2. ПЕРЕЛІК КОМПОНЕНТІВ ОСВІТНЬОЇ ПРОГРАМИ ТА ЇХ ЛОГІЧНА ПОСЛІДОВНІСТЬ

2.1 Перелік компонентів ОП

Код	Компоненти освітньої програми (навчальні дисципліни, курсові проекти (роботи), практики, кваліфікаційна робота)	Кількість кредитів	Форма підсумк. контролю
1	2	3	4
Обов'язкові компоненти ОП			
ОК 1	Іноземна мова	3	залік
ОК 2	Цивільний захист	3	залік
ОК3	Геоінформаційні системи в екології	3	екзамен
ОК 4	Екологічний менеджмент і аудит	4	екзамен
ОК 5	Технології кліматичного інжинірингу	6	залік, екзамен, курсова робота
ОК 6	Ресурсо- та енергозбереження	4	екзамен, курсова робота
ОК 7	Системний аналіз якості навколишнього середовища	7	екзамен, залік, курсова робота
ОК 8	Переддипломна практика	6	залік
	Виконання кваліфікаційної роботи	30	
Загальний обсяг обов'язкових компонентів:		66	
Вибіркові компоненти ОП			
ВД 1	Вибіркова дисципліна 1	4	залік
ВД 2	Вибіркова дисципліна 2	4	залік
ВД 3	Вибіркова дисципліна 3	4	залік
ВД 4	Вибіркова дисципліна 4	4	залік
ВД 5	Вибіркова дисципліна 5	4	залік
ВД 6	Вибіркова дисципліна 6	4	залік
Загальний обсяг вибірових компонентів:		24	
ЗАГАЛЬНИЙ ОБСЯГ ОСВІТНЬОЇ ПРОГРАМИ		90	

2.2 Загальноуніверситетський каталог вибірових дисциплін розміщено на офіційному сайті університету за посиланням

<https://www.khadi.kharkov.ua/education/katalog-vibirkovikh-disciplin/magistr/>

3 СТРУКТУРНО-ЛОГІЧНА СХЕМА ОП

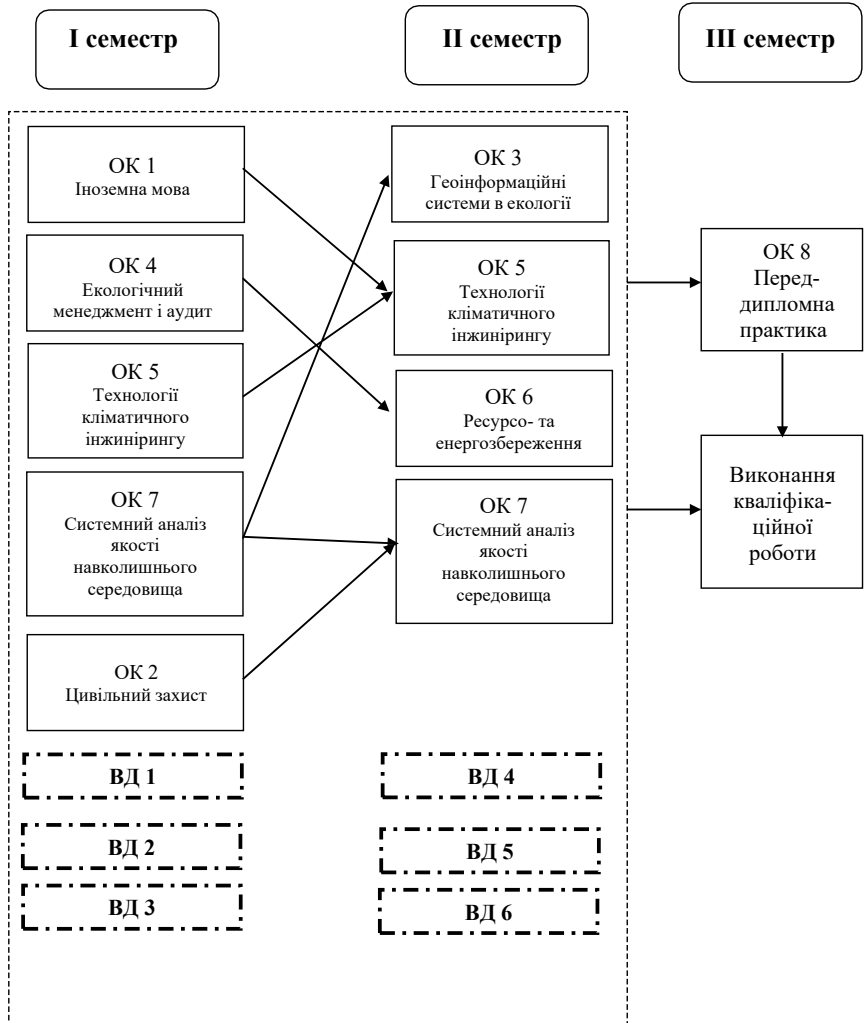

4. ФОРМА АТЕСТАЦІЇ ЗДОБУВАЧІВ ВИЩОЇ ОСВІТИ

Атестація здобувачів ОПП «Екологічна безпека» другого (магістерського) рівня вищої освіти, згідно стандарту вищої освіти за спеціальністю 101 «Екологія» для другого магістерського рівня вищої освіти відбувається у вигляді публічного захисту кваліфікаційної роботи та завершується видачою документів встановленого зразка про присудження ступеня освіти магістр та присвоєння здобутої кваліфікації «Магістр з екології».

Згідно Стандарту, кваліфікаційна робота повинна являти собою самостійне розв'язання комплексної проблеми у сфері екології, охорони довкілля та/або збалансованого природокористування, що супроводжується проведенням досліджень та/або застосуванням інноваційних підходів. Основні результати кваліфікаційної роботи мають бути апробовані, опубліковані та перевірені на плагіат. Кваліфікаційна робота має бути розміщена у репозитарії ХНАДУ.

Процедурні вимоги щодо проведення атестації здобувачів ХНАДУ закріплено у документі «Положення про організацію освітнього процесу в Харківському національному автомобільно-дорожньому університеті».

**5. МАТРИЦЯ ВІДПОВІДНОСТІ ПРОГРАМНИХ
КОМПЕТЕНТНОСТЕЙ КОМПОНЕНТАМ ОСВІТНЬОЇ ПРОГРАМИ**

	ОК1	ОК2	ОК3	ОК4	ОК5	ОК6	ОК7	ОК8
КІ			+	+	+	+	+	
ЗК01	+			+		+		
ЗК02		+	+		+	+	+	+
ЗК03		+	+		+			
ЗК04				+	+		+	+
ЗК05	+							
ЗК06			+			+	+	+
ЗК07	+			+				
ФК01			+	+		+	+	
ФК02					+	+	+	
ФК03				+				
ФК04			+			+		+
ФК05	+						+	
ФК06				+	+			+
ФК07		+	+		+		+	
ФК08	+	+			+		+	
ФК09		+		+	+			+
ФК10		+	+		+		+	
ФК11						+	+	
ФК12			+		+			

**6. МАТРИЦЯ ЗАБЕЗПЕЧЕННЯ ПРОГРАМНИХ РЕЗУЛЬТАТІВ
НАВЧАННЯ КОМПОНЕНТАМИ ОСВІТНЬОЇ ПРОГРАМИ**

	ОК1	ОК2	ОК3	ОК4	ОК5	ОК6	ОК7	ОК8
ПРН 1							+	
ПРН 2				+			+	
ПРН 3							+	
ПРН 4							+	
ПРН 5				+				+
ПРН 6			+					
ПРН 7	+							
ПРН 8	+							
ПРН 9				+				
ПРН 10		+			+	+		
ПРН 11			+				+	+
ПРН 12			+					
ПРН 13					+			+
ПРН 14		+			+			
ПРН 15					+		+	
ПРН 16				+				+
ПРН 17					+	+		
ПРН 18						+		
ПРН 19					+			+
ПРН 20							+	
ПРН 21						+	+	
ПРН 22			+		+			

7. МАТРИЦЯ ВІДПОВІДНОСТІ ПРОГРАМНИХ РЕЗУЛЬТАТІВ НАВЧАННЯ (ПРН) ТА КОМПЕТЕНТНОСТЕЙ

	К1	ЗК1	ЗК2	ЗК03	ЗК4	ЗК5	ЗК6	ЗК7	ФК1	ФК2	ФК3	ФК4	ФК5	ФК6	ФК7	ФК8	ФК9	ФК10	ФК11	ФК12
ПРН 1	+		+		+		+		+	+			+		+	+		+	+	
ПРН 2	+	+	+		+			+	+	+	+		+	+	+	+	+		+	
ПРН 3	+		+		+		+		+	+			+		+	+		+	+	
ПРН 4	+		+		+		+		+	+			+		+	+		+	+	
ПРН 5	+	+			+			+	+		+			+		+		+	+	
ПРН 6	+		+	+			+		+			+			+			+		+
ПРН 7																				
ПРН 8		+				+		+					+							
ПРН 9	+	+			+			+	+		+			+			+			
ПРН 10	+	+	+	+	+	+			+	+		+		+	+	+	+	+	+	+
ПРН 11	+		+	+	+		+		+	+		+	+		+	+		+	+	+
ПРН 12	+		+	+	+				+			+			+	+		+	+	+
ПРН 13	+		+	+	+					+				+	+	+	+	+	+	+
ПРН 14	+		+	+	+					+				+	+	+	+	+	+	+
ПРН 15	+		+	+	+					+				+	+	+	+	+	+	+
ПРН 16	+	+			+			+	+		+			+	+	+	+	+	+	+
ПРН 17	+	+	+	+	+		+		+	+		+		+	+	+	+	+	+	+
ПРН 18	+	+	+				+		+	+		+		+	+	+	+	+	+	+
ПРН 19	+		+	+	+					+				+	+	+	+	+	+	+
ПРН 20	+		+		+		+		+	+			+		+	+		+	+	
ПРН 21	+	+	+		+		+		+	+		+	+		+	+		+	+	
ПРН 22	+		+	+	+		+		+	+		+		+	+			+	+	+

Combining science, education, and production as a way to form an effective mechanism for preventing climate change

CHAPTER 6

CLIMATE CHANGE AND BIOENERGY

Combining science, education, and production as a way to form an effective mechanism for preventing climate change

SECTION 6.1 AGRICULTURAL RESIDUES AS A PROMISING SOURCE FOR BIOENERGY PRODUCTION

Mirko Barz,

Hochschule für Technik und Wirtschaft (HTW) Berlin, Germany

Biomass is the most important renewable energy source in use today. Renewable Energies contribute approx. 15 % to the global primary energy consumption and biomass remained steadily with share of 10% of the total primary energy consumption since 2000 [1], during at the same time an increase of the total primary energy consumption by approx. 30 % was registered. Considering the climate change as one of the main driver for the development of RE technologies advanced technologies to generate heat and power and the substitution from fossil fuels in the transportation sector are becoming more important.



Figure 6.1.1 – Total primary energy consumption by source (adopted from [2])

Many studies and scenarios predict a future potential contribution of biomass for energy production, resulting in a wide range of estimations. Numbers for a scenario for 2050 range up to 1,135 EJ annually [4], which would be equivalent to more than 100% of the expected primary energy demand in 2050. It's obvious that

Combining science, education, and production as a way to form an effective mechanism for preventing climate change

biomass has a high potential, e.g. annual growing biomass (theoretical potential) is equivalent to approx. 4,500 EJ, but in terms of using biomass in a sustainable way we have to consider technical, economic, ecologic and socioeconomic limitations. The “sustainable” useable potential is difficult to estimate or calculate. This is one of the reasons why predictions about the useable potential vary in a wide range.

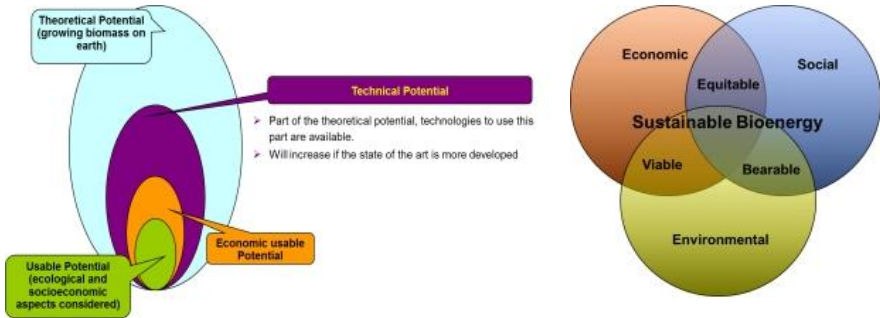

Figure 6.1.2 – Aspects of a sustainable biomass utilization, definition of potentials

Bioenergy (including the traditional use for cooking and heating) is the largest renewable energy source in use with a total contribution of about 58 EJ in 2020. Most of the bioenergy was provided from using woody biomass sources in traditional (e.g. fuelwood for heating and cooking) and advanced (e.g. CHP) applications.

Reason for the predominant use of woody biomass sources was in the past the high availability of this source, a comparatively high caloric value (18 – 20 MJ/kg), low ash contents (0.5 – 2%) and low contents of unwanted components such as sulphur or chlorine (table 6.1).

Combining science, education, and production as a way to form an effective mechanism for preventing climate change

Table 6.1.1 – Characteristics of woody biomass fuels (analysis results of various samples at TU Berlin 1998 – 1999)

Type of wood	C [%]	H [%]	O [%]	N [%]	S [%]	Cl [%]	Ash [%]	Ho [MJ/kg]
Pine	48 - 50	6 – 6.3	41 - 43	~ 0.2	~ 0.02	~ 0.01	0.5 - 1	18 – 20
Beech	49 - 51	6 – 6.1	41 - 44	~ 0.3	~ 0.01	~ 0.005	0.5 - 1	18 – 20
Poplar	47 - 48	6 – 6.2	42 - 44	~ 0.4	~ 0.03	~ 0.004	1 - 2	19 – 19
Willow	47 - 48	6 – 6.1	42 - 44	~ 0.5	~ 0.05	~ 0.006	1 - 2	18 - 19

Caused by favourable national support instruments, such as e.g. guaranteed feed in tariffs for biomass power in many countries the total amount of wood used for energy purposes is increasing continuously and in some regions, we recognize already a certain pressure to fuel supply security leading to increasing prices for fuel wood.

To reduce this pressure on woody biomass resources the use of agricultural residues as energy source is a promising opportunity. According to UNEP about 140 billion tons of biomass is generated every year from agriculture [3].

Many agricultural residues can potentially be used as bioenergy sources. The raw material base is diverse in form of e.g. stalks, straw, leaves, roots, husk or seed shells and farm- and animal husbandry waste. The properties of these biomass sources vary within a wide range. The most significant difference is between those residues that are predominantly dry (such as straw) and more suitable for thermochemical conversion routes (e.g. combustion, gasification, pyrolysis) and those that are wet (such as animal slurries) and more suitable for biological conversion routes (e.g. biogas production).

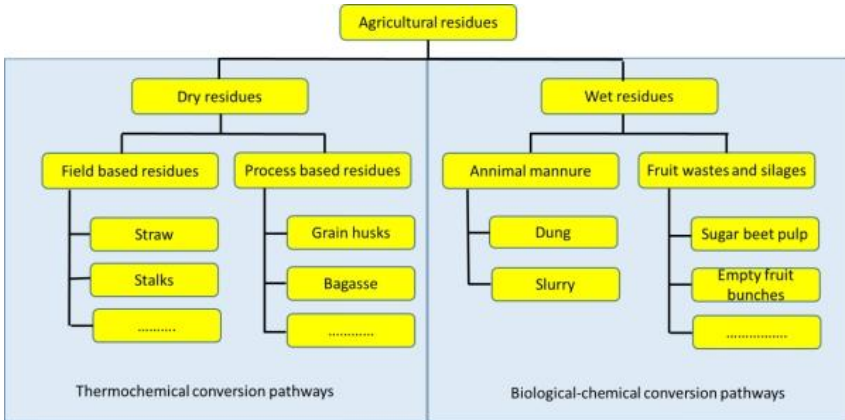

Figure 6.1.3 – Exemplary classification of agricultural residues

One of the most important advantages of using agro-wastes and residues as energy source is that such materials are often available in huge amount's and at low costs. Although this advantages are well known agro residues are still underutilized today. The common practice especially in developing countries is open field burning of dry residues (e.g. straw) which causes enormous air pollution or rotting of wet residues at the fields or dump sites which causes emission's, ground and water pollution.

A disadvantage is that many agricultural residues are only seasonal available (e.g. after harvest). Storage is required to ensure all season utilization and the energy density is often lower compared to woody fuels. In addition, the more difficult handling and partly high contents of critical components such as sulfur, chlorine, ash etc. (table 6.1.2) are barriers for the utilization.

Table 6.1.2 – Characteristics of dry agricultural residues as biomass fuels (adopted from [5])

Type of fuel	C [%]	H [%]	O [%]	N [%]	S [%]	Cl [%]	Ash [%]	Ho [MJ/kg]
Maize straw	45.7	5.3	41.7	0.65	0.12	0.35	6.7	16.7
Rape straw	47.1	5.9	40.0	0.84	0.27	0.47	6.2	18.4
Wheat straw	45.6	5.8	42.4	0.48	0.089	0.40	5.7	17.4
Sunflower straw	42.5	5.1	39.1	1.11	0.15	0.81	12.2	15.8

Especially for field based residues like straw as shown in table 2 the problematic fuel composition (high sulfur, chlorine and ash content) is combined with the limited seasonal availability (storage requirement), low transportation density (120 – 230 kg/m³ depending on the baling technology) and further disadvantages (storage risks, technological problems caused by low ash melting points etc.). The challenge is to adopt proven and robust technologies for other fuels into decentralized low capacity applications for the economic utilization of such critical fuels.

Agricultural residues are renewable resources that causes problems when not used but they can contribute to climate protection, energy security, creation of income and jobs especially in rural areas when they are converted into useful energy.

The generation of electricity from biomass encompasses a wide range of different possible conversion processes. The most important factors that influence the choice of conversion processes are the type of the biomass fuel and the fuel properties, the available quantity of biomass and as well environmental standards; economic conditions; and project specific factors [6]. This paper is considering only the thermochemical conversion route to generate heat and power via combustion and gasification processes.

The thermochemical conversion processes require fuels with high heating values and for this reason lower water contents of the biomass fuels. The most common process is the direct combustion of the fuels to produce thermal energy,

Combining science, education, and production as a way to form an effective mechanism for preventing climate change

which can be used e.g. for steam production and in further steps for electricity generation by using steam turbines, steam engines or other energy converter [7]. Further suitable thermochemical processes are gasification and pyrolysis processes, which will convert the biomass into so called secondary bio-fuels, such as combustible gases or oils as a fuel for gas engines and gas turbines to generate electricity. A promising advanced Biomass Power Generation concept for the future is the combination of gasification technologies with advanced gas turbines to biomass integrated gasification combined cycle (IGCC) concepts which will result in higher efficiencies compared to conventional Biomass Power Technologies. Net conversion to electricity is projected to be approximately 35% for biomass IGCC plants, compared to 20 to 25% for conventional biomass combustion plants [8]. IGCC is a proven concept for coal-based power generation (reaching electrical efficiencies up to 50% in large scale applications), but since up to now only large scale applications seem to be economic feasible, the conventional steam cycle processes will remain the most important technological solutions for the next years.

The conventional conversion technologies for solid biofuels by combustion have a great importance for the electricity generation. Most of the biomass power generation plants use direct fired systems, whereby the biomass is burned directly and the released thermal energy is used to produce steam leading to the generation of electricity via so called conventional steam cycle processes [10].

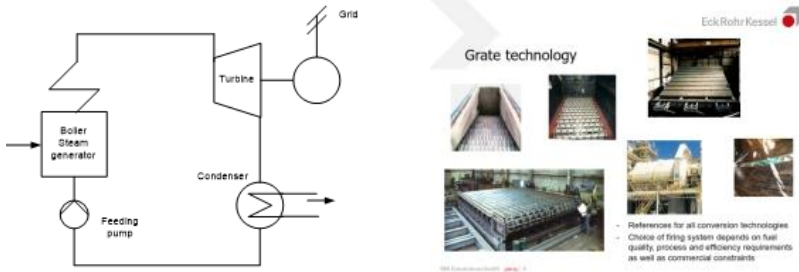

Figure 6.1.4 – Flow sheet diagram of conventional steam cycle for power generating and example grate technology

The combination of direct biomass combustion technologies, steam generators and power generation facilities like steam turbines, steam engines, steam screw engines and ORC systems is already established at market and the power range between 0,1 – max. 20 MW meets the requirements of the decentralized utilization of agricultural residues like e.g. straw or husks. Most of the systems (especially in the lower power range below 20 MW) are grate boilers, whereby the fuel is fed to the grate with the help of mechanical or pneumatic fuel feeders. The fuel is burned on the grate and the hot combustion gases are passing through heat exchanger to generate high pressure and high temperature steam to run a steam turbine (figure 6.1.4). Most of the biomass power plants are operated with relatively low temperature and pressure steam parameters (steam pressures of between 30-65 bar and temperatures between 450-485°C). Such systems can reach typical net electrical efficiencies between 20-25%, depending on plant capacities and steam parameters [10].

The challenge in case of using agro residues like straw in such systems is, that caused by the problematic fuel characteristic (table 6.1.2) straw fired biomass power plants require higher technological efforts to prevent ash agglomeration and/or corrosion. Especially Cl, S, K and Na in biofuels play a major role in deposit formation and corrosion mechanisms [11]. All of these elements can be found in significant higher concentrations in straw compared to wood. For this reason practice has shown that investment costs for straw fired power plants are up to 50% higher

Combining science, education, and production as a way to form an effective mechanism for preventing climate change

compared to wood fired power plants. Another obstacle is the more complex logistic process. As mentioned already caused by the limited seasonal availability enormous storage areas (a 10 MWe1 straw fired power plant will consume more than 100.000 t of straw/year) are required. The pre-conversion logistic is complex and includes collection, compacting/baling, field hauling/transportation, storage and further pretreatment before combustion. So beside higher investment costs also the costs for the logistic processes are higher. A long term profitable operation of straw fired power plants is only possible if the fuels supply is secured over a long timeframe (e.g. 20 years) at economic prices.

Another opportunity of the energetic utilization of dry agro-residues is the co-combustion in existing coal fired power plants. The biomass co-firing in coal-fired power plants offers significant advantages: it is highly efficient, approximately between 36% and 44%, depending on the efficiency of the coal-fired unit [9]. Such co-firing with coal is the most-simplest way to use biomass since an existing coal-fired power plant is used and this is more cost-effective than building a new power plant. Typical share of biomass in such co-firing systems is between 10-20 % contributing to the substitution of the coal and related environmental issues such as the mitigation of greenhouse gases [10].

Integrated gasification combined cycle power plants (IGCC) have been developed and demonstrated for power generation using fossil fuels such as coal as feedstock since many years [12]. Principle of the technological concept is the generation of burnable gases via a gasification process, the use of the burnable gas to run a gas turbine for electricity generation in a first power generation step and the further use of the hot flue gas from the gas turbine for steam generation, which will be used for electricity generation in a conventional steam cycle process as a second power generation step (figure 6.1.5).

The combination of both power generation processes (gas turbine + steam turbine) will result in an increased electrical efficiency (projected electrical

conversion efficiencies for biomass IGCC are above 35%) and reduced greenhouse gas emissions (figure 6.1.6).

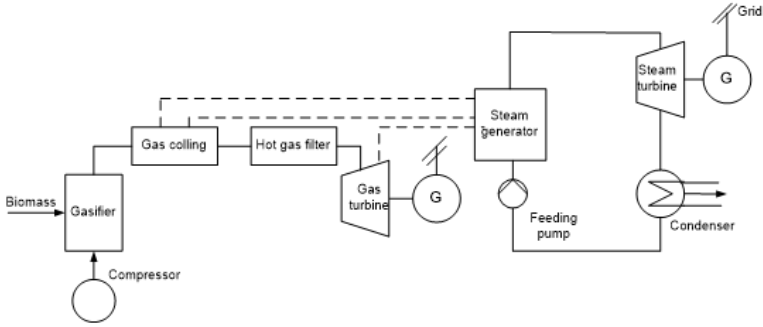

Figure 6.1.5 – Flow sheet diagram of biomass IGCC power plant

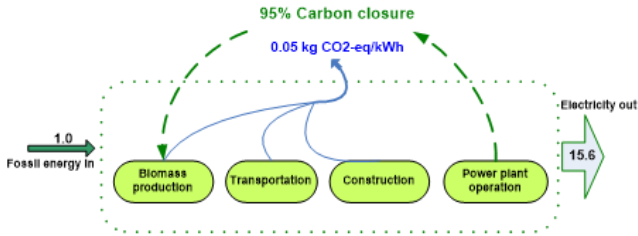

Figure 6.1.6 – Life cycle GWP balance for advanced biomass IGCC technology (adopted from Ref. [14]).

Biomass IGCC power generation process is technically viable as demonstrated at the Biomass IGCC project in Värnamo, Sweden. But critical issues are still the high necessary technological efforts as e.g. gas cleaning to ensure a long term reliable operation. The removal of tars, alkalis and PM is a great challenge for biomass IGCC facilities and high temperature methods to remove these compounds must be improved. Current research for biomass-derived syngas cleanup is focused on the

Combining science, education, and production as a way to form an effective mechanism for preventing climate change

catalytic cracking of tars, sintered metal candle filters for particulate removal, and high temperature alkali capture [8].

Further obstacles are, that IGCC facilities are more expensive to build than conventional direct fired power plants and that a limited reliability is currently being considered as the most important process-related problem of IGCC plants [13]. However, the further development of biomass IGCC is a central research focus of several R&D projects and a multitude of research institutions and commercial enterprises started extensive R&D efforts trying to solve the existing problems.

Biomass gasification is a thermo-chemical conversion process, aimed to convert solid biomass into a gaseous fuel, a so called syngas or burning gas (usually characterized by low caloric values between 4- 6 MJ/m³) which can be used in combustion engines or gas turbines or if burned in a conventional boiler to generate steam for steam turbines to generate electricity.

Most of the biomass gasification systems in use today are auto-thermal operated partial oxidation reactors, where just sufficient amount of air (typical excess air ration $\lambda \approx 0.25$) is introduced to the main reaction zone to burn a part of the biomass and to provide the required thermal energy for the endothermic pyrolysis and gasification processes. The reaction products are gaseous components such as CO, H₂, CH₄, CO₂, H₂O (representing the burning gag/syngas); solid products like char and ash and some condensable products such as tars and condensable vapors (unwanted components which have to be removed from the produced gas). A huge variety of gasification technologies, including fixed bed technologies such as updraft and downdraft gasifier, entrained flow gasifier and fluidized bed gasifier are available.

In most of the small scale applications (< 1 MWth) the biomass is gasified in a fixed bed (e.g. downdraft) gasifier, and the produced gas is then wet-scrubbed to condense tars and reduce syngas temperature and cleaned from particles. After such a comprehensive cleaning process the gas can be used in an internal combustion engine for power generation. In general gasification can handle a wide range of biomass

Combining science, education, and production as a way to form an effective mechanism for preventing climate change

fuels, ranging from woody residues to various agricultural residues. Biomass gasifier technologies combined with internal combustion engines are available at the market starting with very small scale applications (35 kW_{el} – 1 MW_{el}) but until now in the most cases only implemented for woody biomass fuels (caused by the favorable fuel characteristics of woody fuels). For agricultural residues such as straw, husks and other dry products only pilot or demonstration plants are in operation. Reason are the high efforts required to ensure a sufficient gas quality. A commercial implementation of gasification projects to use agro-residues with critical fuel characteristics requires that the still existing drawbacks such as system reliability, relatively high operation and maintenance costs (caused e.g. due to the necessary efforts to clean up the produced burning gas and to ensure a long term reliable performance of gas engines) have to be solved. But this technology might be a promising opportunity for the gasification of agricultural residues in the future, especially since gasification based CHP plants can be realized with lower capacities compared to conventional thermal power plants.

A promising and already successful implemented concept is the combination of biomass gasification and the use of the produced burning gas in conventional combustion system such as industrial gas boiler or as an alternative (renewable) fuel to substitute e.g. natural gas in cement kilns. In most cases the produced burning gas can be used without gas cleaning which makes the process more feasible by reducing the costs for investment and operation. The general principle is shown in figure 6.1.7 based on an example realized in Uruguay.

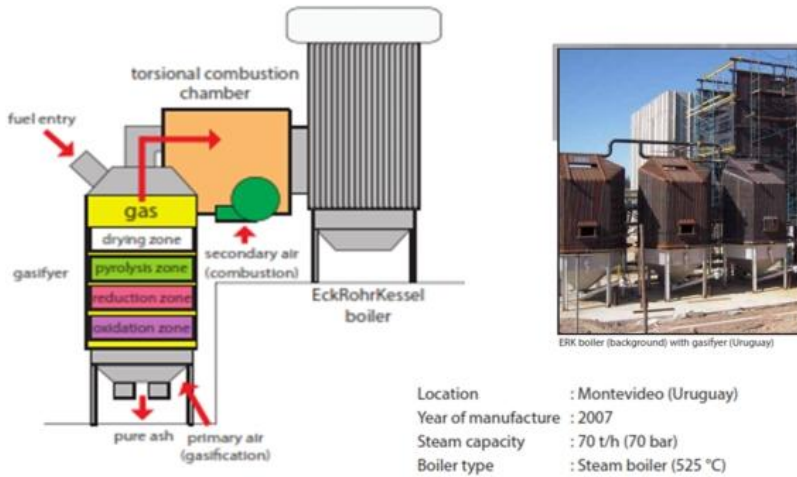

Figure 6.1.7 – Concept of biomass gasification and gas use in conventional boiler technologies

Fluidized bed gasification systems are more complex and for this reason more cost intensive than fixed bed gasification systems. The application area for fluidized bed gasification is thus more feasible for larger scale power generation projects (>3 MWe). In Thailand e.g. some test plants (prior to commercialized applications) are designed to use rice husk as biomass fuel. Drawbacks recognized until now is the poor gas quality and the high concentration of unwanted components such as tars and PM which might be caused by insufficient process control measures [10]. But as the high ash content, the low bulk density, poor flow characteristics and low ash melting point makes the other types of reactors inefficient or unsuitable for straw or husk conversion to energy, the fluidized bed reactor system seems to be the promising choice for this kind of fuel in the future [15]. Fluidized bed gasification systems could be especially a beneficial solution for locations where sufficient fuel amounts are available (e.g. byproducts of industrial processing of agricultural goods) and long distance transportation to existing power plants is unprofitable.

The author acknowledge the support received from the European Commission from the ERASMUS+ Program for the project "Synergy of educational, scientific,

Combining science, education, and production as a way to form an effective mechanism for preventing climate change

management and industrial components for climate management and climate change prevention (CLIMAN)”, project number: 619119-EPP-1-2020-1-NL-EPPKA2-CBHE-JP. The contents presented in this chapter is part of the activities to support the partner Universities to become centers for the development of research of climate management to accelerate integration into the global climate market and to meet global climate regulation requirements by acquiring best European practices in the field of climate change prevention, adaptation, and mitigation.

REFERENCES

1. REN21. 2015. Renewables 2015 Global Status Report (Paris: REN21 Secretariat), ISBN 978-3-9815934-6-4
2. IPCC 2011: Summary of the Special Report Renewable Energy Sources (SRREN), Intergovernmental Panel for Climate Change, Summary formally approved at the 11th Session of Working Group III of the IPCC, Abu Dhabi, United Arab Emirates. 5-8 May 2011.
3. UNEP 2009: Converting Waste Agricultural Biomass into a Resource, United Nations Environment Programme, 2009
4. Ladana, S; Vinterbäck, J. 2009: Global Potential of Sustainable Biomass for Energy, Swedish University of Agricultural Sciences, Report 013, ISSN 1654-9406, Uppsala 2009
5. FNR 2014: „Leitfaden Feste Biobrennstoffe“, 4., vollständig überarbeitete Auflage, Mai 2014, Fachagentur Nachwachsende Rohstoffe e. V. (FNR), Gülzow, ISBN 9783000153891
6. McKendry P, Energy production from biomass (part 2): conversion technologies, Bioresource Technology 83 (2002) 47–54
7. Barz M, Biomass Technology for Electricity Generation in Community, International Journal of Renewable Energy 3/1 (2008)

Combining science, education, and production as a way to form an effective mechanism for preventing climate change

8. Black & Veatch, Advanced biopower technology assessment, assessment report prepared for the Massachusetts Division of Energy Resources & Massachusetts Department of Conservation & Recreation (2008).

9. IEA ETSAP, Biomass for Heat and Power, Technology Brief E05 (2010) www.etsap.org

10. Barz, M; Delivand, M. K.: Agricultural Residues as Promising Biofuels for Biomass Power Generation in Thailand, Journal of Sustainable Energy and Environment, S. 21-27, 2011, ISSN 1906-4918

11. Obernberger, I; Brunner, T.; Bärnthaler, G.: Chemical properties of solid biofuels significance and impact; Biomass and Bioenergy, 30 (2006) 973 – 982

12. Stahl, K; Neergaard, M.: IGCC Power plant for biomass utilization, Varnamo, Sweden, Biomass and Bioenergy 15/3 (1998) 205-211

13. Liu H, Ni W, Li Z, Ma L, Strategic thinking on IGCC development in China, Energy Policy 36 (2008) 1–11

14. Spath, P.L.; Mann, M.K.: Biomass power and conventional fossil systems with and without CO₂ Sequestration – Comparing the energy balance, greenhouse gas emissions and economics (2004) NREL-Technical Report, NREL/TP-510-32575.

15. Natarajan E, Nordin A, Rao AN, Overview of combustion and gasification of rice husk in fluidized bed reactors, Biomass and Bioenergy 14/5-6 (1998) 33-546.

AUTHORS INFORMATION

Jan van Zwieten, Visiting professor BSK, Prof Dr.h.c., Rector of the Netherlands Business Academy, Netherlands

Mirko Barz, Doctor of Technical Sciences, Professor, University of Applied Sciences (HTW Berlin), Germany

Barun Maryna, PhD in Economics, Associate Professor, Kharkiv National Automobile and Highway University, Ukraine
ORCID: <https://orcid.org/0000-0002-6183-9462>

Bogachenko Galina, Director of International Projects Office of «KROK» University, Ukraine

Borysiak Olena, Doctor Science in Economics, Senior Lecturer of the Department of Transport and Logistics, West Ukrainian National University, Ukraine
ORCID: <https://orcid.org/0000-0003-4818-8068>

Vnukova Nataliia, Doctor of Technical Sciences, Professor, Head of the Department of Ecology at KhNAHU, member of the National Commission of Ukraine for UNESCO, Kharkiv National Automobile and Highway University, Ukraine
ORCID: <https://orcid.org/0000-0002-4097-864X>

Volkova Tetiana, PhD in Engineering, Associate Professor, Kharkiv National Automobile and Highway University, Ukraine
ORCID: <https://orcid.org/0000-0001-8546-4119>

Vronska Nataliya, C. Sc., Assoc. Prof., Associate Professor of Lviv Polytechnic National University, Ukraine, ORCID <https://orcid.org/0000-0002-6569-3288>

Darejan Jashi, Associate Professor, Batumi Shota Rustaveli State University, Georgia

Zhuk Volodymyr, C. Sc., Assoc. Prof., Associate Professor, Lviv Polytechnic National University, Ukraine ORCID <https://orcid.org/0000-0002-2275-0799>

Kozlovskiy Oleksandr, State Enterprise ‘Administration of River Ports’, Ukraine
ORCID <https://orcid.org/0000-0002-0256-8383>

Kochubei Viktoria, C. Sc., Assoc. Prof., Associate Professor of Lviv Polytechnic National University, Ukraine ORCID <https://orcid.org/0000-0003-1537-3953>

Combining science, education, and production as a way to form an effective mechanism for preventing climate change

Krasyuk Liudmyla, PhD in Agriculture, Senior Researcher, Scientific Secretary of the Institute of Agriculture of the National Academy of Sciences of Ukraine, ORCID: <https://orcid.org/0000-0001-9871-8253>

Lotariiev Andrii, Candidate of Science in Public Administration, «KROK» University, Ukraine ORCID <https://orcid.org/0000-0001-5852-231X>

Liuta Oksana, C. Sc., Assoc. Prof., Associate Professor of Lviv Polytechnic National University, Ukraine ORCID <https://orcid.org/0000-0001-9078-7457>

Malovanyy Myroslav, D. Sc. Tech., Prof., Lviv Polytechnic National University, Ukraine ORCID <https://orcid.org/0000-0002-3868-1070>

Narguli Asanidze, Associate Professor, Batumi Shota Rustaveli State University, Georgia

Nunu Nakashidze, Assistant Professor, Batumi Shota Rustaveli State University, Georgia

Prokopenko Nataliia, PhD in Biology, Associate Professor, Kharkiv National Automobile and Highway University, Ukraine ORCID: <https://orcid.org/0000-0001-5046-6122>

Tymchuk Ivan, C. Sc., Assoc. Prof., Associate Professor of Lviv Polytechnic National University, Ukraine ORCID <https://orcid.org/0000-0001-9344-3035>

Senyk Ivan, Doctor of Agricultural Sciences, Senior Researcher, Professor of the Department of Agribiotechnology, West Ukrainian National University, Ukraine ORCID: <https://orcid.org/0000-0003-4756-7824>

Giorgi Turmanidze, student, Batumi Shota Rustaveli State University, Georgia

Shmanko Nazar, PhD student, West Ukrainian National University, Ukraine ORCID: <https://orcid.org/0009-0009-4456-8224>

Shuvar Antin, Doctor of Agricultural Sciences, Head of the Department of Agribiotechnology, West Ukrainian National University, Ukraine ORCID: <https://orcid.org/0000-0002-6016-0896>

Shuvar Ivan, Doctor of Agricultural Sciences, Professor, Honored Worker of Science and Technology of Ukraine, Lviv National University of Environmental Management, Ukraine ORCID: <https://orcid.org/0000-0002-4149-1761>

Combining science, education, and production as a way to form an effective mechanism for preventing climate change

Shuvar Bohdan, PhD in Economics, Associate Professor, Lviv National University of Environmental Management, Ukraine
ORCID: <https://orcid.org/0000-0003-4722-8929>

Feshchenko Vasyl, Candidate of Agricultural Sciences, Associate Professor,
ORCID: <https://orcid.org/0009-0001-2199-8565>

CONTENT

INTRODUCTION.....	4
CHAPTER 1 Climate change and energy.....	8
Section 1.1 General issues of climate change impact on the energy sector.....	9
Section 1.2 Mesophilic anaerobic fermentation of broadleaf cattail suspensions utilizing fermented yeast production residues as a starter culture	23
Section 1.3 Wood processing by granulation to produce biofuels	39
CHAPTER 2 Climate change and agriculture	53
Section 2.1 Peculiarities of climate change impact on agricultural activities	54
Section 2.2 Increasing aridity of the growing season - challenges for farmers in Ternopil region	64
Section 2.3 Climate change and agriculture.....	69
Section 2.4 Agriculture in the context of global climate change: realities and prospects	74
Section 2.5 Climate change, intensive use of pesticides and their negative impact on citrus culture	86
CHAPTER 3 Climate change and the transportation system	91
Section 3.1 Climate change and the transport sector	92
Section 3.2 European transition to development of decarbonisation innovations in transport and logistics	101
Section 3.3 Intelligent systems for assessing fuel efficiency of vehicles	108
CHAPTER 4 Climate change and the problem of resource conservation.....	122
Section 4.1 Scientific aspects of resource conservation management as a basis for climate change	123

CHAPTER 5	Educational and professional program “Environmental safety” of the second (master's) level of higher education in the specialty 101 Ecology.....	138
CHAPTER 6	Climate change and bioenergy.....	154
	Section 6.1 Agricultural residues as a promising source for bioenergy production.....	155
AUTHORS INFORMATION.....		169

Scientific edition

**COMBINING SCIENCE, EDUCATION, AND
PRODUCTION AS A WAY TO FORM AN
EFFECTIVE MECHANISM FOR PREVENTING
CLIMATE CHANGE**

COLLECTIVE MONOGRAPH

Edited by N. Vnukova, N. Prokopenko

Submitted for printing on November 01, 2024. Signed for printing on November 07, 2024.

Format 60x84/16. Offset paper. Offset printing.

Times New Roman font. Mind. printing. sheet 24,25. Region-issue sheet 20.86.

Print run of 100 approx. Order No. 163. The price is negotiable.

Publisher: "Smugasta Typography",
61002, Kharkiv, st. Chernyshevska, 28A

Certificate of the subject of the publishing business: series DK No. 4863 dated 03/12/2015

Co-funded by the
Erasmus+ Programme
of the European Union



DISCLAIMER: The European Commission's support for the production of this publication does not constitute an endorsement of the contents, which reflect the views only of the authors, and the Commission cannot be held responsible for any use which may be made of the information contained therein.