

Міністерство освіти і науки України

ХАРКІВСЬКИЙ НАЦІОНАЛЬНИЙ АВТОМОБІЛЬНО-ДОРОЖНИЙ  
УНІВЕРСИТЕТ

Н. В. САЄНКО

## **ENGLISH FOR AUTOMOTIVE ENGINEERS**

*Навчальний посібник з англійської мови для студентів  
автомобільних спеціальностей*

Харків  
ХНАДУ  
2023

УДК 004=111  
С 12

*Рекомендовано Вченою радою Харківського національного  
автомобільно-дорожнього університету,  
дозвіл № 44/22/4.10 від 08 липня 2022 р.*

**РЕЦЕНЗЕНТИ:**

**О. Ю. Кузнецова**, доктор педагогічних наук,  
професор, завідувач кафедри іноземних мов № 3  
Національного юридичного університету ім. Ярослава Мудрого;

**О. Л. Ільєнко**, доктор педагогічних наук,  
професор, завідувач кафедри іноземних мов  
Харківського національного університету міського господарства  
ім. О. М. Бекетова;

**Н. В. Підбуцька**, доктор психологічних наук, професор,  
професор кафедри педагогіки і психології управління соціальними системами  
ім. академіка І. А. Зязюна Національного технічного університету «ХПІ»

**Саєнко Н. В.**

С 12 English For Automotive Engineers: навчальний посібник з  
англійської мови для студентів автомобільних спеціальностей.  
Харків: ХНАДУ, 2023. 96 с.

Метою посібника є навчання читання та розуміння професійно орієнтованих текстів з автомобільної галузі, засвоєння фахової лексики, формування навичок говоріння з широкого кола тем, пов'язаних із сучасними тенденціями розвитку автомобілів і автомобільної електроніки. Ефективне практичне вивчення мови забезпечується системою лексичних і комунікативних вправ, що стимулюють зацікавленість і творчу діяльність тих, хто вивчає мову.

Посібник призначений для студентів молодших курсів автомобільних спеціальностей.

УДК 004=111

© Саєнко Н. В., 2023  
© ХНАДУ, 2023

## CONTENTS

	ПЕРЕДМОВА	4
Unit 1	BRIEF HISTORY OF TRANSPORTATION	5
Unit 2	AUTOMOBILE	9
Unit 3	TYPES OF ENGINES	15
Unit 4	INTERNAL COMBUSTION ENGINE	21
Unit 5	POWER TRANSMISSION SYSTEM	25
Unit 6	ELECTRIC VEHICLES	29
Unit 7	CHALLENGES WHEN INTRODUCING ELECTRIC VEHICLES	34
Unit 8	HYBRID VEHICLES	38
Unit 9	HYBRID VEHICLES OPERATION MODES	42
Unit 10	FUEL CELL CARS	46
Unit 11	ELECTRICAL SYSTEM OF THE CAR	50
Unit 12	INTELLIGENT TRANSPORT SYSTEMS	54
Unit 13	FUTURISTIC VEHICLES	59
Unit 14	FLYING CARS	63
Unit 15	FUTURE TRENDS IN TRANSPORTATION	68
	ДІЯКА	87

## ПЕРЕДМОВА

Пріоритетною сферою інтересу й уваги у вищому технічному навчальному закладі є галузь науки та техніки.

Сучасний фахівець має бути підготовлений так, щоб іти в ногу з науково-технічним прогресом, мати повну інформацію про всі, зокрема новітні, досягнення у своїй галузі, уміти все це використовувати на практиці.

Наукове спілкування в сучасному світі відбувається здебільшого англійською мовою. Також переважна частина наукової інформації стає доступна англійською мовою, що останнім часом отримала статус міжнародної.

Для організації ефективного професійно орієнтованого спілкування й розуміння інформації з фаху необхідна спеціальна підготовка, що і є важливим завданням навчання іноземної мови у ЗВО. Одним із основних компонентів такої підготовки є вивчення наукової термінології відповідного фаху.

Прикладом професійно орієнтованих матеріалів є пропонований навчальний посібник з англійської мови «English for Automotive Engineers», що містить тексти з найрізноманітніших тем, пов'язаних з автомобільною галуззю. Посібник призначений для студентів молодших курсів технічних ЗВО, а також для широкого кола осіб, які вивчають і вдосконалюють англійську мову.

Кожен текст забезпечений набором до- і післятекстових завдань як лексичного, так і комунікативного характеру. Практична робота з цим посібником свідчить, що інформація, яка міститься у фахових текстах, викликає інтерес студентів освітніх закладів автомобільного профілю, а робота з поданим матеріалом може розглядатися як початковий етап навчання фахової англійської мови в технічному ЗВО відповідного напрямку.

Автор висловлює сподівання, що придбані студентами знання будуть використані в їхній майбутній професійній діяльності, розширять кругозір, підвищать рівень знань англійської мови.

# UNIT 1 BRIEF HISTORY OF TRANSPORTATION

## Word list:

1.	consider	розглядати	рассматривать
2.	distinction	відмінність	различие
3.	means of transport	транспортні засоби	транспортные средства
4.	exist	існувати	существовать
5.	milestone	віха, ключова подія	веха, ключевое событие
6.	crucial	ключовий, вирішальний	ключевой, решающий
7.	muscle power	м'язова сила	мышечная сила
8.	rowing	веслування	гребля
9.	sail	вітрило	парус
10.	energy source	джерело енергії	источник энергии
11.	steam	пара	пар
12.	impact	вплив	влияние
13.	approximately	приблизно	приблизительно
14.	internal combustion engine	двигун внутрішнього згорання	двигатель внутреннего сгорания
15.	gasoline	бензин	бензин
16.	fossil fuel	викопні види палива	ископаемые виды топлива
17.	crude oil	неочищена нафта	неочищенная нефть
18.	mankind	людство	человечество
19.	i.e.	тобто (від лат. id est)	то есть
20.	depletion	виснаження	истощение
21.	threat	загроза	угроза
22.	exhaust gases	вихлопні гази	выхлопные газы
23.	attempt	спроба	попытка
24.	emerge	виникати	возникать

## **Read and translate the text:**

### **BRIEF HISTORY OF TRANSPORTATION**

Considering transport, a distinction can be made between transportation over land using roads and railways, transport over seas and finally air transport.

Crucial for all means of transport is the fact that energy is needed. In ancient times, a lot of muscle power, by humans or animals, were used. When considering ships used to transport humans or goods over sea, traditionally a combination of muscle power (by rowing) and wind power (by using sail ships) has been used.

When considering the energy sources, a lot changed during the First Industrial Revolution. The use of steam engines had an important impact on the transportation sector. Steam ships and steam trains became very popular. Even steam driven cars have been developed. Approximately one century later, the development of internal combustion engines (e.g. using gasoline or diesel) also had a huge impact on the transportation sector.

Since the First Industrial Revolution, the use of fossil fuels has been very important. Coal is burned to produce the heat which is needed to produce steam. Gasoline, diesel and other fuels are produced based on crude oil. Also natural gas is a fossil fuel which can be used to drive e.g. a car. Unfortunately, the use of fossil fuels has a number of limitations and disadvantages. Mankind consumes fossil fuels much faster than nature can produce them i.e. depletion of fossil fuels is a threat. By burning fossil fuels, exhaust gases have a negative impact on the environment and the climate (e.g. global warming due to  $CO_2$ ).

Several attempts arise to reduce the use of fossil fuels, also when considering the transportation sector. Quite often, these attempts are linked with the introduction of (partially) electrically driven systems. So, the use of electric cars and hybrid cars is actually an emerging technology.

## Test Block

### Task 1. Match the parts of the words or word-combinations:

- |             |                      |
|-------------|----------------------|
| 1. muscle   | a. fuel              |
| 2. energy   | b. stone             |
| 3. mile     | c. oil               |
| 4. internal | d. kind              |
| 5. fossil   | e. power             |
| 6. crude    | f. gases             |
| 7. man      | g. combustion engine |
| 8. exhaust  | h. source            |

### Task 2. Match the words with close meaning:

- |                |               |
|----------------|---------------|
| 1. distinction | a. important  |
| 2. exist       | b. petrol     |
| 3. crucial     | c. danger     |
| 4. impact      | d. difference |
| 5. gasoline    | e. try        |
| 6. threat      | f. appear     |
| 7. attempt     | g. be         |
| 8. emerge      | h. influence  |

### Task 3. Match the parts of the sentences:

- |   |  |
|---|--|
| 1. Crucial for all means of transport is the fact | a. based on crude oil.                             |
| 2. The development of internal combustion engines | b. which is needed to produce steam.               |
| 3. Coal is burned to produce the heat             | c. than nature can produce them.                   |
| 4. Gasoline, diesel and other fuels are produced  | d. that energy is needed.                          |
| 5. Mankind consumes fossil fuels much faster      | e. had a huge impact on the transportation sector. |

**Task 4. Decide if the statements below are true (T) of false (F):**

1. A distinction can be made between transportation over land, seas and air. T/F
2. Internal combustion engines were developed approximately two centuries after the steam engine. T/F
3. The use of fossil fuels has a number of disadvantages. T/F
4. Exhaust gases have a positive impact on the environment and the climate. T/F
5. Several attempts arise to expand the use of fossil fuels. T/F
6. The use of electric cars and hybrid cars is actually an emerging technology. T/F

# UNIT 2

## AUTOMOBILE

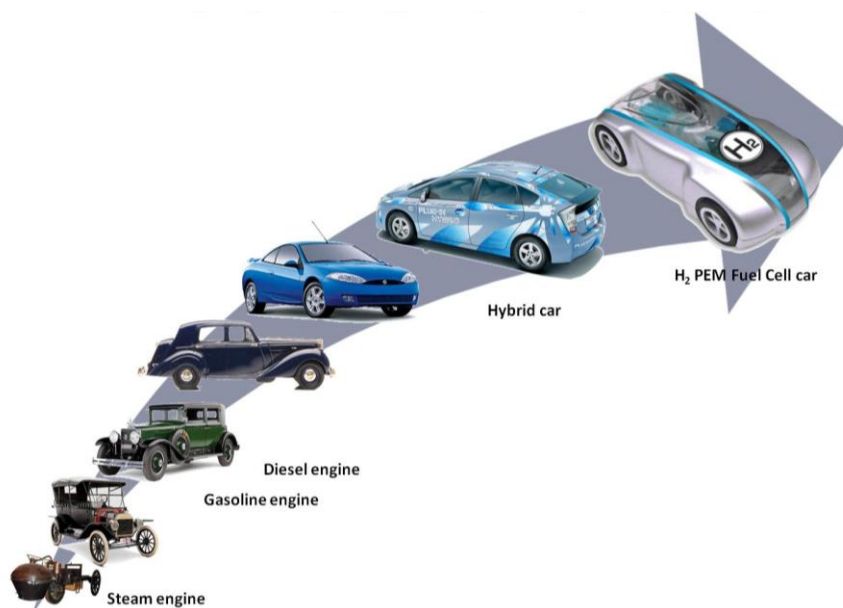

Fig. 1

### Word list:

1.	wagon	візок	повозка
2.	carriage	екіпаж, коляска	экипаж, коляска
3.	drive train	приводний механізм	приводной механизм
4.	gear differential	диференціал із шестернями	дифференциал с шестернями
5.	carburetor	карбюратор	карбюратор
6.	coolant system	система охолодження	система охлаждения
7.	chassis	шасі, ходова частина	шасси, ходовая часть
8.	frame	рама, каркас	рама, каркас
9.	steering system	рульове керування	рулевое управление

10.	suspension system	система підвіски	система подвески
11.	bumpy	вибоїстий, нерівний	ухабистый, неровный
12.	headlight	фара	фара
13.	interior	внутрішня частина	внутренняя часть
14.	dashboard	приладова дошка	приборная доска
15.	alternator	генератор змінного струму	генератор переменного тока
16.	body	кузов	кузов
17.	hood	капот	капот
18.	bumper	бампер	бампер
19.	grille	решітка (радіатора)	решетка (радиатора)
20.	trunk	багажник	багажник
21.	lid	кришка	крышка
22.	dial	показчик, циферблат	указатель, циферблат
23.	bucket seat	одномісне ковшоподібне сидіння	одноместное ковшеобразное сиденье
24.	bench seat	багатомісне неподілене сидіння	многоместное неразделенное сиденье
25.	leather	шкіра	кожа
26.	fabric	тканина	ткань
27.	fan	вентилятор	вентилятор
28.	seat belt	ремінь безпеки	ремень безопасности
29.	passive restraint	пасивний обмежувач	пассивный ограничитель
30.	airbag	подушка безпеки	подушка безопасности

## Read and translate the text:

### AUTOMOBILE

An automobile, autocar, motor car or car is a wheeled motor vehicle used for transporting passengers, which also carries its own engine or motor. Most definitions of the term specify that automobiles are designed to run primarily on roads, to have seating for one to eight people, to typically have four wheels, and to be constructed principally for the transport of people rather than goods.

The year 1886 is regarded the year of birth of the modern automobile – with the Benz Patent-Motorwagen, by German inventor Karl Benz. Motorized wagons soon replaced animal-drafted carriages, especially after automobiles became affordable for many people when the Ford Model T was introduced in 1908.

Automobiles are made up of many small components that form complex systems, all of which work together for you to drive the car.

*Drive Train.* The drive train is the system that generally makes your car move. It includes the engine, which burns fuel to produce the mechanical energy that moves the car, as well as the transmission, which changes the gear differential to use the power produced by the engine efficiently. It can also include the fuel system, consisting of the tank; various filters, fuel injectors or carburetors; the exhaust system, which removes the engine's waste products; the coolant system, which prevents the engine from overheating, and the braking system, which stops the car.

*Chassis.* The chassis of the car contains the skeletal frame of the car. The most notable components of the chassis are the steering system, which allows you to turn the wheels and change direction; the suspension system, which keeps the wheels on the ground, prevents a bumpy ride and stabilizes the steering; the frame that supports all the car's parts and keeps them together, and the wheels.

*Electrical System.* Many car components run on electricity. This includes the car computer, which micromanages many of the sensitive components, as well as the engine spark plugs, headlights, interior and dashboard lights, and stereo system. The car draws its electrical power from its battery, which is charged by the running engine via the alternator.

*Body.* Much engineering goes into designing the car body, which is composed of the metal, plastic or fiberglass pieces that cover the hood,

roof, doors and sides of the car. It also includes the bumpers, windows, grille and trunk lid. The design of the car body must attempt to minimize drag to increase fuel efficiency, as well as be aesthetically appealing to the driver.

*Interior.* The interior of a car also contains several important components. The dashboard and its various dials tell you the status of your car at any given moment, and no car would be complete without seats, whether they are bucket or bench seats, covered by leather or fabric. Most cars on the road today also include fans and ventilation for air conditioning and heat, as well as controls for those systems. No automobile would be considered safe without seat belts, and many, especially more modern, cars come with passive restraints, such as front and side passenger and driver airbags.

### **Test Block**

#### **Task 1. Fill in the gaps with the suitable words from the box:**

- a. fan
- b. hood
- c. tank
- d. trunk
- e. leather
- f. seat belt
- g. airbags
- h. carriages

1. One of the negatives about \_\_\_\_\_ car seats is the cost.
2. In hot weather we usually have to use a \_\_\_\_\_ for cooling the car.
3. He was fined by the police for not using a \_\_\_\_\_.
4. The indicator shows that the \_\_\_\_\_ has almost run out of petrol.
5. Earlier people were taken from place to place by \_\_\_\_\_ moved by horses.
6. The mechanic looked under the \_\_\_\_\_ to see what was wrong with the car.
7. There was no place for another suitcase in the \_\_\_\_\_.
8. All modern cars are equipped with \_\_\_\_\_ to prevent accidents.

**Task 2. Match the parts of the words or word-combinations:**

- |            |                 |
|------------|-----------------|
| 1. air     | a. board        |
| 2. bucket  | b. restraint    |
| 3. spark   | c. train        |
| 4. passive | d. light        |
| 5. drive   | e. differential |
| 6. head    | f. plug         |
| 7. gear    | g. bag          |
| 8. dash    | h. seat         |

**Task 3. Match the halves of the sentences:**

- |                       |   |
|-----------------------|---|
| 1. The engine         | a. removes the engine's waste products.   |
| 2. The exhaust system | b. consists of the tank, various filters, fuel injector or carburetors.               |
| 3. The transmission   | c. burns fuel to produce the mechanical energy that moves the car.                    |
| 4. The fuel system    | d. prevents the engine from overheating.  |
| 5. The coolant system | e. stops the car.   |
| 6. The braking system | f. changes the gear differential to use the power produced by the engine efficiently. |

**Task 4. Choose the one best answer to each question:**

- Which of the following is not the component of the chassis?
  - wheels
  - bumper
  - steering system
  - suspension system
- What is not included in the electrical system of the car?
  - spark plugs
  - dashboard lights
  - grille
  - computer

3. Which material is not used in designing the car body?
  - a. fabric
  - b. metal
  - c. fiberglass
  - d. plastic
4. Which is not referred to the car interior?
  - a. fan
  - b. seat belts
  - c. door
  - d. airbag

**Task 5. Sum up the information from the text answering the following questions:**

1. What is the automobile used for?
2. When was the first modern automobile constructed?
3. What five major systems do automobiles consist of?
4. What systems does the drive train include and what is their designation?
5. What are the most notable components of the chassis and what are they intended for?
6. What car components run on electricity?
7. What parts is the car body composed of?
8. What components does the interior of the car contain and what are they designed for?

## UNIT 3 TYPES OF ENGINES



Fig. 2

### Word list:

1.	convert	перетворювати	превращать
2.	motion	рух	движение
3.	internal combustion engine	двигун внутрішнього згорання	двигатель внутреннего сгорания
4.	external combustion engine	двигун зовнішнього згорання	двигатель внешнего сгорания
5.	pneumatic	пневматичний	пневматический
6.	oxygen, to oxidize, oxidizer	кисень, окислювати, окисник	кислород, окислять, окислитель
7.	expand, expansion	розширювати, розширювання	расширять, расширение
8.	combustion chamber	камера згорання	камера сгорания
9.	piston	поршень	поршень
10.	turbine blade	лопата турбіни	лопасть турбины

11. nozzle	форсунка, випускний отвір	форсунка, выпускное отверстие
12. heat exchanger	теплообмінник	теплообменник
13. pull in	втягувати	втягивать
14. air-breathing combustion engine	повітряно- реактивний двигун	воздушно-реактивный двигатель
15. stream	потік	поток
16. ignite	запалювати	воспламенять
17. expel	викидати, видаляти	выбрасывать, удалять
18. exhaust	вихлопний	выхлопной
19. interaction	взаємодія	взаимодействие
20. reverse	зворотний	обратный
21. pressurized	герметичний, під тиском	герметичный, под давлением
22. vehicle	транспортний засіб	транспортное средство
23. revolutions per minute	обертів за хвилину	оборотов в минуту

**Read and translate the text:**

**TYPES OF ENGINES**

An engine or motor is a machine designed to convert energy into useful mechanical motion. Heat engines, including internal combustion engines and external combustion engines (such as steam engines) burn a fuel to create heat, which then creates motion. Electric motors convert electrical energy into mechanical motion, pneumatic motors use compressed air.

*The internal combustion engine* is an engine in which the combustion of a fuel (generally, fossil fuel) occurs with an oxidizer (usually air) in a combustion chamber. In an internal combustion engine

the expansion of the high temperature and high pressure gases, which are produced by the combustion, directly applies force to components of the engine, such as the pistons or turbine blades or a nozzle, and by moving it over a distance, generates useful mechanical energy.

*An external combustion engine* is a heat engine where an internal working fluid is heated by combustion of an external source, through the engine wall or a heat exchanger. The fluid then, by expanding and acting on the mechanism of the engine produces motion and usable work. The fluid is then cooled, compressed and reused (closed cycle), or (less commonly) dumped, and cool fluid pulled in (open cycle air engine).

*Air-breathing combustion engines* are combustion engines that use the oxygen in atmospheric air to oxidize ('burn') the fuel, rather than carrying an oxidizer, as in a rocket. Theoretically, this should result in a better specific impulse than for rocket engines.

A continuous stream of air flows through the air-breathing engine. This air is compressed, mixed with fuel, ignited and expelled as the exhaust gas.

*An electric motor* uses electrical energy to produce mechanical energy, usually through the interaction of magnetic fields and current-carrying conductors. The reverse process, producing electrical energy from mechanical energy, is accomplished by a generator or dynamo.

The physical principle of production of mechanical force by the interactions of an electric current and a magnetic field was known as early as 1821. Electric motors of increasing efficiency were constructed throughout the 19th century, but commercial exploitation of electric motors on a large scale required efficient electrical generators and electrical distribution networks.

*A pneumatic motor* is a machine that converts potential energy in the form of compressed air into mechanical work. Pneumatic motors generally convert the compressed air to mechanical work through either linear or rotary motion. Pneumatic motors have found widespread success in the hand-held tool industry and continual attempts are being made to expand their use to the transportation industry.

*A hydraulic motor* is one that derives its power from a pressurized fluid. This type of engine can be used to move heavy loads or produce motion.

Besides, there is a category of hybrid vehicles that use two or more distinct power sources to move the vehicle. The term most commonly

refers to *hybrid electric vehicles*, which combine an internal combustion engine and one or more electric motors.

Engine speed is measured in revolutions per minute (RPM). Engines may be classified as low-speed, medium-speed or high-speed but these terms are inexact and depend on the type of engine being described. Generally, diesel engines operate at lower speed compared to gasoline engines.

### Test Block

#### Task 1. Match the words with close meaning:

- |    |            |    |             |
|----|------------|----|-------------|
| 1. | interactin | a. | outside     |
| 2. | expand     | b. | backward    |
| 3. | internal   | c. | movement    |
| 4. | reverse    | d. | dump        |
| 5. | motion     | e. | enlarge     |
| 6. | stream     | f. | inside      |
| 7. | expel      | g. | cooperation |
| 8. | external   | h. | flow        |

#### Task 2. Match the parts of word combinations:

- |    |             |    |            |
|----|-------------|----|------------|
| 1. | turbine     | a. | chamber    |
| 2. | heat        | b. | vehicle    |
| 3. | fossil      | c. | per minute |
| 4. | combustion  | d. | exchanger  |
| 5. | hybrid      | e. | gas        |
| 6. | revolutions | f. | fuel       |
| 7. | exhaust     | g. | blade      |

#### Task 3. Match the words with their definition:

- |    |            |    |  |
|----|------------|----|--|
| 1. | combustion | a. | a colourless highly reactive gaseous element   |
| 2. | nozzle     | b. | a disk or cylindrical part that fits into a larger cylinder and moves under fluid pressure |



- magnetic fields and current-carrying conductors
- d. is used to move heavy loads
  - e. converts potential energy in the form of compressed air
  - f. uses two or more power sources to move the vehicle
  - g. is widely used in the hand-held tool industry
  - h. the producing of energy is accomplished by a generator or dynamo
  - i. the fluid is cooled, compressed, reused or dumped and cool fluid is pulled in
  - j. usually fossil fuel is used in the process of combustion
  - k. compressed air is converted to mechanical work through either linear or rotary motion
  - l. mechanical energy is generated due to expansion of the high temperature and high pressure gases

# UNIT 4

## INTERNAL COMBUSTION ENGINE

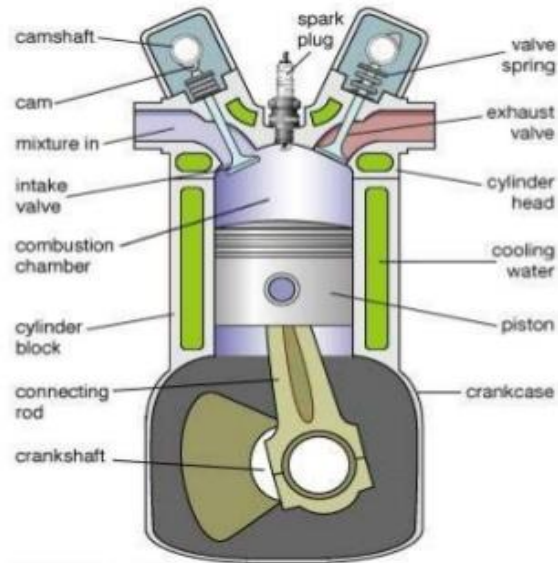

Fig. 3. Internal combustion engine

### Word list:

1.	enclosed	закритий	закрытый
2.	sealed	герметичний	герметичный
3.	space	простір	пространство
4.	vary	змінюватись, варіювати	меняться, варьировать
5.	motorcycle	мотоцикл	мотоцикл
6.	injector	інжектор	инжектор
7.	vaporize	випарювати	испарять
8.	function	функціонувати	функционировать
9.	stroke	хід	ход
10.	four-stroke	чотирикратний	четырёхтактный
11.	cycle	цикл	цикл
12.	induction	впуск	впуск
13.	intake	впуск	впуск
14.	port	отвір	отверстие
15.	spark plug	свіча запалювання	свеча зажигания
16.	explode	підривати	взрывать

## Read and translate the text:

### INTERNAL COMBUSTION ENGINE

Petrol and diesel engines are internal combustion engines. This means they are driven by the combustion (burning) of fuel in enclosed, sealed spaces called combustion chambers. In petrol and diesel engines, the combustion chambers are cylinders surrounded by a cylinder block and closed at the top by a cylinder head. Each cylinder contains a piston. The number of piston cylinders in an engine varies – engines in small motorcycles have only one, while sports car engines may have twelve.

Fuel is supplied to each cylinder from a tank. In most engines, the flow of fuel is generated by a pump, which forces it – at high pressure – through fuel injectors. These vaporize the fuel, allowing it to mix with air. Using this mixture (of fuel and air), most engines function as four-stroke engines. This means they work on a cycle of four stages – or four strokes. A stroke is an upward or downward movement of a piston.

The cycle of a four-stroke petrol engine looks like that:

*1. Induction or intake*

The intake valve open. The mixture enters the cylinder through a port (opening) in the cylinder head while the piston moves downwards.

*2. Compression*

The intake valve closes. The piston moves upwards, compressing the mixture.

*3. Power or ignition*

The spark plug produces a spark, which ignites (lights) the mixture. On ignition, the mixture explodes, generating a sudden pressure which forces the piston down.

*4. Exhaust*

The exhaust valve opens, and the piston moves upwards, forcing the exhaust gases – those produced during combustion – out of the cylinder via the exhaust port. The exhaust valve then closes and the cycle begins again.

## Test Block

### Task 1. Match the words with opposite meaning:

- |    |          |    |           |
|----|----------|----|-----------|
| 1. | function | a. | leaking   |
| 2. | sealed   | b. | fail      |
| 3. | enclosed | c. | be stable |
| 4. | intake   | d. | open      |
| 5. | vary     | e. | exhaust   |

### Task 2. Match the words with their definitions:

- |    |            |    |  |
|----|------------|----|--|
| 1. | space      | a. | a single completed movement                  |
| 2. | motorcycle | b. | a repeating series of actions                |
| 3. | stroke     | c. | a part of an engine that makes the fuel burn |
| 4. | cycle      | d. | the unlimited area                           |
| 5. | port       | e. | an opening body of an object                 |
| 6. | spark plug | f. | vehicle with two wheels and an engine        |

### Task 3. Choose the correct answers to the questions:

1. What is a combustion chamber?

- a. a cylinder
- b. a piston

2. Which vehicles have the biggest number of cylinders?

- a. the sport car
- b. the motorcycle

3. What generates the flow of fuel?

- a. a tank
- b. a pump

**Task 4. Describe the cycle of a four-stroke petrol engine arranging the following sentences in a proper order:**

1. *e*
- 2.
- 3.
- 4.
- 5.
- 6.
- 7.
- 8.
- 9.
- 10.

- a. The spark plug produces a spark, which ignites the mixture.
- b. The exhaust valve opens.
- c. The intake valve closes.
- d. The cycle begins again.
- e. The intake valve opens.
- f. The mixture explodes generating a sudden pressure which forces piston down.
- g. The mixture enters the cylinder through a port in the cylinder.
- h. The piston moves upward forcing the exhaust gas out of the cylinder.
- i. The exhaust valve closes.
- j. The piston moves upward, compressing the mixture.

# UNIT 5

## POWER TRANSMISSION SYSTEM

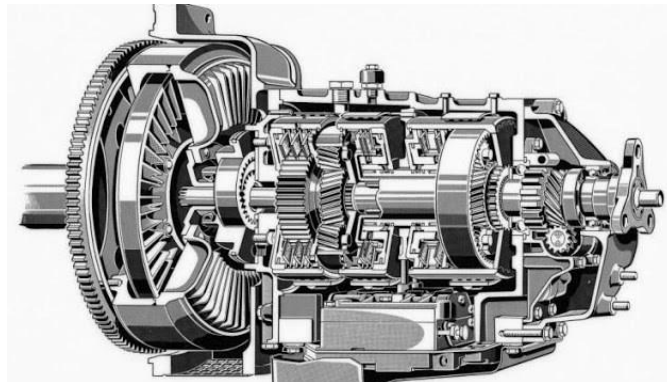

Fig. 4. Power transmission system

### Word list:

1.	power transmission system	силова трансмісія	силовая трансмиссия
2.	mechanical drive	механічний привод	механический привод
3.	mode	засіб	способ
4.	flexible	гнучкий	гибкий
5.	prime mover	двигун	двигатель
6.	friction drive	фрикційний привод	фрикционный привод
7.	mesh	зачеплення	зацепление
8.	belt drive	пасова передача	ременная передача
9.	worm gear	черв'ячна передача	червячная передача
10.	chain drive	ланцюгова передача	цепная передача
11.	coupling	муфта, з'єднання	муфта, соединение
12.	clutch	зчеплення	сцепление
13.	claw type coupling	кулачкова муфта	кулачковая муфта
14.	flanged coupling	фланцева муфта	фланцевая муфта

15.	by means of	за допомогою	посредством
16.	at will	за бажанням	по желанию
17.	friction clutch	фрикціон	фрикцион
18.	safety clutch	запобіжна муфта	предохранительная муфта
19.	gear	шестерня	шестерня
20.	gearing	зубчата передача	зубчатая передача

**Read and translate the text:**

**POWER TRANSMISSION SYSTEM**

A mechanical drive is a mechanism intended to transmit power from the prime mover to the machine. By the mode of transmitting motion from the prime mover, mechanical drives fall into the following types: a) transmission by friction with direct contact (friction drives) or a flexible connection (belt drives); b) transmission by mesh: with direct contact (toothed and worm gears) or with a flexible connection (chain drives).

Components of almost all machines used to transmit power both to and within a machine and connecting shafts are called couplings and clutches. Couplings may be divided into two groups: those of the fixed or rigid class and those of the flexible type. Rigid couplings may be exemplified by claw-type couplings, flanged couplings. The most widely spread flexible couplings are disk type and hydraulic-type ones.

A clutch is a kind of coupling, by means of which two shafts may be connected or disconnected at will. The most typical clutches are disk-type or cone-type friction clutches. To prevent any serious damage of a machine due to overloading safety clutches are used. A drive may also be formed by a series of two or more toothed wheels or gears which are meshed together to make a gearing.

## Test Block

**Task 1. Sort out the words by three categories to make appropriate word combinations:**

<i>Drive</i>	<i>Coupling</i>	<i>Clutch</i>
--------------	-----------------	---------------

- a. friction
- b. safety
- c. chain
- d. claw type
- e. belt
- f. mechanical
- g. flanged

**Task 2. Put the subtitles (A–C) in the same order as they are in the text:**

- 1.
- 2.
- 3.

- A. Clutches.
- B. A mechanical drive.
- C. Couplings.

**Task 3. Decide if the statements below are true (T) or false (F):**

- 1. A mechanical drive transmits power from the machine to the prime mover. T/F
- 2. There are two categories of mechanical drives. T/F
- 3. Coupling and clutches are components that transmit power to and within the machine. T/F
- 4. Two shafts are connected or disconnected by a coupling. T/F
- 5. Safety clutches prevent machines from serious damage. T/F

**Task 4. Match questions with answers:**

- |    |  |    |  |
|----|--|----|--|
| 1. | What two groups of couplings are there?                                  | a. | To transmit power from the prime mover to the machine.         |
| 2. | What is the purpose of safety clutches?                                  | b. | Couplings and clutches.  |
| 3. | How is a drive formed?   | c. | Fixed and flexible.  |
| 4. | What is a mechanical drive intended to?                                  | d. | To prevent any serious damage of a machine due to overloading. |
| 5. | What do we call components for transmitting power and connecting shafts? | e. | By a series of gears.  |

**Task 5. Speak on 1) mechanical drive; 2) coupling; 3) clutch according to the plan:**

1. purpose;
2. categories;
3. examples.

## UNIT 6

### ELECTRIC VEHICLES

#### Word list:

1. fleet	парк (автомобілів)	парк (автомобилей)
2. drivetrain	силова передача, трансмiсія	силовая передача, трансмиссия
3. alternative	варіант	вариант
4. arise	виникати	возникать
5. include	містити (у собі)	включать (в себя)
6. energy storage	накопичення й зберігання енергії	накопление и хранение энергии
7. solution	рішення	решение
8. in order to	для того, щоб	для того, чтобы
9. combine	поєднувати	сочетать
10. plug-in	підключається до електромережі	подключаемый к электросети
11. similar	подібний	подобный
12. power grid	енергетична система	энергетическая система
13. charge	заряджати	заряжать
14. range extended	зі збільшеним запасом ходу	с увеличенным запасом хода
15. traction motor	ходовий двигун	ходовой двигатель
16. imply	мати на увазі	подразумевать
17. fuel cell	паливний елемент	топливный элемент
18. instead of	замість	вместо
19. store	акумуляувати	аккумулировать
20. hydrogen	водень	водород
21. refuelling station	заправна станція	заправочная станция
22. conventional	стандартний	стандартный
23. gain importance	набувати більш важливе значення	приобретать все более важное значение

24.	perform research	проводити дослідження	проводить исследования
25.	increase	збільшувати	увеличивать

### **Read and translate the text:**

## **ELECTRIC VEHICLES**

In a lot of countries, an electrification of the fleet of cars is going on. When designing the drivetrain, several alternatives arise which includes the use of different energy storage solutions. Often, a distinction is made between six types of drivetrains.

- ICE: only an internal combustion engine is used to drive the car. At present, this is the most common type of drivetrain. It is also still the most common type of drivetrain used in newly sold cars.

- HEV: hybrid electrical vehicle. The drivetrain combines the use of a combustion engine and an electrical motor in order to combine the advantages of both technologies. Energy is stored using fossil fuels and a battery.

- PHEV: plug-in hybrid electrical vehicle. Similar with a HEV, the drivetrain combines the use of a combustion engine and an electrical motor. It is important the car can be connected with the electrical power grid which allows additional charging of the battery.

- REEV: range extended electrical vehicle. The car is only driven using an electrical traction motor fed by a battery. The battery can be charged using a plug-in connection with the electrical power grid. There is also an internal combustion engine which is used to drive an electrical generator which also allows to charge the battery (which feeds the electrical traction motor).

- BEV: battery electrical vehicle. The car is only driven using an electrical motor fed by a battery. There is no internal combustion engine implying the battery is charged using a plug-in connection with the electrical power grid.

- FCEV: fuel cell electrical vehicle. The car is only driven by an electrical motor i.e. there is no internal combustion engine. Instead of a battery, a fuel cell is used to feed the electrical motor. The energy is stored using hydrogen. By making a plug-in connection with the electrical power

grid, hydrogen can be produced. Alternatively, hydrogen can be bought at a hydrogen refuelling station.

At present, ICE based drivetrains are dominant but conventional HEV vehicles (e.g. the Toyota Prius) gain importance. When considering BEVs, the cars developed, manufactured and sold by Tesla are well known. But (almost) all car manufacturers perform research in the development of an increasing electrification of their drivetrains. The future of the market is unclear implying that different manufacturers have different opinions on that future.

### **Test Block**

#### **Task 1. Match the parts of the words or word-combinations:**

- |    |            |    |            |
|----|------------|----|------------|
| 1. | plug       | a. | to         |
| 2. | power      | b. | cell       |
| 3. | energy     | c. | importance |
| 4. | in order   | d. | research   |
| 5. | fuel       | e. | storage    |
| 6. | refuelling | f. | in         |
| 7. | gain       | g. | station    |
| 8. | perform    | h. | grid       |

#### **Task 2. Match the words with close meaning:**

- |    |              |    |             |
|----|--------------|----|-------------|
| 1. | alternative  | a. | decision    |
| 2. | include      | b. | analogous   |
| 3. | solution     | c. | suppose     |
| 4. | similar      | d. | accumulate  |
| 5. | imply        | e. | speed up    |
| 6. | store        | f. | contain     |
| 7. | conventional | g. | variant     |
| 8. | increase     | h. | traditional |

### Task 3. Fill in the gaps with the suitable words:

- a. combustion
- b. research
- c. common
- d. hydrogen
- e. battery
- f. grid

1. At present. Internal combustion engine is the most \_\_\_\_\_ type of drivetrain.
2. In a hybrid electrical vehicle the drivetrain combines the use of a \_\_\_\_\_ engine and an electrical motor.
3. In a range extended electrical vehicle the car is driven using an electrical traction motor fed by a \_\_\_\_\_ .
4. In a fuel cell electrical vehicle the energy is stored using \_\_\_\_\_.
5. Hydrogen can be produced by making a plug-in connection with the electrical power \_\_\_\_\_ .
6. Almost all car manufacturers perform \_\_\_\_\_ in the development of an increasing electrification of their drivetrains.

### Task 4. Match the type of the drivetrain with its description:

- |   |    |  |
|---|----|--|
| 1. ICE (internal combustion engine)         | a. | instead of a battery, a fuel cell is used to feed the electrical motor; the energy is stored using hydrogen  |
| 2. HEV (hybrid electrical vehicle)          | b. | the car is only driven using an electrical traction motor fed by a battery; there is also an internal combustion engine which is used to drive an electrical generator |
| 3. PHEV (plug-in hybrid electrical vehicle) | c. | only an internal combustion engine is used to drive the car  |

4. REEV (range extended electrical vehicle) d. The car is only driven using an electrical motor fed by a battery; there is no internal combustion engine; the battery is charged using a plug-in connection with the electrical power grid
5. BEV (battery electrical vehicle) e. the drivetrain combines the use of a combustion engine and an electrical motor in order to combine the advantages of both technologies
6. FCEV (fuel cell electrical vehicle) f. drivetrain combines the use of a combustion engine and an electrical motor; the car can be connected with the electrical power grid which allows additional charging of the battery

## UNIT 7

# CHALLENGES WHEN INTRODUCING ELECTRIC VEHICLES

### Word list:

1.	challenge	проблема, складне завдання	проблема, сложная задача
2.	introduce	упроваджувати	внедрять
3.	decent	пристойний	приличный
4.	mandatory	обов'язковий	обязательный
5.	sufficiently	досить	достаточно
6.	amount	кількість	количество
7.	weight	вага	вес
8.	proliferation	поширення	распространение
9.	range	діапазон, пробіг без дозаправки	диапазон, пробег без дозаправки
10.	discharge	розряджатися	разряжаться
11.	discourage	позбавляти бажання	отбивать желание
12.	behaviour	поведінка	поведение
13.	due to	через	из-за
14.	decrease	зменшувати	уменьшать
15.	require	вимагати	требовать
16.	effort	зусилля	усилие
17.	option	можливий варіант	возможный вариант
18.	self-heating	саморозігрівальний	саморазогревный
19.	lithium-ion	літій-іонний	литий-ионный
20.	ambient	зовнішнє середовище	внешняя среда
21.	obtain	отримувати	получать
22.	share the opinion	погоджуватися з думкою	разделять мнение
23.	improvement	поліпшення	улучшение
24.	reduction	скорочення	сокращение
25.	emission	викид	выброс

## **Read and translate the text:**

### **CHALLENGES WHEN INTRODUCING ELECTRIC VEHICLES**

Introducing an electric fleet of cars has some challenges.

The development of decent batteries is mandatory. Batteries must be able to store a sufficient amount of energy and the weight must be acceptable.

A decent electrical grid infrastructure implies a proliferation of charging stations.

A large number of different battery technologies exist. Whatever battery technology has been used, the car drivers

- need a sufficiently large range (the fear that the battery will be discharged before reaching the destination, discourages the use of electric vehicles),
- need fast charging stations (e.g. with charging powers up to 350 kW, a 60 kWh battery can be charged in approximately 10 minutes),

Reaching this large range and realising a fast charging behaviour is especially a challenge in case of cold weather. Due to the low temperatures, the range decreases and the required charging time increases. Efforts are made to develop so-called all-climate battery technology to have a sufficiently large range and a sufficiently small charging time.

One option of the all-climate battery is a self-heating lithium-ion battery. This battery can warm up rapidly (e.g. needing only tens of seconds) from the low ambient temperature to room temperature. Once warmed up, the desired large range and the fast charging behaviour are obtained.

The introduction of full electric vehicles where the motor and the power electronic converter are fed by a battery (or a fuel cell) will gain importance but a lot of engineers and scientists share the opinion that the use of an internal combustion engine will not disappear that fast. When considering internal combustion engines, improvements concerning efficiency and a reduction of the emission of exhaust gases are expected. Not only conventional internal combustion engine cars but especially hybrid electric vehicles have a future.

## Test Block

### Task 1. Match the words with close meaning:

- |    |              |    |             |
|----|--------------|----|-------------|
| 1. | challenge    | a. | number      |
| 2. | sufficiently | b. | variant     |
| 3. | amount       | c. | environment |
| 4. | due to       | d. | cut         |
| 5. | option       | e. | problem     |
| 6. | ambient      | f. | receive     |
| 7. | obtain       | g. | enough      |
| 8. | reduction    | h. | because of  |

### Task 2. Match the words with their definitions:

- |    |               |    |   |
|----|---------------|----|---|
| 1. | mandatory     | a. | rapid increase in the number or amount of something         |
| 2. | decent        | b. | cause someone to lose enthusiasm                            |
| 3. | weight        | c. | the way in which someone or something works or functions    |
| 4. | proliferation | d. | required by a law or rule                                   |
| 5. | discourage    | e. | something done by hard work                                 |
| 6. | effort        | f. | being moral and good  |
| 7. | behaviour     | g. | the maximum distance a vehicle can travel without refueling |
| 8. | range         | h. | a body's mass   |

### Task 3. Match the parts of the sentences:

- |    |  |    |  |
|----|--|----|--|
| 1. | Batteries must be able to store a sufficient amount of energy  | a. | is a self-heating lithium-ion battery.                 |
| 2. | A decent electrical grid infrastructure implies                | b. | but especially hybrid electric vehicles have a future. |
| 3. | Reaching a large range and realising a fast charging behaviour | c. | and the weight must be acceptable.                     |

- |    |   |    |   |
|----|---|----|---|
| 4. | One option of the all-<br>climate battery                   | d. | a proliferation of charging<br>stations.              |
| 5. | Not only conventional<br>internal combustion<br>engine cars | e. | is especially a challenge in<br>case of cold weather. |

**Task 4. Match questions with answers:**

- |    |  |
|----|--|
| 1. | How many battery technologies exist?   |
| 2. | What discourages the car drivers to use electric<br>vehicles?  |
| 3. | How do low temperatures effect electric vehicle<br>operation?  |
| 4. | What opinion do a lot of engineers and scientists share<br>about the future of the internal combustion engine? |
| 5. | How will the internal combustion engine be improved?   |
| a. | Improvements concerning efficiency and a reduction of<br>the emission of exhaust gases are expected.           |
| b. | The use of an internal combustion engine will not<br>disappear that fast.                                      |
| c. | A large number of different battery technologies exist.  |
| d. | Due to the low temperatures, the range decreases and the<br>required charging time increases.                  |
| e. | The fear that the battery will be discharged before<br>reaching the destination.                               |

## UNIT 8

### HYBRID VEHICLES

#### Word list:

1. hybrid	гібридний	гибридный
2. be intended	призначатися	предназначаться
3. petroleum fuel	нафтове паливо	нефтяное топливо
4. energy density	питома енергоємність	удельная энергоемкость
5. account for	забезпечувати	обеспечивать
6. primary energy source	первинний енергоносіє	первичный энергоноситель
7. guarantee	гарантувати	гарантировать
8. perhaps	можливо	возможно
9. replace	замінювати	заменять
10. secondary	вторинний	вторичный
11. accelerate	розганяти	разгонять
12. allow	дозволяти	позволять
13. recuperate	відновлювати	восстанавливать
14. brake	гальмо	тормоз
15. indeed	безсумнівно	несомненно
16. bidirectional	двоспрямований	двунаправленный
17. since	оскільки	так как
18. operate	функціонувати, працювати	функционировать, работать

#### Read and translate the text:

### HYBRID VEHICLES

Hybrid vehicles are intended to combine the advantages of vehicles having a conventional internal combustion engine and the advantages of electric vehicles. Vehicles having a conventional internal combustion engine have a large range since petroleum fuels have a high energy density. Electric vehicles have the advantage to account for no/less pollution while driving. Electric vehicles also have a higher energy efficiency than vehicles having an internal combustion engine.

Hybrid vehicles have more than one energy source. They have an internal combustion engine allowing the use of gasoline or diesel. Diesel or gasoline (or another fossil based fuel) is considered to be the primary energy source guaranteeing the large range of the vehicle. In the future, perhaps it will be possible to replace the diesel or gasoline by hydrogen. The primary energy source is mainly the steady state power source.

Hybrid vehicles also have an electrical motor which is generally battery fed. The battery is considered to be the secondary energy source. The secondary energy source is the dynamic power source (e.g. used while accelerating the vehicle). Batteries also allow to recuperate the brake energy. A battery is indeed a bidirectional energy source since a battery can be discharged and charged (while charging the battery, the electrical traction motor/machine operates as a generator).

### **Test block**

#### **Task 1. Match the words with close meaning:**

- |    |            |    |          |
|----|------------|----|----------|
| 1. | hybrid     | a. | minor    |
| 2. | guarantee  | b. | speed up |
| 3. | perhaps    | c. | restore  |
| 4. | secondary  | d. | because  |
| 5. | accelerate | e. | mixed    |
| 6. | recuperate | f. | work     |
| 7. | since      | g. | secure   |
| 8. | operate    | h. | possibly |

#### **Task 2. Fill in the gaps with the suitable words:**

- a. secondary
- b. allow
- c. brakes
- d. hybrid
- e. indeed
- f. replace

1. \_\_\_\_\_ vehicles have more than one energy source.
2. The new equipment is intended to \_\_\_\_\_ the old one.

3. Hybrid vehicles \_\_\_\_\_ the use of gasoline or diesel.
4. In hybrid vehicles the battery is considered to be the \_\_\_\_\_ energy source.
5. He got into the crash because of the problem with the \_\_\_\_\_ .
6. Diesel or gasoline \_\_\_\_\_ guarantee the large range of the vehicle.

**Task 3. Match the halves of the sentences:**

- |    |   |    |   |
|----|---|----|---|
| 1. | Hybrid vehicles combine the advantages of vehicles                  | a. | allowing the use of gasoline or diesel.                     |
| 2. | Vehicles with an internal combustion engine have a large range      | b. | do not pollute while driving.                               |
| 3. | Electric vehicles almost  | c. | by hydrogen.  |
| 4. | Hybrid vehicles have an internal combustion engine                  | d. | with the internal combustion engine and the electric motor. |
| 5. | In the future it will be possible to replace the diesel or gasoline | e. | since a battery can be discharged and charged.              |
| 6. | A battery is a bidirectional energy source                          | f. | since petroleum fuels have a high energy density.           |

**Task 4. Match questions with answers:**

1. Which vehicles have a higher energy efficiency, electric or with an internal combustion engine?
  2. How many energy sources do hybrid vehicles have?
  3. What is considered the primary energy source in hybrid vehicles?
  4. What is considered to be the secondary energy source?
  5. What energy source is used to accelerate the vehicle?
- a. The battery.
  - b. Electric vehicles.
  - c. More than one.
  - d. The secondary energy source.
  - e. Diesel or gasoline.

## UNIT 9

### HYBRID VEHICLES OPERATION MODES

#### Word list:

1.	operation mode	робочий режим	рабочий режим
2.	pure	чистий	чистый
3.	turn off	вимикати	выключать
4.	densely populated area	густонаселений район	густонаселенный район
5.	avoid	уникати	избегать
6.	noise pollution	шумове забруднення	шумовое загрязнение
7.	undesired	небажаний	нежелательный
8.	for instance	наприклад	например
9.	in case	у разі	в случае
10.	empty	порожній	пустой
11.	engine traction	тягове зусилля	тяговое усилие
12.	excess	надлишок	излишек
13.	approach	підхід	подход
14.	working point	робоча точка	рабочая точка
15.	provide	забезпечувати	обеспечивать
16.	efficiency	ефективність	эффективность
17.	low	низький	низкий
18.	regenerative braking	рекуперативне гальмування (з поверненням енергії)	рекуперативное торможение (с возвратом энергии)

#### Read and translate the text:

### HYBRID VEHICLES OPERATION MODES

When considering the drivetrain, a number of operation modes arise.

- Pure electric mode: The combustion engine is turned off and all the driving energy comes from the battery. This mode can e.g. be useful in a

densely populated area where exhaust gases need to be avoided and where also noise pollution is undesired.

- Pure engine mode: All the driving energy is coming from the combustion engine i.e. the batteries are not charged nor discharged. For instance, in case the battery is empty and still a long trip is needed, based on fossil fuels and the combustion engine the desired range is possible.
- Hybrid mode: The driving energy is coming from the combustion engine and from the batteries. This allows to provide a large power to the traction motor which can be useful during acceleration of the vehicle.
- Engine traction and battery charging: The engine-generator drives the vehicle and the excess of power is used to charge the batteries. This approach allows the combustion engine to operate at its optimal working point (providing a maximum efficiency) when the mechanical power required by the vehicle is lower than the power of the combustion engine.
- Regenerative braking mode: The traction motor/machine is operating as a generator and the brake energy is stored in the batteries (the combustion engine is not used).
- Battery charging mode: The car is not driven (no power is sent to the traction motor) but the engine-generator charges the batteries.
- Hybrid battery charging mode: The traction motor/machine operates as a generator, together with the engine-generator they charge the batteries.

## Test Block

### Task 1. Match the parts of the word-combinations:

- |    |              |    |           |
|----|--------------|----|-----------|
| 1. | operation    | a. | instance  |
| 2. | turn         | b. | case      |
| 3. | noise        | c. | point     |
| 4. | for          | d. | pollution |
| 5. | in           | e. | braking   |
| 6. | engine       | f. | mode      |
| 7. | working      | g. | traction  |
| 8. | regenerative | h. | off       |

**Task 2. Match the words with their definitions:**

- |    |            |    |  |
|----|------------|----|--|
| 1. | pure       | a. | give someone something that they need        |
| 2. | avoid      | b. | having nothing inside                        |
| 3. | empty      | c. | the good use of time and energy              |
| 4. | excess     | d. | not mixed with anything else                 |
| 5. | approach   | e. | keep away from                               |
| 6. | provide    | f. | not high or tall                             |
| 7. | efficiency | g. | a way of dealing with a situation or problem |
| 8. | low        | h. | more than necessary                          |

**Task 3. Match the hybrid vehicle operation modes with their description:**

1. Pure electric mode
  2. Pure engine mode
  3. Hybrid mode
  4. Engine traction and battery charging
  5. Regenerative braking mode
  6. Battery charging mode
  7. Hybrid battery charging mode
- 
- a. The driving energy is coming from the combustion engine and from the batteries.
  - b. The traction motor operates as a generator, together with the engine-generator they charge the batteries.
  - c. The traction motor is operating as a generator and the brake energy is stored in the batteries.
  - d. The combustion engine is turned off and all the driving energy comes from the battery.
  - e. The car is not driven but the engine-generator charges the batteries.
  - f. All the driving energy is coming from the combustion engine.
  - g. The engine-generator drives the vehicle and the excess of power is used to charge the batteries.

**Task 4. Decide if the following statements are true or false:**

1. Pure engine mode can be useful in a densely populated area. T/F
2. Pure electric mode is based on fossil fuels. T/F
3. Hybrid mode can be useful during acceleration of the vehicle. T/F
4. Using engine traction and battery charging allows the combustion engine to operate at its optimal working point. T/F
5. The batteries are charged with the engine-generator during the battery charging mode. T/F

## UNIT 10

### FUEL CELL CARS

#### Word list:

1.	fuel cell	паливний елемент	топливный элемент
2.	equip	обладнати	оборудовать
3.	storage tank	паливний бак	топливный бак
4.	fuel cell stack	батарея паливних елементів	батарея топливных элементов
5.	DC (direct current)	постійний струм	постоянный ток
6.	voltage	напруга	напряжение
7.	adjust	приспосовувати	приспосабливать
8.	date from	починатися	вести начало
9.	previous	попередній	предыдущий
10.	power density	щільність енергії	плотность энергии
11.	growth	зріст	рост
12.	common	звичайний	обычный
13.	available	наявний	имеющийся
14.	energy carrier	енергоносій	энергоноситель
15.	steam reforming process	паровий реформінг	паровой реформинг
16.	split	розпадатися	распадаться
17.	oxygen	кисень	кислород
18.	majority	більшість	большинство
19.	vapor	пара	пар

## Read and translate the text:

### FUEL CELL CARS

Hydrogen can be used to feed a hydrogen internal combustion engine but the use of hydrogen in combination with a fuel cell and an electrical motor is also a well known technology.

The car can be equipped with a hydrogen storage tank allowing to feed the fuel cell stack. Just like a battery, the fuel cell stack is a DC voltage source. Using power electronics, the speed of the electrical motor and the speed of the car can be adjusted to the needs of the driver.

The use of fuel cells dates from the sixties of the previous century. Although fuel cells were considered to be a promising technology by a lot of people, during a long time the use of fuel cells was not really practical. Fuel cells were too expensive and the power density of a fuel cell stack was too low. Due to more recent technological improvements, probably a real future arises for the use of fuel cells (also when considering road vehicles).

Prototypes of fuel cell cars are not new at all, but today there also exist commercial vehicles based on fuel cells (e.g. Hyundai, Toyota, Honda). Although the sales figures are still very limited, an important growth is expected.

Today there are the following ways of hydrogen production.

Hydrogen is very common in molecules like water  $H_2O$  or  $CH_4$  but hydrogen as a gas (i.e.  $H_2$ ) is almost not available on Earth. Hydrogen as  $H_2$  is a promising energy carrier but it is a secondary source of energy since it is almost not available on Earth. Based on e.g.  $CH_4$  or  $H_2O$  it is possible to produce  $H_2$  but this production requires energy. Based on methane  $CH_4$ , a steam reforming process allows to produce hydrogen  $H_2$ . By using electrolysis, water  $H_2O$  can be split into hydrogen  $H_2$  and oxygen  $O_2$ .

Today, the majority of the hydrogen production is based on the steam reforming process. At high temperatures (700 °C to 1100 °C), steam (water  $H_2O$  vapor) reacts with methane to produce hydrogen.

Approximately 5% of the hydrogen production is based on electrolysis. In its most basic form, electrolysis is used to split up water  $H_2O$  into hydrogen  $H_2$  and oxygen  $O_2$ .

## Test Block

### Task 1. Match the parts of word-combinations:

- |    |         |    |                   |
|----|---------|----|-------------------|
| 1. | fuel    | a. | from              |
| 2. | storage | b. | density           |
| 3. | direct  | c. | carrier           |
| 4. | date    | d. | current           |
| 5. | power   | e. | reforming process |
| 6. | energy  | f. | cell              |
| 7. | steam   | g. | tank              |

### Task 2. Fill in the gaps with appropriate words:

- equip
- adjust
- previous
- voltage
- oxygen
- vapor
- available
- growth

- The standard \_\_\_\_\_ in this country is 220 volts.
- We must \_\_\_\_\_ our policies to the changes.
- The sponsors' money was used to \_\_\_\_\_ our laboratories with modern apparatus.
- The furniture was left by the \_\_\_\_\_ owners of the house.
- The economic \_\_\_\_\_ was slowed down by the unstable political situation.
- The new data is \_\_\_\_\_ on our site.
- We cannot exist without \_\_\_\_\_ .
- Water \_\_\_\_\_ condensed and fell on Earth, and rivers appeared.

### Task 3. Match the questions and answers:

1. When did fuel cells appear?
  2. Why were not fuel cells considered practical for a long time?
  3. Are the sales figures of fuel cell cars high?
  4. What are the main processes of hydrogen production?
  5. How is the majority of the hydrogen produced?
  6. How much hydrogen is produced based on electrolysis?
- a. A steam reforming process and electrolysis.
  - b. They are still very limited, though an important growth is expected.
  - c. Due to a steam reforming process.
  - d. The use of fuel cells dates from the sixties of the previous century.
  - e. Approximately 5%.
  - f. They were too expensive.

### Task 4. Match the parts of the sentences:

- |   |  |
|---|--|
| 1. The car can be equipped with a hydrogen storage tank | a. but it is a secondary source of energy since it is almost not available on Earth. |
| 2. Hydrogen as $H_2$ is a promising energy carrier      | b. to produce hydrogen.  |
| 3. By using electrolysis,                               | c. allowing to feed the fuel cell stack.   |
| 4. At high temperatures, steam reacts with methane      | d. to split up water into hydrogen and oxygen.                                       |
| 5. In its most basic form, electrolysis is used         | e. water $H_2O$ can be split into hydrogen $H_2$ and oxygen $O_2$ .                  |

# UNIT 11

## ELECTRICAL SYSTEM OF THE CAR

### Word list:

1.	starter	стартер	стартер
2.	alternator	генератор змінного струму	генератор переменного тока
3.	ignition	запалювання	зажигание
4.	combustion	процес горіння	процесс горения
5.	supply	постачати	поставлять
6.	rotate	обертати	вращать
7.	flywheel	маховик	маховик
8.	alternating current (AC)	змінний струм	переменный ток
9.	recharge	перезаряджати	перезаряжать
10.	defroster	склообігрівач	стеклообогреватель
11.	wipers	склоочисник	стеклоочиститель
12.	accessories	обслуговувальні механізми	обслуживаемые механизмы
13.	faulty	несправний	неисправный
14.	erratically	з перебоями	с перебоями
15.	wires	дроти	провода
16.	connector	з'єднувач	соединитель
17.	fuse	запобіжник	предохранитель
18.	cable	кабель	кабель
19.	insulation	ізоляція	изоляция
20.	be in charge of	відповідати за	отвечать за
21.	glove compartment	бардачок	перчаточный ящик, бардачок
22.	continuity tester	тестер цілісності ланцюгів	тестер целостности цепей

## **Read and translate the text:**

### **ELECTRICAL SYSTEM OF THE CAR**

Electrical system of the car consists of the battery, starter and alternator.

**Battery.** Until your vehicle starts, your battery is providing the car's entire electrical current. This includes the current to the ignition and fuel systems, which are responsible for creating the combustion necessary for your engine to function.

**Starter.** While your battery supplies the power to start your vehicle, the starter is really what gets the engine going. The battery supplies a small amount of power to the starter motor. The starter then rotates the flywheel, which turns the crankshaft and begins the movement of the engine's pistons.

**Alternator.** The alternator gets its name from its primary function, which is to generate alternating current (AC). It recharges the battery and converts mechanical energy into electricity, which powers everything in the car – your lights, defroster, wipers and accessories.

When your engine is running, the alternator keeps the battery charged and the electrical system going. Your car can start with a faulty alternator, but it won't be able to run for an extended period of time. If the alternator requires replacement, your vehicle's electrical system will perform erratically, its battery will discharge, and eventually your engine will lose power.

**Wires, connectors and fuses.** All the electrical components of your car are connected by a series of cables. They're located throughout the car all the way to the trunk and are covered with insulation. Wires vary in diameter and are colour coded according to their voltage. Connectors make cars easy to service because they allow a mechanic to reach in and remove the faulty wires.

Fuses are in charge of keeping wires at a stable temperature. Your car likely has two fuse panels: one in the glove compartment and the other in the engine compartment. You can use a continuity tester to find out if the fuse is blown or simply pull it out and take a look.

## Test Block

**Task 1. Match the parts to make the words and word-combinations:**

- |    |              |    |             |
|----|--------------|----|-------------|
| 1. | fly-         | a. | froster     |
| 2. | alternating  | b. | of          |
| 3. | re-          | c. | compartment |
| 4. | de-          | d. | charge      |
| 5. | be in charge | e. | tester      |
| 6. | glove        | f. | wheel       |
| 7. | continuity   | g. | current     |

**Task 2. Match the words with their definitions:**

- |    |             |    |  |
|----|-------------|----|--|
| 1. | ignition    | a. | a flexible metallic conductor  |
| 2. | rotate      | b. | having defects   |
| 3. | wipers      | c. | a material that is used to stop heat, electricity, or sound from going into or out               |
| 4. | wires       | d. | the process of starting the combustion of fuel in the cylinders of an internal combustion engine |
| 5. | faulty      | e. | a safety device  |
| 6. | fuse        | f. | move in a circle round a centre  |
| 7. | accessories | g. | a device on an automobile for wiping windows   |
| 8. | insulation  | h. | things which can be added to something else to make it more useful                               |

**Task 3. Sort out the following characteristics by the components of the car electrical system:**

1. Battery
2. Starter
3. Alternator
4. Wires
5. Connectors
6. Fuses

- a. They make cars easy to service because they allow a mechanic to reach in and remove the faulty wires.
- b. They vary in diameter and are colour coded according to their voltage.
- c. It provides the car's entire electrical current.
- d. They are in charge of keeping wires at a stable temperature.
- e. It rotates the flywheel, which turns the crankshaft and begins the movement of the engine's pistons.
- f. It recharges the battery and converts mechanical energy into electricity.

**Task 4. Decide if the following statements are true or false:**

1. The ignition and fuel systems are responsible for creating the combustion necessary for your engine to function. T/F
2. The alternator is really what gets the engine going. T/F
3. Electricity powers everything in the car – your lights, defroster, wipers and accessories. T/F
4. When your engine is running, the alternator keeps the battery charged and the electrical system going. T/F
5. Your car likely has three fuse panels. T/F

## UNIT 12

### INTELLIGENT TRANSPORT SYSTEMS

#### Word list:

1.	intelligent	розумний	умный
2.	integrate	об'єднувати	объединять
3.	ICT (Information and Communication Technologies)	інформаційно- комунікаційні технології	информационно- коммуникационные технологии
4.	goal	мета	цель
5.	energy consumption	витрата енергії	расход энергии
6.	deal with	мати справу з	иметь дело с
7.	congestion	затор	затор
8.	lane	смуга дороги	полоса дороги
9.	solve a problem	вирішувати проблему	решать проблему
10.	tremendous	величезний	огромный
11.	reduce	зменшувати	уменьшать
12.	appropriate	відповідний	подходящий
13.	route	маршрут	маршрут
14.	concerning	що стосується	касающийся
15.	improve	поліпшувати	улучшать
16.	airbag	повітряна подушка безпеки	воздушная подушка безопасности
17.	measure, measurement	вимірювати, вимірювання, вимір	измерять, измерение
18.	protect	захищати	защищать
19.	anti-lock braking system	антиблокувальна гальмівна система	антиблокировочная тормозная система
20.	prevent	запобігати	предотвращать
21.	lock up	блокувати	блокировать
22.	emergency braking	аварійне гальмування	аварийное торможение

23.	stopping distance	шлях гальмування	путь торможения
24.	property	властивість	свойство
25.	steering	рульове керування	рулевое управление

**Read and translate the text:**

**INTELLIGENT TRANSPORT SYSTEMS**

By integrating electronic and ICT technology in cars, trains, trams, aircrafts or ships, a number of goals can be achieved. Engineers try to make the traffic on the road safer, reduce traffic jams, reduce the energy consumption while driving, combine the use of cars and trucks with the use of trains, trams, ships, aircrafts.

When dealing with ‘Intelligent Transport Systems’, two major goals arise. First, dealing with the increasing congestion of the roads which is a major problem in a lot of industrialised countries. Decent road infrastructure, including a sufficient number of roads with a sufficient number of lanes, is needed but will not be able to solve all problems. The congestion of the roads, including traffic jams, accounts for a tremendous loss of time causing a severe economic loss. Improving the road safety for all road users is a second major goal. To reach these goals a wide range of combined approaches are needed.

There exist a number of ways to reduce the congestion of the roads. By supplying correct and real-time traffic information to the (potential) drivers, they are able to choose the most appropriate route to the destination. Alternatively, the potential driver can be informed about alternative choices like using public transport. The traffic information needs to include correct information concerning the infrastructure works on the roads (including repair and maintenance works).

In order to improve the safety of all vehicles on the road, several approaches can be combined. A modern car already has a lot of mechatronic devices which improve the safety of the car.

The modern airbag system contains an accelerometer. In case of a car accident, a large (negative) acceleration will be measured. This measurement data is used to conclude an accident happens and the airbag will be opened to protect the car driver and the passengers.

Anti-lock braking system (ABS) operates by preventing the wheels of the car from locking up while braking (e.g. during an emergency braking). Achieving a smaller stopping distance (although not always realistic) is a good property but it is especially important to improve the steering control of the car.

### Test Block

#### Task 1. Match the parts to make words and word-combinations:

- |    |           |    |                |
|----|-----------|----|----------------|
| 1. | energy    | a. | braking system |
| 2. | deal      | b. | up             |
| 3. | solve     | c. | braking        |
| 4. | anti-lock | d. | distance       |
| 5. | lock      | e. | consumption    |
| 6. | emergency | f. | bag            |
| 7. | air       | g. | with           |
| 8. | stopping  | h. | problem        |

#### Task 2. Match the words with their definitions:

- |    |             |    |  |
|----|-------------|----|--|
| 1. | intelligent | a. | bring together into a whole                  |
| 2. | integrate   | b. | a way to get from one place to another place |
| 3. | goal        | c. | a thing or things belonging to someone       |
| 4. | lane        | d. | road section for one line of traffic         |
| 5. | route       | e. | desired result                               |
| 6. | property    | f. | with high mental ability                     |

#### Task 3. Fill in the gaps with the suitable words:

- |    |             |
|----|-------------|
| a. | congestion  |
| b. | tremendous  |
| c. | reduce      |
| d. | appropriate |

- e. improved
- f. steering

1. Globalization presents \_\_\_\_\_ potential for economic growth.
2. The Internet has \_\_\_\_\_ communication greatly.
3. He was \_\_\_\_\_ with only one hand.
4. Road \_\_\_\_\_ is a major problem in a lot of industrialised countries.
5. This book is not \_\_\_\_\_ for children.
6. Electric vehicles \_\_\_\_\_ pollution.

**Task 4. Match the parts of the sentences:**

- |   |   |
|---|---|
| 1. The congestion of the roads  | a. they are able to choose the most appropriate route to the destination. |
| 2. There exist a number of ways   | b. by preventing the wheels of the car from locking up while braking.     |
| 3. By supplying correct and real-time traffic information to the drivers, | c. accounts for a tremendous loss of time causing a severe economic loss. |
| 4. Anti-lock braking system operates                                      | d. which improve the safety of the car.                                   |
| 5. A modern car already has a lot of mechatronic devices                  | e. to reduce the congestion of the roads.                                 |

**Task 5. Match questions and answers:**

1. What goals do engineers try to achieve using ICT in cars?
2. What are two major problems in industrialised countries?
3. How is the most appropriate route chosen?
4. How does anti-lock braking system operate?
5. What can improve the steering control of the car?

- a. By preventing the wheels of the car from locking up while braking.
- b. They make the traffic on the road safer, reduce traffic jams, reduce the energy consumption.
- c. By supplying correct and real-time traffic information to the drivers.
- d. Achieving a smaller stopping distance.
- e. Congestion and road safety.

## UNIT 13

### FUTURISTIC VEHICLES

#### Word list:

1.	self-driving car	безпілотний автомобіль	беспилотный автомобиль
2.	go mainstream	ставати популярним	становиться популярным
3.	automaker	автовиробник	автопроизводитель
4.	when it comes to	коли йдеться про	когда речь идет о
5.	autonomous	автономний	автономный
6.	ability	здатність	способность
7.	infancy	початкова стадія розвитку	начальная стадия развития
8.	gain momentum	зростати, поширюватися	набирать ход
9.	electric-propulsion system	електрична рухова установка	электрическая двигательная установка
10.	carbon emission	вуглецевімістки викиди	углеродосодержащие выбросы
11.	hyperloop	гіперпетля	гиперпетля
12.	affordable	доступний	доступный
13.	via	через	через
14.	passenger pod	капсула, відсік	капсула, отсек
15.	exceed	перевищувати	превышать
16.	be bound	повинен	должен
17.	reusable	багаторазовий	многооборотный
18.	accessible	доступний	доступный
19.	bring down	знижувати (ціну)	снижать (цену)
20.	significantly	значно	значительно

## Read and translate the text:

### FUTURISTIC VEHICLES

Transportation is undergoing one of the biggest transformations in history.

From self-driving cars to the Hyperloop, companies are investing in new ways for humans to get from point A to point B more efficiently.

Here's a look at some of the vehicles and transport systems that could dramatically change how we travel on Earth and, possibly, even to other planets.

*Electric cars* are already here and are helping make the world greener. They are going mainstream. Numerous major automakers already offer fully electric, long-range cars.

*Self-driving cars* could help save lives and time. They are quickly becoming a reality. Self-driving cars are expected to bring some big advantages, especially when it comes to safety. According to a study, if about 90% of cars on American roads were autonomous, the number of accidents would fall from 6 million a year to 1.3 million.

Besides safety, autonomous vehicles are also expected to help those who do not have the ability to drive – like elderly people – become more mobile.

*Flying cars* may still be in their infancy, but they are gaining momentum.

Terrafugia, a flying-car startup, is aiming to have its newest flying vehicle, called the TF-X in the coming years. The TF-X will take off, fly, and land autonomously.

Like electric cars, *electric planes* are also becoming a reality.

NASA and major aircraft makers are working to develop electric-propulsion systems. These electric planes would be more efficient, greatly help reduce carbon emissions, as well as decrease noise pollution.

*Hyperloop systems* could provide an affordable, efficient way to travel between major cities.

Traveling via passenger pods through tunnels at speeds exceeding 800 kmph is bound to make traveling faster, but it could also make traveling more efficient.

Because the Hyperloop is in a controlled environment and is completely autonomous, it would likely mean there would never be delays because of weather or because of an operator's error.

*Reusable rockets* could revolutionize space travel and help make human life interplanetary.

Reusable rockets are key to making space travel more accessible. This is because if a rocket can be used more than once, the cost of spaceflight can be brought down significantly.

### Test Block

#### Task 1. Match the parts of the words and word-combinations:

- |    |              |    |            |
|----|--------------|----|------------|
| 1. | self-driving | a. | momentum   |
| 2. | go           | b. | maker      |
| 3. | auto         | c. | emission   |
| 4. | gain         | d. | loop       |
| 5. | carbon       | e. | pod        |
| 6. | hyper        | f. | car        |
| 7. | passenger    | g. | down       |
| 8. | bring        | h. | mainstream |

#### Task 2. Match the words with their definitions:

- |    |            |    |   |
|----|------------|----|---|
| 1. | autonomous | a. | not expensive                               |
| 2. | ability    | b. | the period of early childhood               |
| 3. | infancy    | c. | travelling through a place to a destination |
| 4. | affordable | d. | having the freedom to control itself        |
| 5. | via        | e. | able to be used more than once              |
| 6. | exceed     | f. | talent and skills in some area              |
| 7. | reusable   | g. | able to be reached or easily got            |
| 8. | accessible | h. | be greater than                             |

### Task 3. Sort out characteristics according to the objects:

1. Electric cars
2. Self-driving car
3. Flying cars
4. Electric planes
5. Hyperloop system
6. Reusable rockets

a.	help make human life interplanetary
b.	take off, fly, and land autonomously
c.	help make the world greener
d.	travel via passenger pods through tunnels at high speeds
e.	help those who do not have the ability to drive to become more mobile
f.	reduce carbon emissions, decrease noise pollution

### Task 4. Match questions and answers:

1. What is the biggest advantage of self-driving cars?
  2. What is Terrafugia?
  3. Who produces electric planes?
  4. What can hyperloop systems provide?
  5. How can reusable rockets revolutionize space travel?
- 
- a. The cost of spaceflight can be brought down significantly.
  - b. NASA and major aircraft makers.
  - c. Safety.
  - d. Efficient way of travelling between major cities.
  - e. A flying-car start-up.

## UNIT 14 FLYING CARS

### Word list:

1.	deliver	доправляти	доставлять
2.	breakthrough	прорив	прорыв
3.	viable	життєздатний	жизнеспособный
4.	onboard	бортовий	бортовой
5.	handle	управлятися з	управляться с
6.	rare	рідкісний	редкий
7.	directional layering	спрямоване розбиття на рівні	направленное разбиение на уровни
8.	manage the traffic	керувати транспортом	управлять транспортом
9.	particular	окремий	отдельный
10.	altitude	висота	высота
11.	eliminate	усувати	устранять
12.	low-impact	щадний, з низьким рівнем впливу	щадящий, с низким уровнем воздействия
13.	runway	злітно-посадкова смуга	взлетно-посадочная полоса
14.	capability	здатність	способность
15.	silent	тихий	тихий
16.	put up with	мириться з	мириться с
17.	collision	зіткнення	столкновение
18.	avoidance	уникнення	избежание
19.	drop-out-of-the-sky	той, що падає з неба	падающий с неба

## Read and translate the text:

### FLYING CARS

The flying car era really began with flying drones. Soon flying drones will be widely used to deliver packages, pizzas, and groceries.

The following six key technological breakthroughs will be needed for the first generation of flying cars to become viable.

1. *Fully automated navigation systems.* The flying car industry will not be able to “get off the ground” without an onboard navigator that “handles the driving”. Yes, people will want the freedom of being able to do some creative maneuvering in certain situations, but that will only be allowed in rare instances.

2. *Directional layering of airspace.* With several hundred thousand vehicles flying over a city, there will be a need for an organized system for managing the traffic, and having all vehicles at a particular altitude traveling the same direction would eliminate many problems.

3. *Low-impact vertical take-off.* For use by the average person, flying cars cannot have a runway requirement because they need to take off and land vertically.

4. *Convenient fly-drive capability.* As humanity makes the transition from ground-based autos to flying cars there will be a need for both driving on the ground and flying in the air.

5. *Silent engines.* Very few cities will want to put up with the noise of several hundred thousand flying vehicles if they all sound like airplanes today.

6. *Specialized safety systems.* Safety technologies will include collision avoidance systems and drop-out-of-the-sky emergency airbags on the outside of vehicles.

## Test Block

### Task 1. Match the parts of the words and word-combinations:

- |                |                |
|----------------|----------------|
| 1. break       | a. layering    |
| 2. on          | b. the traffic |
| 3. directional | c. impact      |
| 4. manage      | d. through     |
| 5. low-        | e. with        |
| 6. run         | f. of-the-sky  |
| 7. put up      | g. board       |
| 8. drop-out    | h. way         |

### Task 2. Match the words with their definitions:

- |              |   |
|--------------|---|
| 1. deliver   | a. not making any sound                                 |
| 2. viable    | b. hitting each other                                   |
| 3. rare      | c. bring something to a certain address                 |
| 4. altitude  | d. the vertical elevation of an object above the ground |
| 5. silent    | e. able to live and grow                                |
| 6. collision | f. not found very often                                 |

### Task 3. Fill in the gaps with the suitable words:

- a. handle
- b. particular
- c. eliminate
- d. capability
- e. avoidance

1. Our engineers are trying to \_\_\_\_\_ all the defects of the trial model.
2. Flying cars is an area of his \_\_\_\_\_ interest.

3. We are working on collision \_\_\_\_\_ .
4. Does the company have the \_\_\_\_\_ to meet the market need?
5. You should \_\_\_\_\_ this substance with care.

**Task 4. Match the expected technological breakthroughs in the area of flying cars with their description:**

1. Fully automated navigation systems
  2. Directional layering of airspace.
  3. Low-impact vertical take-off
  4. Convenient fly-drive capability
  5. Silent engines
  6. Specialized safety systems
- 
- a. Operating without runway equipment
  - b. Reducing noise
  - c. Onboard navigator that handles the driving
  - d. Providing fly-drive equipment
  - e. Developing collision avoidance system and emergency airbags
  - f. Organized system for managing the traffic

**Task 5. Match the parts of the sentences:**

- |  |   |
|--|---|
| 1. The flying car era  | a. there will be a need for both driving on the ground and flying in the air. |
| 2. Having all vehicles at a particular altitude traveling the same direction | b. if they all sound like airplanes today.                                    |
| 3. As humanity makes the transition from ground-based autos to flying cars   | c. collision avoidance systems and drop-out-of-the-sky emergency airbags.     |

4. Very few cities will want to put up with the noise of several hundred thousand flying vehicles
  5. Safety technologies will include
- d. began with flying drones.
  - e. would eliminate many problems.

## UNIT 15

### FUTURE TRENDS IN TRANSPORTATION

#### Word list:

1.	be dependent upon	залежати	зависеть
2.	decline	спадати	пойти на убыль
3.	through the roof	хоч греблю гати	выше крыши
4.	downward	спадний	нисходящий
5.	trigger	запускати	запускать
6.	adoption	упровадження	внедрение
7.	vessel	судно	судно
8.	freight	вантаж	груз
9.	biofuel	біопаливо	биотопливо
10.	magnetic levitation	магнітна левітація	магнитная левитация
11.	rail	рейка	рельс
12.	friction	тертя	трение
13.	enable	давати змогу	давать возможность
14.	medium capacity	середньої місткості	средней вместимости
15.	track	колія	колея
16.	elevate	піднімати	возвышать
17.	grade	рівень землі	уровень земли
18.	suspend	підвішувати	подвешивать
19.	straddle	охоплювати з обох боків	охватывать с двух сторон
20.	guide way	напрямний паз	направляющий паз
21.	complexity	складність	сложность
22.	gradual	поступовий	постепенный
23.	decaying	занепад, руйнування	упадок, разрушение

24.	at full capacity	на повну потужність	на	полную мощность
25.	harmless	нешкідливий		безвредный
26.	beam	промінь		луч
27.	intersect	перетинатися		пересекаться
28.	capture approval	завоювати схвалення		завоевать одобрение
29.	fall by the wayside	опинитися на узбіччі		оказаться на обочине

### **Read and translate the text:**

## **FUTURE TRENDS IN TRANSPORTATION**

All countries are still heavily dependent upon oil as their main source for energy. However, oil resources are decreasing forcing populations to look for alternatives. Oil reserves are expected to reach their peak in the next few years and then decline, sending energy prices through the roof.

This downward trend in energy supplies is expected to trigger a transition in the way people transport themselves and the goods they need for day to day living. So, what is expected to happen? Populations are expected to move toward automated transport systems, that move very fast, are highly efficient, safe and reliable. The adoption of the vehicles and vessels will lead to automated highway systems and new modes of bigger and better public transit and freight transportation.

Hybrid cars are being developed, with some already on the roadways. Other alternatives to oil are biofuels, e.g. cooking oil.

Yet another developing trend is represented by fuel cells that have low environmental impact and are now in mass production.

Some alternatives to modern day transportation include the Maglev, which is short for magnetic levitation, which allows passenger vehicles to ride above the rail so to speak, increasing speed by eliminating friction. Maglev has no moving parts, which enables the vehicles to reach speeds of 600km per hour.

Monorails have found applications in airport transfer and medium capacity metros. A monorail is defined as a single rail serving as a track for passenger or freight vehicles. In most cases rail is elevated, but

monorails can also run at grade, below grade or in subway tunnels. Vehicles either are suspended from or straddle a narrow guide way.

Because of friction-free technologies and advances in material science, the average passenger vehicle will weigh less than 500 kg.

Because of automation, far fewer pieces, and greatly reduced complexity, the average manufacturing time for a vehicle will be less than one hour.

Once the flying car industry takes off there will be a gradual decaying of the existing highway system. Eventually highways will go away, starting around 2070.

We will have space elevators operating at full capacity, moving both people and supplies into space.

Several space stations will have been started as small working cities to build the next generation of space-based industries.

The automotive industry will make a near-complete transition to binary power as a principle source of vehicular power. Binary power is the concept where two harmless beams of energy will intersect at some point in space creating a source of power.

The world is in such a transition now that it is difficult to predict which future transportation trends will capture mass approval and which will fall by the wayside. Only time will tell. However, the world will have to act quickly to keep up with the changing needs of the world population which is only growing every minute.

## Test Block

### Task 1. Match the parts of the words and word-combinations:

- |    |              |    |                |
|----|--------------|----|----------------|
| 1. | be dependent | a. | fuel           |
| 2. | through      | b. | way            |
| 3. | magnetic     | c. | capacity       |
| 4. | bio          | d. | upon           |
| 5. | guide        | e. | approval       |
| 6. | at full      | f. | by the wayside |
| 7. | capture      | g. | the roof       |
| 8. | fall         | h. | levitation     |

## Task 2. Match the words with their definitions:

- |    |          |    |   |
|----|----------|----|---|
| 1. | trigger  | a. | a structure consisting of parallel lines of rails           |
| 2. | beam     | b. | initiate something  |
| 3. | freight  | c. | goods carried by a ship, train, truck, or airplane          |
| 4. | friction | d. | the action of one surface or object rubbing against another |
| 5. | track    | e. | a ray of light  |

## Task 3. Fill in the gaps with the suitable words:

- a. declined
- b. vessel
- c. biofuel
- d. suspend
- e. gradual
- f. harmless
- g. intersect

1. Today \_\_\_\_\_ costs much more than fossil fuels.
2. It was just a \_\_\_\_\_ joke.
3. This is a place where many roads \_\_\_\_\_ .
4. This \_\_\_\_\_ is designed for underwater exploration.
5. Car sales have \_\_\_\_\_ by a quarter this year.
6. There was a \_\_\_\_\_ change for the better in the car industry after some stagnation.
7. These monkeys can \_\_\_\_\_ from the branches by their tails.

**Task 4. Put the subtitles to the paragraphs in the order they appear in the text:**

- a. The automotive industry will make a transition to binary power as a principle source of vehicular power.
- b. Fuel cells have low environmental impact and are now in mass production.
- c. There will be a gradual decaying of the existing highway system.
- d. Oil resources are decreasing forcing population to look for alternatives.
- e. Monorails have found applications in airport transfer and medium capacity metros.
- f. Populations are expected to move toward automated transport system.
- g. The Maglev allows passenger vehicles to ride above the rail increasing speed by eliminating friction.
- h. Hybrid cars are being developed.
- i. Space stations will operate as small working cities.

- 1. d
- 2.
- 3.
- 4.
- 5.
- 6.
- 7.
- 8.
- 9.

**Task 5. Match questions and answers:**

- 1. How can automated transport be characterized?
- 2. What is one of the alternatives to oil?
- 3. What is the advantage of fuel cells?
- 4. Why can Maglev reach high speeds?
- 5. How is a monorail defined?
- 6. Why will highways eventually go away?

7. What is binary power?
- a. Biofuel.
  - b. It has no moving parts.
  - c. They have low environmental impact.
  - d. It moves very fast, is highly efficient, safe and reliable.
  - e. It is the concept where two harmless beams of energy will intersect at some point in space creating a source of power.
  - f. Because of the development of the flying car industry.
  - g. As a single rail serving as a track for passenger or freight vehicles.

## SUPPLEMENTARY READING

### THE STORIES BEHIND FAMOUS CAR LOGOS

Here's a look at the history of some of the world's most iconic car logos.

#### 1. Toyota.

In 1989, to mark the company's 50<sup>th</sup> anniversary, Toyota redesigned its logo, incorporating three overlapping ovals, with the inner two forming a letter T and a steering wheel, as well as representing how the customers' expectations [horizontal] and car manufacturer's ideal [vertical] are firmly interlocked to form the letter T, according to the company. The outermost oval represents the world embracing Toyota.

#### 2. Cadillac

The American luxury takes its name from French explorer Antoine de Cadillac, the founder of Detroit, and the company crest is based on the Cadillac family coat of arms. The symbols included three coloured bands (representing boldness, virtue and valor), a crown, a wreath, and several small ducks.

#### 3. Audi

Like many automobile manufacturers, Audi consolidated multiple companies into a single business during the 20<sup>th</sup> century. An early logo shows the four original company names (Audi, DKW, Horch and Wanderer) each within their own ring. The text disappeared, but the interlocking rings have remained.

#### 4. BMW

The blue and white are merely an ode to the Bavarian flag.

#### 5. Subaru

In Japanese, *Subaru* is the name of the star cluster in the Taurus constellation, one of the nearest star clusters visible to the naked eye. Officially, the first president of the company felt it was a beautiful Japanese word.

#### 6. Chevrolet

Accounts differ on what inspired Chevrolet and General Motors co-founder William Durant to create the car company's famous bowtie logo. Some say Durant had a dream stirred by a wallpaper

design from a French hotel; another version – it was modelled on the flag of Switzerland, in honour of the birthplace of his partner, Swiss race car driver Louis Chevrolet.

#### 7. Mercedes-Benz

The iconic three-pointed star established motorized domination in three places: the sea, air and land.

#### 8. Volvo

The ancient symbol for the Roman god Mars has long been associated with weapons and warfare, and is also the alchemist symbol for iron. The Swedish company, known for its safe, sturdy vehicles, adopted the iron badge when it began manufacturing cars in the 1920s.

#### 9. Ferrari

Italian race car driver Enzo Ferrari was asked to paint a prancing horse on his vehicles to honour pilot and World War I hero Francesco Barraca, who painted a similar horse on his plane.

#### 10. Peugeot

The lion emblem was first added to a car model in 1905, and has become increasingly stylized since then, with the more abstract lion first appearing in 1975.

#### 11. Infiniti

A luxury spinoff from Nissan, Infiniti debuted two models in 1989. The “infinity” concept in its logo with two central lines in the center of a badge, symbolizes a road leading into a vast unknown landscape.

#### 12. Alfa Romeo

Quite possibly the most mysterious car logo, the cross and man-eating snake can be traced to the Italian city of Milan and its former ruling family, the Viscontis. They fought in the First Crusades and defeated Saracens in battle. It is considered that the snake isn't eating the man, but that the man is instead coming out of the snake renewed.

#### 13. Lamborghini

Legend has it that as the company was being conceived, founder Ferruccio Lamborghini was on the ranch, where bullfighting bulls were bred. He was a noted bullfighting enthusiast, besides, his birthday also fell under the Taurus astrological sign.

## **AUTOMOBILE FUN FACTS**

### **1. Windshield wipers were invented by a woman named Mary Anderson**

In 1905, Mary Anderson invented windshield wipers to remove the hassle of driving in the rain or snow. Before windshield wipers were invented, drivers would clean off the windshield by hand.

### **2. The first electric vehicle was created in 1832**

Robert Anderson created the first electric-powered vehicle in 1832. Then in the 1990s, General Motors produced the EV1, known as the first mass-produced electric car. Today, many drivers are opting to purchase an electric car to reduce their carbon footprint.

### **3. The world's first automobile race was in 1895 with a winning speed of 24 kmph**

### **4. Brake Lights Were Invented In 1905**

Prior to the invention of brake lights, many drivers relied on hand signals to let others know where they were going. This was problematic at night time as the dark made it difficult to see hand signals. Now, brake lights are a requirement for vehicles as they are an important safety feature!

### **5. The inventor of cruise control, Ralph Teetor, was blind**

Ralph Teetor got into an accident when he was five years old that caused him to be blind. The accident never stopped his curiosity thought! He eventually set out to create a mechanism that could keep the vehicle speed constant in order to save fuel.

### **6. Prior to the invention of the steering wheel, drivers used a lever to steer the car**

Steering wheels were invented in Cleveland, Ohio, by a man named Alexander Winton. Back in 1896, Winton began a series of inventions relating to cars and is most known for his steering wheel.

### **7. The car radio was first introduced by Chevrolet**

In 1922, the first car radio was introduced by Chevrolet. The government wanted to ban it because it could be considered a distraction, but the ban didn't go through. By 1963, most vehicles had radios in them.

### **8. The best-selling car of all time is the Toyota Corolla**

Toyota has sold more than 43 million Toyota Corollas since 1966! This model is extremely popular because it is widely available

all over the world, it continues to get updated and improved each year, it has good gas mileage, and it's well-known for being a reliable vehicle.

**9. Toyota is the largest car manufacturer in the world**

Toyota makes approximately 13,000 cars every day! No wonder Toyotas are one of the most popular cars on the road today.

**10. Ferrari only manufactures a maximum of 14 cars a Day**

The Ferrari manufacturers only produce 14 cars a day. That is a very large difference from Toyota's 13,000 vehicles a day! The limited number of vehicles produced makes them more exclusive and valuable.

**11. The largest car collection world record is 7,000+ cars**

The 29th Sultan of Brunei owns over 7,000 cars of all different makes and models. He owns extremely rare, one-of-a-kind cars as well as more popular ones.

**12. 95% of a car's lifetime is spent parked**

Your car spends only 5% of its lifetime on the road. The rest of its lifetime will be spent parked overnight or while not in use. This is why it is so important to park your car in a safe spot like a private garage or a driveway.

**13. The average American spends over 38 hours in traffic every year**

**14. Cars on the road are getting older over time**

The average age of cars on the road in 2010 was 10.6 years, and in 2019 it was 11.8. This number is expected to continue growing as newer vehicles are built with more complex technology, allowing them to have a longer lifespan.

**15. The most common car colour is white and the least popular car colour is purple**

White, black, and grey are the most popular car colours. Brighter, less-common colours like purple, orange, and yellow are not as easy to find.

# ARTIFICIAL INTELLIGENCE IN CARS

1) AI (Artificial intelligence) is being implemented at rapid speed in a variety of sectors, but the way in which it is being used in the automotive industry is a hot-button issue right now.

Though many believe personal, autonomous vehicles are the future, there are multiple ways in which AI and machine learning are being implemented in how vehicles are built and how they operate on the road.

I would like to present the overview of companies which are at the forefront of autonomous vehicle technology.

## **NUTONOMY: navigating complex traffic situations**

Location: Boston, Massachusetts

NuTonomy is creating autonomous technology for completely driverless vehicles. It allows for flexible and human-like vehicle handling (without the error). The software enables vehicles to navigate even the most complex traffic situations.

## **AUTOX: self-driving grocery delivery**

Location: San Jose, California

The company's vehicles combine AI software, sensors, real-time cameras and thousands of test miles, both virtual and real, to ensure safe decisions on the road. Currently with a focus on grocery delivery, users can pick items through their app and have them delivered along with the ability to browse their vehicle-based mobile store upon delivery.

## **DRIVE.AI: transporting passengers on fixed routes**

Location: Mountain View, California

Drive.ai is utilizing artificial intelligence to change current transportation systems with self-driving services. The vehicles are not only autonomous, they also communicate with drivers and pedestrians within the vicinity, such as displaying a sign to pedestrians indicating it will wait for them to cross.

## **OPTIMUS RIDE: sustainable transportation**

**Location:** Boston, Massachusetts

Optimus Ride is a self-driving vehicle company that creates autonomous cars for geo-fenced locations. The company's smart, electric

vehicles enable the implementation of more efficient and sustainable cities, freeing up parking, limiting the amount of cars on the road and decreasing environmental impact.

### **WAYMO: 360-degree perception technology**

Location: Mountain View, California

Beginning as Google's exploration of self-driving vehicles, Waymo is now its own company creating driverless vehicles that can safely deliver people from points A to B. With over eight million autonomous miles driven to date, Waymo's 360-degree perception technology detects pedestrians, other vehicles, cyclists, road work and other obstacles from up to 300 yards away.

### **ZOOX: robotic ridesharing**

Location: Foster City, California

While some companies are outfitting existing vehicles with self-driving capabilities, Zoox is creating their own autonomous vehicles from scratch.

The cars are being produced to be a robotic rideshare vehicle. Similar to current transportation services like Uber or Lyft, a user would summon a Zoox vehicle for a ride through an app on their smartphone.

2) There are many different types of AI-powered advanced driver-assistance system (ADAS) like automatic braking, driver drowsiness detection, lane departure warning and other safety features.

Here's how a few companies are using artificial intelligence in driver-assisted technologies to make the roads safer.

### **CARVI: altering bad driving habits**

Location: San Francisco, California

CarVi makes an ADAS that can be used for personal vehicles, fleets, ride-sharing or auto insurance companies.

CarVi uses AI to provide driving analysis and real-time alerts to warn drivers of possible dangers like lane departure, forward collisions and driving conditions. CarVi also uses a scoring system to rate driving skills and help drivers alter bad behaviors and habits.

## **NAUTO: keeping commercial fleets safe**

Location: Palo Alto, California

Nauto creates AI sensor technology for commercial fleets. Nauto's intelligent driver system reduces distracted driving that leads to collisions by assessing driver behavior. The system uses data to keep drivers attentive enough to avoid collisions and traffic violations.

# **MODERN CHALLENGES IN AUTOMOBILE ELECTRONICS**

Current ecological, social, and technological trends are encouraging innovative manufacturers to offer consumers much more than a metal box on four wheels. Now it's a smartphone on wheels with the following trends of development.

## **1. Autonomous Vehicles (AV)**

Autonomous vehicles or self-driving vehicles aim to minimize the need for human drivers, reduce downtime, and make public transportation relatively safer. For example, by reducing accidents caused by driver fatigue or negligence. AVs are equipped with advanced recognition technologies, such as AI-enhanced computer vision to identify obstacles along the route.

## **2. Connectivity**

Nowadays, vehicles come with a tamper-proof digital identity that differentiates them from other vehicles in the network. This enables easy tracking of vehicular data for various use cases such as insurance, driver safety, predictive maintenance, and fleet management.

## **3. Electrification**

The depleting fossil fuel reserves and the harm to the environment caused by their use, call for promoting the use of electric vehicles (EVs). For greater adoption, EVs need to address issues such as high price, poor battery, and inadequate charging infrastructure.

## **4. Shared Mobility**

Shared Mobility enables mobility-as-a-service and discourages unused vehicles. Such solutions meet the requirements of a city without adding new vehicles.

## **5. Artificial Intelligence (AI)**

Artificial intelligence technologies guide self-driving cars, manage fleets, assist drivers to improve safety and improve services such as vehicle inspection or insurance.

## **6. Big Data & Data Analytics**

Data gathered from vehicles enables predictive maintenance, informs managers about their fleets, and alerts concerned authorities in case of accidents.

## 7. Human-Machine Interface

Self-driving cars will fundamentally change how drivers interact with vehicles. Human-machine interfaces (HMI) use voice-based or haptic feedback to operate vehicles. Another form of HMI includes smart virtual assistants who help drivers and riders interact with the vehicles and other service providers.

## 8. Blockchain

Blockchain finds multiple applications in the automotive industry. These include sharing vehicle data over a secure network for connectivity and shared mobility solutions such as ride-hailing, urban transportation, and deliveries.

## 9. Additive Manufacturing

3D printing helps the automotive industry in three primary ways. Firstly, it enables rapid prototyping with 3D printed models that accelerate the design and testing phases of production. Secondly, it allows manufacturers to print spare parts to match their requirements. Lastly, additive manufacturing of composite materials leads to automotive parts that are lighter, stronger, and more durable.

## 10. Internet of Things (IoT)

In the automotive industry, IoT enables secure communication between vehicles as well as vehicles and infrastructure components. The technology improves road safety, solves traffic congestion, and reduces pollution and energy expenditure. The technology also automates payments for fuel and tolls.

## **ECOLOGY AND TRANSPORT INFRASTRUCTURE**

The environmental impact of transport is significant because transport is a major user of energy, and burns most of the world's petroleum. This creates air pollution, and is a significant contributor to global warming through emission of carbon dioxide. Within the transport sector, road transport is the largest contributor to global warming.

Energy use and emissions vary largely between modes, causing environmentalists to call for a transition from air and road to rail and human-powered transport, and increase transport electrification and energy efficiency.

The transportation sector is a major source of greenhouse gas emissions (GHGs) in the United States. An estimated 30 percent of national GHGs are directly attributable to transportation – and in some regions, the proportion is even higher.

Other environmental impacts of transport systems include traffic congestion and automobile-oriented urban sprawl, which can consume natural habitat and agricultural lands. By reducing transportation emissions globally, it is predicted that there will be significant positive effects on Earth's air quality, acid rain, smog and climate change.

The health impact of transport emissions is also of concern. Recent studies of the effect of traffic emissions on pregnancy outcomes have linked exposure to emissions to adverse effects on pregnancy duration and possibly also intrauterine growth.

Such impacts as noise pollution and carbon monoxide emissions create direct and harmful effects on the environment. The synergetic consequences of transport activities take into account of the varied effects of direct and indirect impacts on an ecosystem. Climate change is the sum total impact of several natural and human-made factors. 15 % of global CO<sub>2</sub> emissions are attributed to the transport sector.

The following changes are recommended to mitigate the impact of transport on ecology.

Develop a traffic management plan for site access roads and for use of main public roads.

Develop and implement measures to control off-highway vehicle traffic off of newly constructed access roads.

Instruct and require all personnel and contractors to adhere to speed limits to ensure safe and efficient traffic flow.

Encourage project employees to carpool to work sites.

Limit construction vehicle traffic on public roadways to off-peak commuting times to minimize impacts on local commuters.

Restore roads to equal or better condition than before project construction after the heavy construction period is complete.

Lastly, controlling dust along unsurfaced roads – especially near residences and farm fields – may help prevent mixture of plants that can lead to disputes over patents.

People can contribute to mitigation of transportation impact on the environment doing the following things.

Walking, cycling trips, short or non-commute trips can be an alternate mode of transportation when traveling short or even long distances.

A multi-modal trip involving walking, a bus ride, and bicycling may be counted solely as a transit trip.

Economic evaluations of transportation investments often ignore the true impacts of increased vehicular traffic – incremental parking, traffic accidents, and consumer costs – and the real benefits of alternative modes of transport.

## THE LATEST TRENDS IN AUTOMOTIVE INDUSTRY

The mobility of the future is abbreviated as “easycy” – electrified, autonomous, shared, connected, and “yearly” updated. This means the following.

- It will emit less exhaust fumes and noise into its environment because it is electric.
- It will take up less personal time and space because it moves autonomously.
- It will be more accessible because users will not need a driving licence to use it.
- It will be more affordable because it will no longer have to be bought outright but can instead be paid for in small amounts per use.

Let’s consider all these aspects in particular.

*Electrified* means the transition to emissions-free mobility that is becoming a global requirement. Electricity used to charge vehicles will increasingly come from renewable sources to ensure carbon dioxide-neutral mobility.

*Autonomous.* The rapid progress made in areas such as artificial intelligence, machine learning and deep neural networks make it possible to achieve what until recently seemed utopian – namely the development of autonomous vehicles, which require no human intervention even in complex traffic situations.

By 2030, the share of autonomous driving in overall traffic may rise to as much as 40%.

*Shared.* For several years, many big cities have offered car-sharing facilities. While these are currently often run as pilot projects, sharing concepts will become economically viable with the introduction of autonomous vehicles. It will no longer be necessary to search for a shared vehicle in the surrounding area: instead it will be possible to order vehicles to wherever the user happens to be via a convenient “on demand” service.

Professionally managed fleets of shared vehicles will reduce the cost of mobility by a significant amount through more efficient use of expensive mobile assets.

*Connected.* The networking of cars with the outside world is summarised by the concept of the Connected Car. This term actually

represents two concepts at once. On the one hand, it applies to Car2Car and Car2X communication, which is the networking of the car with other cars or with the transport infrastructure (such as traffic lights). On the other hand, the term also covers the networking of vehicle occupants with the outside world. In future, they will be able to communicate, work, surf the internet or access multi-media services during the journey.

*'Yearly' updated.* The range of models will be updated annually to integrate the latest hardware and software developments, and react to changing requirements of shared fleet buyers.

The development topics of electrified, autonomous, connected and shared will lead to a clear increase in the rate of innovation within the automotive industry. Model cycles of five to eight years, which have always been common in this sector, could soon be a thing of the past. Instead, the range of models will be updated annually in order to integrate the latest hardware and software developments. As customers will naturally not want to buy a new vehicle every year due to the high purchase costs, the short innovation cycles will enter the market primarily through regular upgrades of shared vehicles.

If they want to remain successful, both manufacturers and suppliers will have to offer user-oriented innovations. All these trends are likely to become increasingly apparent between 2020 and 2025 – which means that these are decisive years for manufacturers and their suppliers.

## ЛІТЕРАТУРА

1. Саєнко Н.В. Навчальний посібник з англійської мови «English for Engineers» для студентів-бакалаврів технічного ЗВО спеціальності «Галузеве машинобудування». Харків: ХНАДУ, 2020. 158 с. (Електронне видання на CD-ROM)
2. Саєнко Н.В. Science and Technology: навчальний посібник. Харків: ХНАДУ, 2016. 180 с.
3. Paul O'shea. Automotive electronics: What are they, and how do they differ from “normal” electronics? URL: <https://www.powerelectronicsnews.com/automotive-electronics-what-are-they-and-how-do-they-differ-from-normal-electronics/>
4. How automobile is made. URL: <http://www.madehow.com/Volume-1/Automobile.html>.

## ТЕРМІНОЛОГІЧНИЙ СЛОВНИК

ability	здатність
accelerate	розганяти
accessible	доступний
accessories	обслуговувальні механізми
account for	забезпечувати
adjust	приспосовувати
adoption	упровадження
affordable	доступний
airbag	подушка безпеки
airbag	повітряна подушка безпеки
air-breathing combustion engine	повітряно-реактивний двигун
allow	дозволяти
alternating current (AC)	змінний струм
alternative	варіант
alternator	генератор змінного струму
altitude	висота
ambient	зовнішнє середовище
amount	кількість
anti-lock braking system	антиблокувальна гальмівна система
approach	підхід
appropriate	відповідний
approximately	приблизно
arise	виникати
at full capacity	на повну потужність
at will	за бажанням
attempt	спроба
automaker	автовиробник
autonomous	автономний
available	наявний
avoid	уникати
avoidance	уникнення
be bound	повинен
be dependent upon	залежати
be in charge of	відповідати за
be intended	призначатися
beam	промінь

behaviour	поведінка
belt drive	пасова передача
bench seat	багатомісне неподілене сидіння
bidirectional	двоспрямований
biofuel	біопаливо
body	кузов
brake	гальмо
breakthrough	прорив
bring down	знижувати (ціну)
bucket seat	одномісне ковшоподібне сидіння
bumper	бампер
bumpy	вибоїстий, нерівний
by means of	за допомогою
cable	кабель
capability	здатність
capture approval	набути схвалення
carbon emission	вуглецевомісткі викиди
carburetor	карбюратор
carriage	екіпаж, коляска
chain drive	ланцюгова передача
challenge	проблема, складне завдання
charge	заряджати
chassis	шасі, ходова частина
claw type coupling	кулачкова муфта
clutch	зчеплення
collision	зіткнення
combine	поєднувати
combustion	процес горіння
combustion chamber	камера згорання
common	звичайний
complexity	складність
concerning	що стосується
congestion	затор
connector	з'єднувач
consider	розглядати
continuity tester	тестер цілісності ланцюгів
conventional	стандартний
convert	перетворювати

coolant system	система охолодження
coupling	муфта, з'єднання
crucial	ключовий, вирішальний
crude oil	неочищена нафта
cycle	цикл
dashboard	приладова дошка
date from	починатися
DC (direct current)	постійний струм
deal with	мати справу з
decaying	занепад, руйнування
decent	пристойний
decline	спадати
decrease	зменшувати
defroster	склообігрівач
deliver	доправляти
densely populated area	густонаселений район
depletion	виснаження
dial	показчик, циферблат
directional layering	спрямоване розбиття на рівні
discharge	розряджатися
discourage	відбивати бажання
distinction	відмінність
downward	спадний
drive train	приводний механізм
drivetrain	силова передача, трансмісія
drop-out-of-the-sky	той, що падає з неба
due to	через
efficiency	ефективність
effort	зусилля
electric-propulsion system	електрична рухова установка
elevate	піднімати
eliminate	усувати
emerge	виникати
emergency braking	аварійне гальмування
emission	викид
empty	порожній
enable	давати змогу
enclosed	закритий

energy carrier	енергоносії
energy consumption	витрата енергії
energy density	питома енергоємність
energy source	джерело енергії
energy storage	накопичення й зберігання енергії
engine traction	тягове зусилля
equip	обладнати
erratically	з перебоями
exceed	перевищувати
excess	надлишок
exhaust	вихлопний
exhaust gases	вихлопні гази
exist	існувати
expand, expansion	розширювати, розширювання
expel	викидати, видаляти
explode	підривати
external combustion engine	двигун зовнішнього згорання
fabric	тканина
fall by the wayside	опинитися на узбіччі
fan	вентилятор
faulty	несправний
flanged coupling	фланцева муфта
fleet	парк (автомобілів)
flexible	гнучкий
flywheel	маховик
for instance	наприклад
fossil fuel	викопні види палива
four-stroke	чотирикратний
frame	рама, каркас
freight	вантаж
friction	тертя
friction clutch	фрикціон
friction drive	фрикційний привод
fuel cell	паливний елемент
fuel cell stack	батарея паливних елементів
function	функціонувати
fuse	запобіжник
gain importance	набувати більш важливе значення

gain momentum	набирати хід
gasoline	бензин
gear	шестерня
gear differential	диференціал із шестернями
gearing	зубчата передача
glove compartment	бардачок
go mainstream	ставати популярним
goal	мета
grade	рівень землі
gradual	поступовий
grille	решітка (радіатора)
growth	зріст
guarantee	гарантувати
guide way	напрямний паз
handle	управлятися з
harmless	нешкідливий
headlight	фара
heat exchanger	теплообмінник
hood	капот
hybrid	гібридний
hydrogen	водень
hyperloop	гіперпетля
i.e.	тобто (від лат. id est)
ICT (Information and Communication Technologies)	інформаційно-комунікаційні технології
ignite	запалювати
ignition	запалювання
impact	вплив
imply	мати на увазі
improve	поліпшувати
improvement	поліпшення
in case	у разі
in order to	для того щоб
include	містити (в собі)
increase	збільшувати
indeed	безсумнівно
induction	впуск
infancy	початкова стадія розвитку

injector	інжектор
instead of	замість
insulation	ізоляція
intake	впуск
integrate	об'єднувати
intelligent	розумний
interaction	взаємодія
interior	внутрішня частина
internal combustion engine	двигун внутрішнього згорання
internal combustion engine	двигун внутрішнього згорання
intersect	перетинатися
introduce	упроваджувати
lane	смуга дороги
leather	шкіра
lid	кришка
lithium-ion	літій-іонний
lock up	блокувати
low	низький
low-impact	щадний, з низьким рівнем впливу
magnetic levitation	магнітна левітація
majority	більшість
manage the traffic	керувати транспортом
mandatory	обов'язковий
mankind	людство
means of transport	транспортні засоби
measure, measurement	вимірювати, вимірювання, вимір
mechanical drive	механічний привод
medium capacity	середньої місткості
mesh	зачеплення
milestone	віха, ключова подія
mode	засіб
motion	рух
motorcycle	мотоцикл
muscle power	м'язова сила
noise pollution	шумове забруднення

nozzle	форсунка, випускний отвір
obtain	отримувати
onboard	бортовий
operate	функціонувати, працювати
operation mode	робочий режим
option	можливий варіант
oxygen	кисень
oxygen, to oxidize, oxidizer	кисень, окислювати, окисник
particular	окремий
passenger pod	капсула, відсік
passive restraint	пасивний обмежувач
perform research	проводити дослідження
perhaps	можливо
petroleum fuel	нафтове паливо
piston	поршень
plug-in	підключається до електромережі
pneumatic	пневматичний
port	отвір
power density	щільність енергії
power grid	енергетична система
power transmission system	силова трансмісія
pressurized	герметичний, під тиском
prevent	запобігати
previous	попередній
primary energy source	первинний енергоносіє
prime mover	двигун
proliferation	поширення
property	властивість
protect	захищати
provide	забезпечувати
pull in	втягувати
pure	чистий
put up with	мириться з
rail	рейка
range	діапазон, пробіг без дозаправки
range extended	зі збільшеним запасом ходу
rare	рідкісний
recharge	перезаряджати

recuperate	відновлювати
reduce	зменшувати
reduction	скорочення
refuelling station	заправна станція
regenerative braking	рекуперативне гальмування (з поверненням енергії)
replace	замінювати
require	вимагати
reusable	багаторазовий
reverse	зворотний
revolutions per minute	обертів за хвилину
rotate	обертати
route	маршрут
rowing	веслування
runway	злітно-посадкова смуга
safety clutch	запобіжна муфта
sail	вітрило
sealed	герметичний
seat belt	ремінь безпеки
secondary	вторинний
self-driving car	безпілотний автомобіль
self-heating	саморозігрівальний
share the opinion	погоджуватися з думкою
significantly	значно
silent	тихий
similar	подібний
since	оскільки
solution	рішення
solve a problem	вирішувати проблему
space	простір
spark plug	свіча запалювання
split	розпадатися
starter	стартер
steam	пара
steam reforming process	паровий реформінг
steering	рульове керування
steering system	рульове керування
stopping distance	шлях гальмування

storage tank	паливний бак
store	акумуляувати
straddle	охоплювати з обох боків
stream	потік
stroke	хід
sufficiently	досить
supply	постачати
suspend	підвішувати
suspension system	система підвіски
threat	загроза
through the roof	хоч греблю гати
track	колія
traction motor	ходовий двигун
tremendous	величезний
trigger	запускати
trunk	багажник
turbine blade	лопать турбіни
turn off	вимикати
undesired	небажаний
vapor	пара
vaporize	випарювати
vary	змінюватись, варіювати
vehicle	транспортний засіб
vessel	судно
via	через
viable	життєздатний
voltage	напруга
wagon	візок
weight	вага
when it comes to	коли йдеться про
wipers	склоочисник
wires	дроти
working point	робоча точка
worm gear	черв'ячна передача

Навчальне видання

Н. В. САЄНКО

## ENGLISH FOR AUTOMOTIVE ENGINEERS

*Навчальний посібник з англійської мови для студентів  
автомобільних спеціальностей*

Відповідальний за випуск *А. С. Птушка*

Редактор *Л. В. Кузьміна*

Комп'ютерна верстка *Н. А. Купіної*

Дизайн обкладинки *Н.Ю. Нерівні*

План 2023 р. Поз. 1.

Підписано до друку 20.03.2023 р. Формат 60×84 1/16.

Гарнітура Times New Roman Суг.

Ум. друк. арк. 5,6. Обл.-вид. арк. 7,2.

Зам. № 9/23-В. Наклад сайт.

### **ВИДАВНИЦТВО**

**Харківського національного автомобільно-дорожнього університету**

**Видавництво ХНАДУ, 61002, Харків-МСП, вул. Ярослава Мудрого, 25.**

**Тел./факс: (057)700-38-64; 707-37-03,**

**e-mail: rio@khadi.kharkov.ua**

*Свідоцтво Державного комітету інформаційної політики, телебачення та  
радіомовлення України про внесення суб'єкта видавничої справи до Державного реєстру  
видавців, виготівників і розповсюджувачів видавничої продукції,  
серія № ДК №897 від 17.04 2002 р.*